

**Instruction Manual  
for  
Model TC-720  
and  
Model TC-720 OEM  
Thermoelectric Cooler  
Temperature Controller**

**October 17, 2023  
Drawing #5252 Rev. F**



**1590 Keane Drive  
Traverse City, MI 49696 USA  
[www.tetech.com](http://www.tetech.com)**

**Phone: (231) 929-3966  
Fax: (231) 929-4163  
e-mail: [cool@tetech.com](mailto:cool@tetech.com)**

All Materials Copyright © 2020 TE Technology, Inc.

## General Safety Warnings



This manual must be read and followed carefully before installation and operation. All warnings in this Instruction Manual apply to both the TC-720 and TC-720 OEM versions of the controller. Where “TC-720” is referenced, it is used generically and interchangeably for both the TC-720 and the TC-720 OEM versions of the controller, except where otherwise specifically noted.



THE LATEST REVISION OF THIS MANUAL IS AVAILABLE AT [www.tetech.com](http://www.tetech.com). Verify that you are using the latest revision available.



Do not use in an explosive or potentially explosive environment.



The TC-720 is designed specifically for its intended purpose of providing temperature control of TE Technology’s thermoelectric devices only. The temperature controller is intended for light industrial, laboratory, or similar use; it is not intended for household or medical use.



Do not use the TC-720 to control capacitive or inductive loads as this could damage and/or overheat the controller. Examples of capacitive or inductive loads include but are not limited to motors and solenoids.



Do not use if the controller has been damaged.



Only qualified technicians should install this controller.



Do not allow the electrical connections or components on the printed circuit board, including those on the reverse side of the JP3, JP5, JP6 and JP7 connectors, to touch any electrically conductive surfaces.



Do not operate in an environment where the controller could come in contact with condensation, water, metal shavings, dirt or other contaminants, or electrically conductive materials.



Use ESD (Electrostatic Discharge) protection when installing or handling the controller.



Do not touch any of the electrical connections or components of the TC-720 while the controller is energized. Doing so can disrupt the function of the controller.



The printed circuit board underneath JP7 and exposed components on the printed circuit board could exceed 70 °C under normal operation. Use caution! Protect against accidental contact with hot surfaces.



Improper tuning of this temperature controller can lead to overheating of the load (e.g. cooling assembly, heater, etc.) and other related equipment.



Use protection devices to prevent hazardous conditions and/or damage to equipment.



Each power input that is used must be fused separately. Alternately, a power supply with integral over current protection can be used if it is appropriately sized for protecting the controller/TE device.



Thermoelectric devices can develop potentially hazardous temperatures and/or other potentially hazardous conditions. Read and follow the instructions in TE Technology’s Thermoelectric Cooling Assembly (TCA) Instruction manual before using this controller. If using a thermoelectric device from another manufacturer, read and follow all instructions pertaining to that manufacturer’s device before operating the controller. The (TCA) Instruction manual is available for download from TE Technology's website at [www.tetech.com](http://www.tetech.com).



Do not apply solder to the ends of the wires prior to inserting them into the connectors. This will generate excessive heat at the terminal and result in latent failure. Use copper wire only.

For more information regarding protection devices read TE Technology's Thermoelectric Cooling Assembly (TCA) Instruction manual which is available for download from TE Technology's website at [www.tetech.com](http://www.tetech.com). The terms and provisions relating to protection devices as provided in the TCA Instruction manual are hereby incorporated by reference. A copy of the TCA Instruction manual can also be sent via regular mail upon request.

TE Technology, Inc. does not make any warranty, expressed or implied, that the use or operation of the equipment will be functional or effective if the equipment is not installed and used in accordance with this manual.

TE Technology, Inc. shall not be liable, and Purchaser shall defend, hold harmless, and indemnify TE Technology, Inc. from and against, any losses, costs, expenses (including reasonable attorneys' fees), injuries, liabilities or damages of any kind or nature whatsoever, arising out of the use or inability to use this TE Technology, Inc. product, from the omission or failure to use protection devices, or from failure to comply with this manual. This provision is in addition to any other indemnification provisions which are a part of the Purchase Order or contract with Purchaser.

All specifications are subject to change without notice.

## Table of Contents

License Agreement .....	5
FEATURES .....	8
1.0 SETUP .....	15
2.0 DISPLAY AND MENU OPTIONS .....	30
3.0 Controller Tuning .....	43
4.0 Controller Software and USB Communication .....	46
Controller Schematic.....	75
Troubleshooting Controller .....	76
TC-720 Electrical Connections .....	79
TC-720 Mechanical Package Drawing.....	80
TC-720 OEM Mechanical Package Drawing .....	81
APPENDIX A-Thermistors Available for TC-720 .....	82
Appendix B - USB Communications .....	88
Appendix C – Programming Custom Sensor Curves .....	106
Appendix D – Programming Ramp/Soak Routines .....	110
Appendix E – Additional Notes on Fan Control .....	112

## TE TECHNOLOGY, INC. (TE TECH)

### License Agreement

CAREFULLY READ THE FOLLOWING TERMS AND CONDITIONS BEFORE OPENING THIS PACKAGE OR SIGNIFYING YOUR ACCEPTANCE BY CLICKING THE APPROPRIATE DIALOG BOX. OPENING THIS PACKAGE, CLICKING THE APPROPRIATE DIALOG BOX OR USING ANY PART OF THE SOFTWARE SIGNIFIES YOUR ACCEPTANCE OF (1) THESE TERMS AND CONDITIONS FOR THE LICENSED SOFTWARE, AND (2) THE TERMS OF ACCEPTANCE OF TE TECH FOR ANY PRODUCTS PURCHASED FROM TE TECH. IF YOU DO NOT AGREE WITH THEM, PROMPTLY RETURN THE PACKAGE UNOPENED AND UNUSED ALONG WITH ANY OTHER ITEM THAT WAS INCLUDED IN THE SAME PRODUCT NUMBER FOR FULL CREDIT.

You, as the Customer, agree as follows:

#### 1. DEFINITIONS

“Application Software” shall mean those portions of the Licensed Software created by TE TECH.

“Designated Hardware” shall mean the one (1) hardware device, purchased from TE TECH, upon which Customer shall run the Licensed Software.

“Licensed Software” shall mean the Application Software plus any other software supplied by TE TECH pursuant to this Agreement.

“Third Party Software” shall mean software owned or licensed by a third party, including but not limited to operating systems that is embedded within the Licensed Software or otherwise included with any product provided to Customer from TE TECH.

#### 2. LICENSE

2.1 Except as provided in section 2.2 below, you are granted only a personal, non-transferable, nonexclusive license to use the Licensed Software only on the Designated Hardware. You may copy the Licensed Software into machine readable form for backup purposes or to support your use of the Licensed Software on the Designated Hardware. No other copies shall be made unless authorized in writing by TE TECH. You may not (i) reverse engineer, decompile, or disassemble the Licensed Software (except to the extent such foregoing restriction is expressly prohibited by applicable law); (ii) sub-license, lease, or rent the Licensed Software; (iii) distribute in part, modify, or create derivatives of the Licensed Software; (iv) amend, modify, or supplement Licensed Software with any additional code except for the purpose of further configuring the Licensed Software for use with Designated Hardware; or (v) directly or indirectly, export, re-export, download, or ship the Licensed Software in violation of the laws and regulations of the U.S. The Licensed Software, comprising proprietary trade secret information of TE TECH and/or its Licensor’s, shall be held in confidence by Customer and protected from disclosure to third parties. No title to the intellectual property is transferred, you must reproduce and include all applicable copyright notices on any copy. Licensed Software shall not be copied, reproduced, or used for any other purpose outside of operation of the TE TECH hardware, and shall not be used on any other piece of hardware other than the TE TECH hardware with, or for, which it was provided. Notwithstanding the foregoing, in the event that you download the Licensed Software from the internet without purchasing Designated Hardware, the Licensed Software may only be used for evaluation purposes and must be deleted (including all copies) within fifteen (15) days of downloading. You may not use the Licensed Software with any other equipment other than the Designated Hardware without prior written approval from TE TECH. If no operating system software is included in the software provided under this Agreement, you must make provision for any required operating system software licenses. At its option, TE TECH may, upon request, provide the source code for the Licensed Software. The limited warranty provided in section 3 below shall be null and void immediately upon TE TECH providing the source code, or any portion thereof, to you.

2.2 If you are an authorized TE TECH distributor or an Original Equipment Manufacturer who incorporates the Licensed Software into your equipment for sale to an end user, or you use the Licensed Software to create redistributables, you may transfer the Licensed Software to an end user provided that the end user agrees to be bound by the provisions of this Agreement. You shall use your best efforts to enforce your agreement with customers made in accordance with this Section 2.2 and shall promptly report any violation or suspected violation to TE TECH. In the event that your customer violates any portion of this agreement, you agree to defend, hold harmless and indemnify TE TECH from any and all such claims. TE TECH may, at its option, bring suit against your customer to enforce the terms of this agreement, TE TECH’s costs and expenses incurred as a result of such action (including reasonable attorneys’ fees) shall be your responsibility.

2.3 The Licensed Software may include Third Party Software licensed to TE TECH. Customer hereby acknowledges and agrees that any Third Party Software provided by TE TECH to Customer hereunder (a) shall not be modified and shall be used and/or used and redistributed or resold (to the extent permitted under Section 2.2) only embedded within the TE TECH hardware product as provided by TE TECH, (b) shall always contain and only be redistributed (to the extent permitted under Section 2.2) with all proprietary markings present as provided to Customer hereunder and under the same terms and conditions as set forth in this Agreement. All rights and benefits afforded to TE TECH under this Agreement shall apply equally to the owner of the Third Party Software (the “Third Party”) and its licensors with respect to the Third Party Software. The Third Party and its licensors are intended third party beneficiaries of this Agreement, and the provisions of this Agreement relating to the Licensed Software, as the same incorporate the Third Party Software, are made expressly for the benefit of, and are enforceable by, the Third Party and its licensors. The Third Party and its licensors retain ownership of all copies of the Third Party Software. **Unless a pass-through warranty covering the Third Party Software is extended directly to you by the Third Party, all Third Party Software is provided “AS IS” without warranty of any kind, and each Third Party and its licensors disclaim all warranties, either express or implied, including but not limited to the implied warranties of merchantability, title, non-infringement or fitness for a particular purpose with regard to the Third Party Software. The Third Party shall not have any liability for special, indirect, punitive, incidental or consequential damages.**

2.4 EXCEPT AS PROVIDED IN SECTION 2.2 ABOVE, IF YOU TRANSFER POSSESSION OF ANY COPY OF THE LICENSED SOFTWARE TO ANOTHER PARTY WITHOUT WRITTEN CONSENT OF TE TECH, YOUR LICENSE IS AUTOMATICALLY TERMINATED. Any attempt otherwise to sublicense, assign or transfer any of the right, duties or obligations hereunder is void.

2.5 If the Licensed Software or associated documentation is provided to any U.S. Government entity, unit, or agency, the restrictions set forth at section 52.227-19(c) ("Commercial computer software - restricted rights") of the Federal Acquisition Regulations (FARs) shall apply. If the Licensed Software or associated documentation is provided to the U.S. Government, Department of Defense (DOD), or any entity, unit, or agency thereof, the restrictions set forth at section 252.227-7015 ("Technical Data -Commercial Items") of the DOD FAR Supplement (DFARS) shall also apply.

2.6 For rights granted in this Agreement, Customer shall pay to TE TECH the then-current product price (license fee) for each copy of the Licensed Software provided by TE TECH to Customer.

2.7 Customer shall pay all import duties and registration fees and all sales, use and excise taxes (and any other assessments in the nature of taxes however designated) on the Licensed Software or its license to use the Licensed Software, or resulting from this Agreement, exclusive of taxes based on TE TECH's net income.

2.8 Customer acknowledges that the Licensed Software, including, without limitation, TE TECH logos, trademarks and all information contained therein, is proprietary to TE TECH, is valuable, gives a competitive advantage to TE TECH, and could not, without significant expense and difficulty, be obtained or duplicated by others who have not been able to acquire the same through means expressly authorized in this agreement. You agree that, unless you first obtain the prior written consent of TE TECH, or unless required by law, you shall not communicate or disclose, directly or indirectly, to any person or firm, or use at any time, any of the TE TECH's proprietary information, except as provided in this Agreement. The provisions of the section, among certain others, shall survive the termination of this Agreement for whatever reason. The Licensed Software shall be and remain the exclusive property of TE TECH.

### 3. WARRANTY

3.1 Only if Customer has purchased Designated Hardware (the purchase price of which automatically includes the license fee), TE TECH warrants that the Application Software will be in substantial conformance with the specifications in the manual pertaining thereto as of the date of shipment by TE TECH. If, within ninety (90) days of date of shipment, it is shown that the Application Software does not meet this warranty, TE TECH will, at its option, either correct the defect or error in the Application Software, free of charge, or make available to Customer satisfactory substitute software, or, as a last resort, return to Customer all payments made as license fees and terminate the license with respect to the Application Software affected. TE TECH does not warrant that operation of the Application Software will be uninterrupted or error free or that it will meet Customer's needs. All other portions of the Licensed Software are provided "as is" without warranty of any kind.

3.2 TE TECH warrants that the media on which the Application Software is delivered will be free from defects in material or workmanship under normal use and service for a period of ninety (90) days from the date of delivery. If any defects are discovered in the media is discovered and reported by Customer within ninety (90) days after delivery TE TECH shall, at no cost to Customer, upon return of same to TE TECH, replace the media and deliver (electronically) to Customer a new and complete copy of the Licensed Software.

3.3 Any modification to the Licensed Software by the Customer without the express written consent of TE TECH shall void the warranty.

3.4 THE FOREGOING WARRANTIES ARE EXCLUSIVE AND ARE IN LIEU OF ALL OTHER WARRANTIES WITH RESPECT TO THE LICENSED SOFTWARE WHETHER WRITTEN, ORAL, IMPLIED OR STATUTORY. **NO IMPLIED OR STATUTORY WARRANTY OF MERCHANTABILITY OR FITNESS FOR A PARTICULAR PURPOSE SHALL APPLY. NO WARRANTY ARISING FROM COURSE OF PERFORMANCE, COURSE OF DEALING, OR USAGE OF TRADE SHALL APPLY.** NOTWITHSTANDING ANYTHING TO THE CONTRARY HEREIN, UNLESS CUSTOMER HAS PAID TE TECH A SEPARATE LICENSE FEE THEREFOR, TE TECH MAKES NO WARRANTIES AS TO THE LICENSED SOFTWARE, WHICH IS PROVIDED "AS IS" WITHOUT WARRANTY OF ANY KIND, WHETHER EXPRESS OR IMPLIED.

### 4. LIMITATION OF LIABILITY

4.1 IN NO EVENT, WHETHER AS A RESULT OF BREACH OF CONTRACT, BREACH OF WARRANTY, TORT (INCLUDING NEGLIGENCE) OR OTHERWISE, SHALL TE TECH OR ITS SUPPLIERS BE LIABLE FOR ANY SPECIAL, CONSEQUENTIAL, INCIDENTAL OR PENAL DAMAGES INCLUDING, BUT NOT LIMITED TO, LOSS OF PROFIT OR REVENUES, LOSS OF USE OF THE LICENSED SOFTWARE OR ANY PART THEREOF, OR ANY ASSOCIATED EQUIPMENT, DAMAGE TO ASSOCIATED EQUIPMENT, COST OF CAPITAL, COST OF SUBSTITUTE PRODUCTS, FACILITIES, SERVICES OR REPLACEMENT POWER, DOWN TIME COSTS, OR CLAIMS OF CUSTOMER'S CUSTOMERS AND TRANSFEREES FOR SUCH DAMAGES EVEN IF TE TECH HAS BEEN ADVISED OF THE POSSIBILITY OF SUCH DAMAGES.

4.2 EXCEPT AS PROVIDED IN SECTION 5, INDEMNITY, IN NO EVENT, WHETHER AS A RESULT OF BREACH OF CONTRACT OR WARRANTY, TORT (INCLUDING NEGLIGENCE) OR OTHERWISE, SHALL TE TECH'S LIABILITY TO CUSTOMER FOR ANY LOSS OR DAMAGE ARISING OUT OF, OR RESULTING FROM THIS AGREEMENT, OR FROM ITS PERFORMANCE OR BREACH, OR FROM THE LICENSED SOFTWARE OR ANY PART THEREOF, OR FROM ANY SERVICE FURNISHED HEREUNDER, EXCEED THE QUOTED CHARGES FOR THE LICENSED SOFTWARE. ANY SUCH LIABILITY SHALL TERMINATE UPON THE TERMINATION OF THE WARRANTY PERIOD AS SET FORTH IN SECTION 3.

4.3 If TE TECH furnishes Customer with advice or other assistance which concerns Licensed Software or any portion thereof supplied hereunder or any system or equipment on which any such software may be installed and which is not required pursuant to this Agreement the furnishing of such advice or assistance will not subject TE TECH to any liability, whether in contract, warranty, tort (including negligence) or otherwise.

4.4 The products (hardware and software) to be licensed or sold hereunder are not intended for use in any application specifically prohibited in writing by TE TECH, including, without limitation, in any nuclear, chemical or weapons production facility or activity, or other activity where failure of the products could lead directly to death, personal injury or severe physical or environmental damage. If so used, TE TECH disclaims all liability for any damages arising as a result of the hazardous nature of the business in question, including but not limited to nuclear, chemical or environmental damage, injury or contamination, and Customer shall indemnify, hold harmless and defend TE TECH, its officers, directors, employees and agents against all such liability, whether based on contract, warranty, tort (including negligence), or any other legal theory, regardless of whether TE TECH had knowledge of the possibility of such damages.

## **5. INDEMNITY**

5.1 Should the Application Software be held by a court to constitute patent or copyright infringement and its use is enjoined, TE TECH shall, at its expense and option, either procure for Customer the right to continued use, or replace same with a non-infringing product or part, or modify the Application Software so that it becomes non-infringing, or remove the software and refund the license charge pertaining thereto (less reasonable depreciation for any period of use) and any transportation costs separately paid by Customer. The foregoing states the entire liability of TE TECH for patent and copyright infringement by the Licensed Software or any part thereof.

5.2 The indemnity under the preceding paragraph shall not apply to any use of Application Software in conjunction with any other product in a combination not furnished by TE TECH as a part of this transaction. As to any such use in such combination, or any improper or unauthorized use, installation, or operation of the Application Software, TE TECH assumes no liability whatsoever for patent and copyright infringement and Customer will hold TE TECH harmless against any infringement claims arising there from (including, but not limited to, reasonable attorney's fees).

## **6. TERM AND TERMINATION**

6.1 You may terminate the license granted hereunder at any time by destroying the Licensed Software together with all copies thereof and notifying TE TECH in writing that all use of the Licensed Software has ceased and that same has been destroyed.

6.2 TE TECH, upon thirty (30) days' notice, may terminate this Agreement or any license hereunder if Customer fails to perform any obligation or undertaking to be performed by it under this Agreement or if Customer attempts to assign this Agreement without the prior written consent of TE TECH. Within twenty (20) days after any such termination of this Agreement, Customer shall certify in writing to TE TECH that all use of the Licensed Software has ceased, and that same has been returned or destroyed, in accordance with TE TECH's instructions.

6.3 Sections 4, 6 and 7 of this Agreement shall survive any expiration or termination and remain in effect. Termination of this Agreement or any license hereunder shall not relieve Customer of its obligation to pay any and all outstanding charges hereunder nor entitle Customer to any refund of such charges previously paid.

## **7. IMPORT/EXPORT**

7.1 If you intend to import or export (or re-export), directly or indirectly, whether electronically or otherwise, the software products or technical data relating thereto supplied hereunder or any portion thereof, it is your responsibility to assure compliance with U.S. and other applicable governmental import and/or export control laws and, if appropriate, to secure any required licenses or approvals in your own name. You are also responsible for the accuracy and completeness of any information or certification you provide for purposes of import or export control compliance.

## **8. GENERAL**

8.1 This Agreement shall be governed by the laws of the State of Michigan, without regard to its conflict of law provisions. You agree that any civil action or claims which relate to this Agreement or the Licensed Software must be brought and maintained in a court of competent jurisdiction located in Grand Traverse County, Michigan, or, alternatively, the U.S. District court for the Western District of Michigan. You hereby waive venue in any other forum. The provisions of the United Nations Convention on the International Sale of Goods shall not apply to this Agreement.

8.2 Should you have any questions concerning this Agreement, contact TE TECH by writing to: TE TECHNOLOGY, INC., 1590 KEANE DRIVE, TRAVERSE CITY, MI 49696.

8.3 YOU ACKNOWLEDGE THAT YOU HAVE READ THIS AGREEMENT, UNDERSTAND IT AND AGREE TO BE BOUND BY ITS TERMS AND CONDITIONS. YOU FURTHER AGREE THAT IT IS THE COMPLETE AND EXCLUSIVE STATEMENT OF THE AGREEMENT BETWEEN US AND SUPERSEDES ANY PROPOSAL OR PRIOR AGREEMENT, ORAL OR WRITTEN, AND ANY OTHER COMMUNICATIONS BETWEEN US RELATING TO THE SUBJECT MATTER OF THIS AGREEMENT. FURTHER, NO CHANGE OR AMENDMENT TO THIS AGREEMENT SHALL BE EFFECTIVE UNLESS AGREED TO BY WRITTEN INSTRUMENT SIGNED BY A DULY AUTHORIZED REPRESENTATIVE OF TE TECH.

## FEATURES



**TC-720 Temperature Controller**

The TC-720 is a bipolar temperature controller capable of automatically reversing power to Peltier thermoelectric (TE) devices to provide heating or cooling as required to maintain a specific set point temperature. It incorporates a keypad and a liquid-crystal display housed in a die-cast aluminum box. The display allows the user to monitor the sensor temperatures, output level, alarm conditions, and menu settings. The integrated keypad accesses an easy-to-use menu system, allowing the user to adjust all the basic controller parameters such as the set temperature, tuning parameters, and alarm parameters.

The controller can also be connected to a computer via a USB port for advanced programming, data graphing, and data logging. All controller parameters, including the advanced parameters which are not adjustable through the keypad, can be adjusted with the included software and saved to EEPROM. The command set for the controller is also provided which allows the creation of custom software applications using National Instruments LabVIEW, for example.



### PULSE-WIDTH MODULATED POWER OUTPUT WITH SOFT START

The TC-720 regulates the output power to the TE device using a method called pulse-width modulation (PWM). With PWM, power to the TE device is switched quickly on and off at a constant frequency. This creates a square wave pulse of power with a constant time period. The on time, or pulse width, can be varied to create an average output voltage ( $V_{average}$ ) that is required by the TE device to maintain the set temperature.

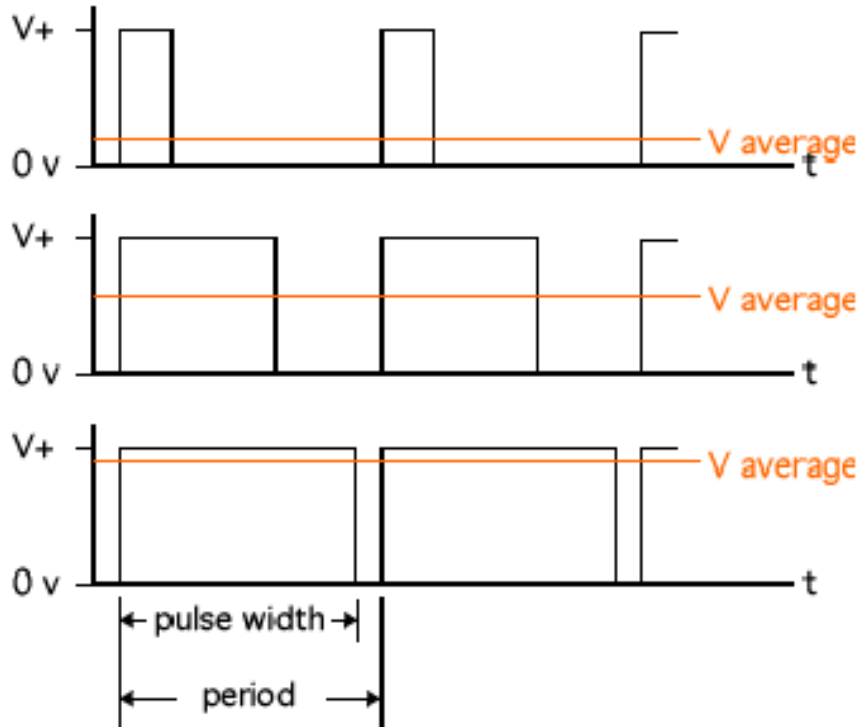

How Pulse-width Modulation Works

The important advantage to PWM control is that it does not cause the extreme temperature excursions that are experienced with a thermostatic control system. This helps to extend the life and reliability of the TE device. At the same time, PWM control does not generate a large amount of waste heat as compared with most linear control systems, so large heat sinks are not required with the PWM temperature controller. The controller features a soft-start function that slowly increases the output when enabled to prevent current surges or spikes at start up.

By choosing the appropriate power supply(s), the controller can control loads from 0 to  $\leq 36$  V DC at up to 20 A via pulse-width modulation with the onboard power transistors arranged in an H-bridge. This enables bipolar control for automatically adjusting the output voltage for heating or cooling.

### LINEAR CONTROL OUTPUT

A potential disadvantage to PWM control is the generation of electromagnetic noise, particularly in high current applications. In such cases, the TC-720 can be configured as part of a linear control system to provide (1) a proportional analog output signal, and (2) a means of reversing the polarity of a drive voltage generated by an external power supply. The analog signal cannot be used for powering TE devices directly, but it can be used with a programmable, linear-output power supply. In this mode the analog output from the TC-720 controls the load-level output voltage of the linear power supply. That linear output voltage can be fed back into the TC-720

where its electronic circuitry (H-bridge) is used to control the polarity of the voltage which is then supplied to the TE device. This provides true bipolar, linear control.

One such power supply that accepts an analog input is the Cotek AE series programmable switching power supplies (<http://www.cotek.com.tw/>). These power supplies accept a 0 to 5 volt input signal which causes the output voltage of the power supply to vary from 0 V to its full-scale voltage. The controller's analog output signal can also be modified to limit its output signal which, in turn, will limit the output voltage from the power supply.

### **RAMP / SOAK PROGRAMMING**

The controller has a built-in ramp and soak capability that provides eight different steps programmable as ramp or hold (soak) functions. Each step can be repeated, or groups of steps can be repeated multiple times. This is useful in creating a multi-step procedure with various temperatures and times for complicated processes or tests.

### **PROGRAMMABLE, ENERGY SAVING, CONTROL MODE FOR COOLING AND HEATING ENCLOSURES**

This control mode provides an energy efficient method for controlling the temperature in an enclosure only when truly needed yet provides greater capability and thermoelectric cooler life than what an ON/OFF or dead band control mode could provide. This mode allows the user to select a three different temperature ranges: (1) a temperature range where no cooling or heating is needed and no output power is sent to the TE Device, (2) a temperature range whereby the controller will proportionally increase cooling power as the temperature increases, and (3) a temperature range whereby the controller will proportionally increase heating power as the temperature decreases.

### **TWO ALARM OUTPUTS**

Two individual alarm outputs, each capable of sinking up to 2 A of current, are provided. These alarms can be triggered based on sensor temperatures.

### **MULTI-SPEED FAN CONTROL OR OTHER LOAD CONTROL**

The Alarm 1 output can be configured to provide PWM speed control of a fan (fan must be specifically designed for speed control) with several customizable settings. Speed control is programmable as a function of the main controller's output power, and the control points are programmable via software. For example, the fan can be run at high speed only when increased cooling capacity is needed, and at a low speed or off when the cooler is operating at a low capacity. The polarity of the output signal can be reversed, so both two wire and three wire PWM controllable fans can be used. The PWM output frequency can be adjusted to make it adaptable to a wide range of fans.

The fan speed control includes a setting to give the fan 100% power for a user-programmable number of seconds when the output is first turned on. This operates the fan at full power to make sure the fan is spinning before reducing power. This is most useful when low output levels are chosen.

### **USER PROGRAMMABLE SENSORS**

In addition to the pre-programmed thermistor curves, a user programmable sensor is available. Through the computer program a custom sensor curve (look-up table) can be created, saved in a separate file on the computer, and uploaded to the controller. An infinite number of sensors can be created for use in the controller as sensor 1 or sensor 2.

### **CONTROL RANGE**

The TC-720 is supplied with one MP-3193 thermistor which provides a control range from -20 °C to +100 °C. For controllers with firmware revision K or later, the control range can be extended to -60 °C to +110 °C using the MP-3176 thermistor. (Controllers with firmware revision J or earlier provide a control range from -40 °C to +70 °C using the MP-3176.) Several other thermistor types are preprogrammed into controller to provide different control ranges such as 0 °C to +150 °C, for example (when using optional thermistors). In addition, a User Programmable Sensor table can also be programmed into the controller allowing it to read temperatures as low as -327.67 °C and/or up to +327.68 °C, subject to sensor type.

### **OVER CURRENT ALARM**

The controller can be set to turn off the output if it exceeds a set current level. The controller will attempt restarting a user-defined finite or an infinite number of times. This is useful for conditions that cause a temporarily high current level, and instead of remaining off when the condition clears the unit will resume normal operation. (NOTE: This is not an analog current limit, the circuit simply senses current levels and turns the output off if an over current condition is detected).

### **STATUS INDICATORS**

The controller has three light emitting diodes (LED's) to indicate an alarm, active computer communications, and controller operation. An alarm is indicated by the orange LED, active computer communication by the blue LED, and controller operating by the green LED.

- The alarm LED is orange and flashes on and off when there is an active alarm.
- The communication LED is blue and lights when the controller is sending or receiving data from a computer.
- The green LED (under the cover of the TC-720 and uncovered in the OEM version) blinks to indicate the controller is on and operating.

The TC-720 is available in an OEM version, model TC-720 OEM. This is a basic version of the controller for Original Equipment Manufacturers (OEM's). It is intended to be used in locations where the controller can be protected by a secondary enclosure and where the display, keypad, and box cover are not needed. The TC-720 OEM controller is the basic control circuit from the TC-720 mounted on an aluminum plate. One MP-3193 thermistor, software, and instruction manual on CD are included with each controller.

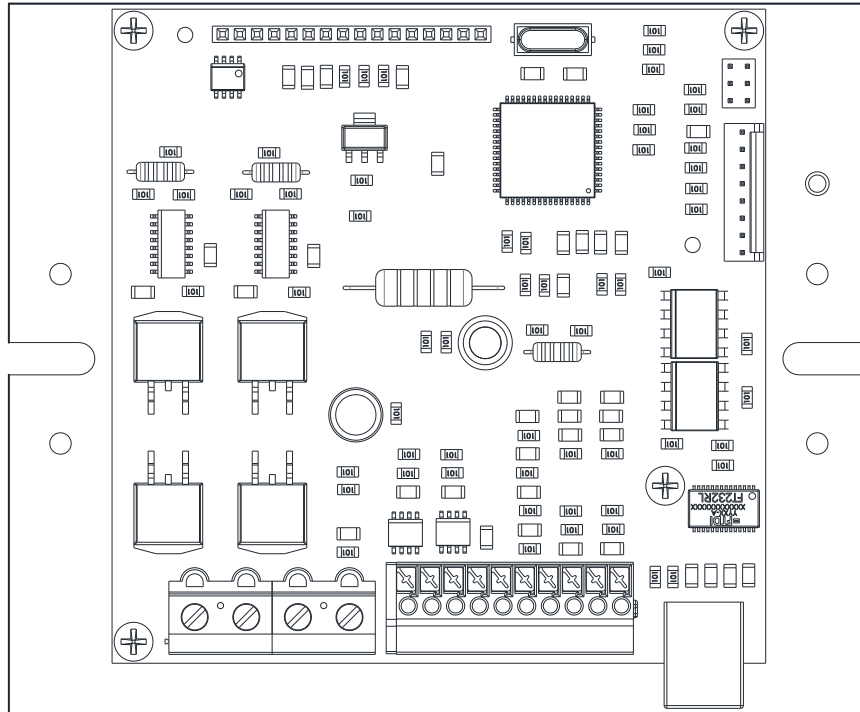

**TC-720 OEM**

The TC-720 OEM uses the same main circuit board found in the TC-720. The connector numbers and wiring are the same for both versions of the controller. The Schematics, Hookup Diagrams, and Wiring Connections presented in this manual are the same for both controllers; however, only the TC-720 version of the controller is depicted for clarity.

## MAIN FEATURES

- Single or dual power supply configurations allow a wide range of output voltages:
  - Single power supply configuration:
    - ≥12 V DC, ≤36.0 V DC input, powering both controller and TE device.
  - Dual power supply configuration:
    - ≥12 V DC, ≤36.0 V DC at 150 mA minimum for controller circuitry
    - ≥0 V DC, ≤36.0 V DC for TE device.
- Pulse-width modulated output: square wave, approximately 337 Hz, with soft start.
- Maximum output current: up to 20 A to thermoelectric device and up to 2.0 A per alarm circuit, 20 A maximum combined output current (Note: controller does not have internal fuse protection).
- Analog signal-level output: provides true linear power control capability when used with a programmable linear power supply.
- Bipolar (heat and cool) PID control.
- Best-case control stability ±0.01 °C (when controlling a cold plate).
- Proportional (P) bandwidth adjustment: 0.5 °C to 100.0 °C.
- Integral gain (I) adjustment: 0.00 to 10.00 repeats per minute.
- Derivative gain (D) adjustment: 0.00 to 10.00 cycles per minute.
- Built in Ramp / Soak with user programmable steps in PID mode, with separate PID parameters allowed for each program step.
- Energy-saving Proportional + Deadband control mode allows the user to program a dead band where no cooling or heating is required, then gradually applies cooling or heating power only as necessary.
- User programmable temperature sensor curve—allows for the use of a variety of thermistors or IC type sensors (LM335, for example).
- Separately selectable temperature sensor types.
- Temperature control ranges:
  1. -20 °C to +100 °C using the MP-3193 thermistor supplied with the controller. Additional control ranges for optional thermistors are:
    - a. -60 °C to +110 °C using a 5k-1 TS-141 curve (***firmware revision J or earlier will provide a control range from -40 °C to +70 °C***).
    - b. -20 °C to +85 °C using the 10k-1 TS-91 curve.
    - c. -15 °C to +80 °C using the 10k-2 TP-53 curve.
    - d. 0 °C to +150 °C using the 50k-1 TS-104 curve.
    - e. +25 °C to +199 °C using the 230k-1 TS-165 curve.(When using one of these control ranges, the thermistor you choose must have the same response that matches the corresponding resistance-versus-temperature curve shown in the appendix of the manual. A thermistor following the 10k-2 TP-53 curve, for example, is not a standard product offered by TE Technology and must be purchased separately from a third party. Other thermistors are available from [www.tetech.com](http://www.tetech.com).)
  2. Used defined sensor table can be used to provide a custom control range for use with different sensor types.
- Optional secondary sensor input for sensing an alarm condition.
- Two available alarm outputs, capable of sinking up to 2 A each, for triggering alarms based on the primary (control) sensor and/or secondary sensor.
- Enable/disable interlock: can be used with thermostats to shut off output power.
- Fan speed control: Alarm 1 output can be configured as a programmable PWM fan control for two-wire or three-wire fans that are specifically designed for speed control.

- Operating temperature range (non-condensing, vertical orientation):  
Minimum: 0 °C  
Maximum: 45 °C
- Back-lit Liquid Crystal Display (LCD).
- USB (Universal Serial Bus) Interface.
- LED indicators for active USB communication, alarm conditions, and controller OK are included on both the TC-720 and TC-720 OEM.
- ESD protection on USB port and inputs, when using provided external earth ground connection.
- Computer programmable via USB communication. (A USB cable is required to interface with the controller, the cabled is included with the TC-720, but is not included with the TC-720 OEM.)
- Software GUI compatible with Windows 10/8 is included. The command set is also included to allow the user to write custom software for the controller.

## OPERATING INSTRUCTIONS

### 1.0 SETUP

- 1.1 Attach the temperature sensor at an appropriate temperature-control location. Locating the sensor at the cold side of the TE device provides better control stability than locating it at the object, liquid, or air that is to be cooled/heated. However, in doing so, there will be a temperature difference between the sensor and the object, liquid, or air that is to be cooled/heated. The temperature set point can be adjusted to compensate for this temperature difference if necessary.

If you are using a secondary temperature sensor, attach it to the appropriate location as well. The secondary sensor, for example, can be used to monitor the hot side of the TE device.

NOTE: When possible, it is recommended that at least 50 mm of the sensor's wire be thermally connected to the surface as shown in the example below. This can be accomplished by taping the sensor wires with aluminum tape, for example. If this is not done, the sensor wires will be at a different temperature than the cold side and they will add or remove heat in the region of the sensor, making the temperature reading potentially **significantly less accurate** and the thermal response time slower.

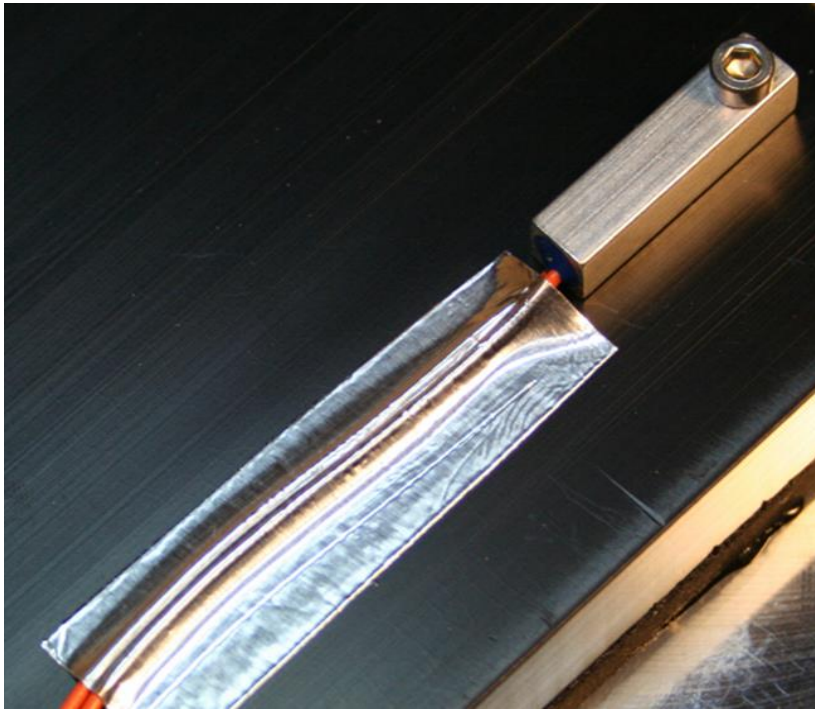

In addition, the sensor itself needs to have a good thermal connection to the temperature control location. Thermal grease, such as the TP-1 from TE Technology, or other suitable thermal interface material should be applied to the interface of the sensor and temperature-control location.

- 1.2 To connect the sensor leads to the controller (as well as other wire connections), you will first need to open up the controller. Remove the four screws from the top of the lid. Lift the lid from the controller, and set it face down next the box.

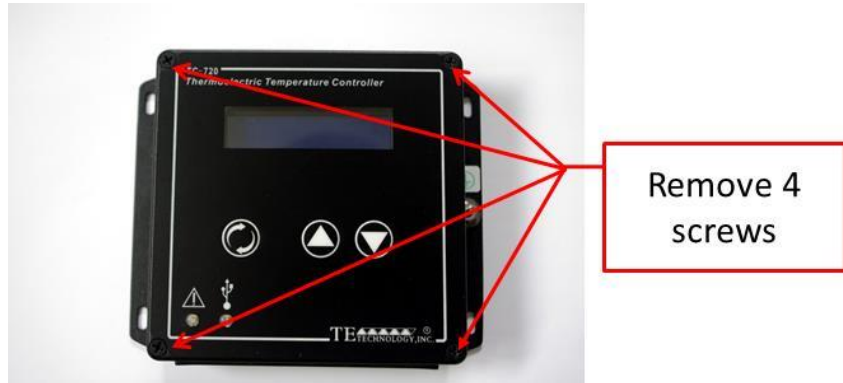

Push the primary sensor wires through the two right-most holes in the rubber face plate located at the front side of the box. The secondary sensor wires would go through the next two holes as applicable. You may need to use a sharp tool to expand the holes before pushing the wire leads through the holes.

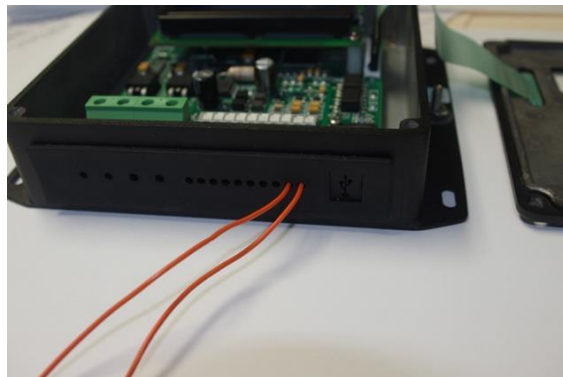

- Connect the primary sensor wire leads to JP2-1 (+) and JP2-2 (-).
- Connect the secondary sensor wire leads (if applicable) to JP2-4 (+) and JP2-3 (-).
- If you are using the MP-3193 or other thermistor, the polarity will not matter. See the controller hookup drawings below for further reference.





If you are using a thermistor for temperature sensing, the wire leads of the thermistor can be lengthened if necessary, without affecting accuracy by any significant amount. However, the use of twisted pair and/or shielded wire may be required to reduce electromagnetic interference.

The TC-720 is pre-programmed to use the 15 k $\Omega$  thermistor curve as the default. The MP-3193 that comes standard with the controller is of this type. Other thermistor styles directly compatible with the controller besides the MP-3193 are available as options. See “*Thermistor Styles for TC-720*” in the appendix for reference or online at [www.tetech.com](http://www.tetech.com). The controller also has numerous other thermistor curves pre-programmed and can be programmed with a user-defined sensor curve. See the temperature vs. resistance data in the appendix for reference.

If you want to use a thermistor that has a different resistance-temperature curve from the pre-programmed thermistor curves, or if you intend to use a different type of sensor altogether, the controller should be programmed accordingly. See “*Programming Custom Sensor Curves*” in the appendix for instructions.

- 1.3 The TC-720 can be used with either one or two separate DC power supplies for bipolar control of one TE device. If the maximum TE device operating voltage is less than 12 V, then two power supplies **must** be used with the controller. If the TE device can use a voltage  $\geq 12$  V but  $\leq 36$  V, then the controller can be used with just one power supply although using two power supplies is permitted as well.

The controller can also be set up to provide linear control output when used with a power supply whose output can be controlled with a 0 to 10 V signal (the maximum output voltage can be reduced as necessary). The power supply can then provide a power output proportional to the signal sent by the controller. This setup may reduce the overall control stability. The voltage signal from the controller is actually obtained by filtering the PWM output, and this introduces a slight delay in the control response. Also, there will be a delay in the response of the power supply since it too must process the correct power output based on the sensed voltage input from the controller.



When using one power supply for powering the controller and the TE device together, the power supply input voltage is passed directly through the controller to the TE device during the “ON” pulse. The power supply must provide a voltage that is  $\geq 12$  V but  $\leq 36$  V and provide sufficient current for the TE device and controller. The controller could be damaged if it is operated outside this voltage range. The TE device must also be capable of operating with the voltage provided by the power supply. Do NOT provide an input voltage that exceeds 36.0 V.



When using two power supplies, the input power supply for the controller itself must be  $\geq 12$  V but  $\leq 36$  V and be capable of providing at least 150 mA of current. The power supply input voltage for the TE device can be  $>0$  V but  $\leq 36$  V and be capable of providing sufficient current.



The total maximum allowable current through the controller is 20 A (combined load and alarm current). The maximum allowable current draw for the TE device must therefore be less than 20 A depending on if and how much current is used by devices connected to the alarm outputs and the controller itself. The 20 A limit applies regardless of whether you are using one power supply or using independent power supplies for the controller and TE devices.



The controller does not have an internal fuse to limit current. Therefore, an external fuse, appropriately sized for protecting the controller/TE device, should be connected between the power supply and the controller to prevent damage to the controller/TE device and to prevent injury to the user should an over-current condition occur. Alternately, a power supply with integral over current protection can be used if it is appropriately sized for protecting the controller/TE device.



When making a cooling system from a single TE module, the maximum operating voltage for that *system* is usually no more than 75% of the rated  $V_{max}$  of the TE module. The 75% rule is based on the TE module being thermally connected to a “good” heat sink; system modeling should be done to verify this rule is applicable though. If multiple TE modules are used in series or series-parallel combination, the  $V_{max}$  of the system will be approximately 75% of the rated  $V_{max}$  of each TE module multiplied by the number of modules in series. Applying a voltage greater than the system maximum will not necessarily damage the controller (unless voltage and/or current limits are exceeded), but the TE device could be damaged by overheating as a result.



Power supply and TE Device wire leads should be kept to a length of one meter or less and of sufficient wire size to reduce electrical losses in the wire and the likelihood of generating unwanted electromagnetic interference. However, see also warnings about wire length under section 1.4.



Use protection devices to prevent hazardous conditions and/or damage to the TE device and other related equipment. Protection devices must operate independently of the temperature controller circuitry. Protection devices should be placed at all points on the load and related equipment where a hazardous condition can be detected. These protection devices should de-energize the TC-720, the TE device, and, as necessary, other related secondary equipment. It is further recommended that such devices require the user to remove and correct the root cause of a fault before allowing the TC-720, the TE device, and related equipment to be re-energized. Protection devices should include, but are not limited to:

- Fuses to defend against electrical overloads
- Over-temperature and/or under-temperature thermostats to prevent against hazardous and/or damaging temperatures,
- Liquid flow meters to prevent against damage due to loss of coolant flow

The TC-720 controller (in conjunction with the standard and optional sensors) can detect under-temperature and over-temperature conditions, and it can be configured to de-energize the load when such a condition is detected. However, hazards and/or risk of loss or damage to the cooling assembly and/or secondary equipment could still occur if the temperature controller and/or sensors were to malfunction. Therefore, independent, redundant protection devices are recommended in addition to the safeguards provided by the temperature controller. For the purposes of this manual the temperature controller and sensors are not considered protection devices.



Protect the USB circuitry from unwanted Electrostatic Discharge (ESD) by either (a) plugging the USB port with the supplied USB dummy plug when not in use (TC-720), or (b) otherwise providing shielding via an enclosure or other external design feature (TC-720 OEM).



Use the supplied rubber face plate gasket to prevent wires from abrading and shorting against metal case (TC-720 only) and to protect the user from inadvertently contacting the circuit board.



**Avoid risk of fire: Do not apply solder to the ends of the wires prior to inserting them into the connector JP7. Do not crimp ferrules onto the ends of the wires before inserting into connector JP7. Use stranded copper wire only.**

When the connector screw is tightened on stranded wire, the wire strands conform to the rectangular metallic aperture within the connector. Each of the individual strands that contact the aperture makes an electrical contact path to the aperture and provides a path to conduct heat away from the connector. With stranded wire there is a lower electrical contact resistance, less heat generated, and more parallel paths for the heat to be removed. With soldered wire ends or ferrules there will be a limited number of contact points between the aperture causing more heat to be generated while yielding fewer paths for it to be removed. In addition, solder can compress over time lowering the tension to the aperture and further increasing contact resistance. Use of soldered wire ends or ferrules will cause latent failure.

ONE POWER SUPPLY OPERATION:



Make sure the power supply is **NOT** energized while making electrical connections to the controller.



The output voltage of the TE Power Supply should not exceed the maximum desired input voltage of the thermoelectric device, or the rated input voltage of the cooling assembly.



If voltage is not between 12 V to 36 V then a two power supply configuration is necessary.

Connect the DC voltage power supply (output voltage:  $\geq 12$  V but  $\leq 36$  V) to the controller as follows:

- a) Connect wire between Positive (+) terminal of the power supply and JP7-4.
- b) Connect wire between Negative (-) terminal of the power supply and JP7-3.
- c) See Section 1.4 for further information on connecting the TE device.

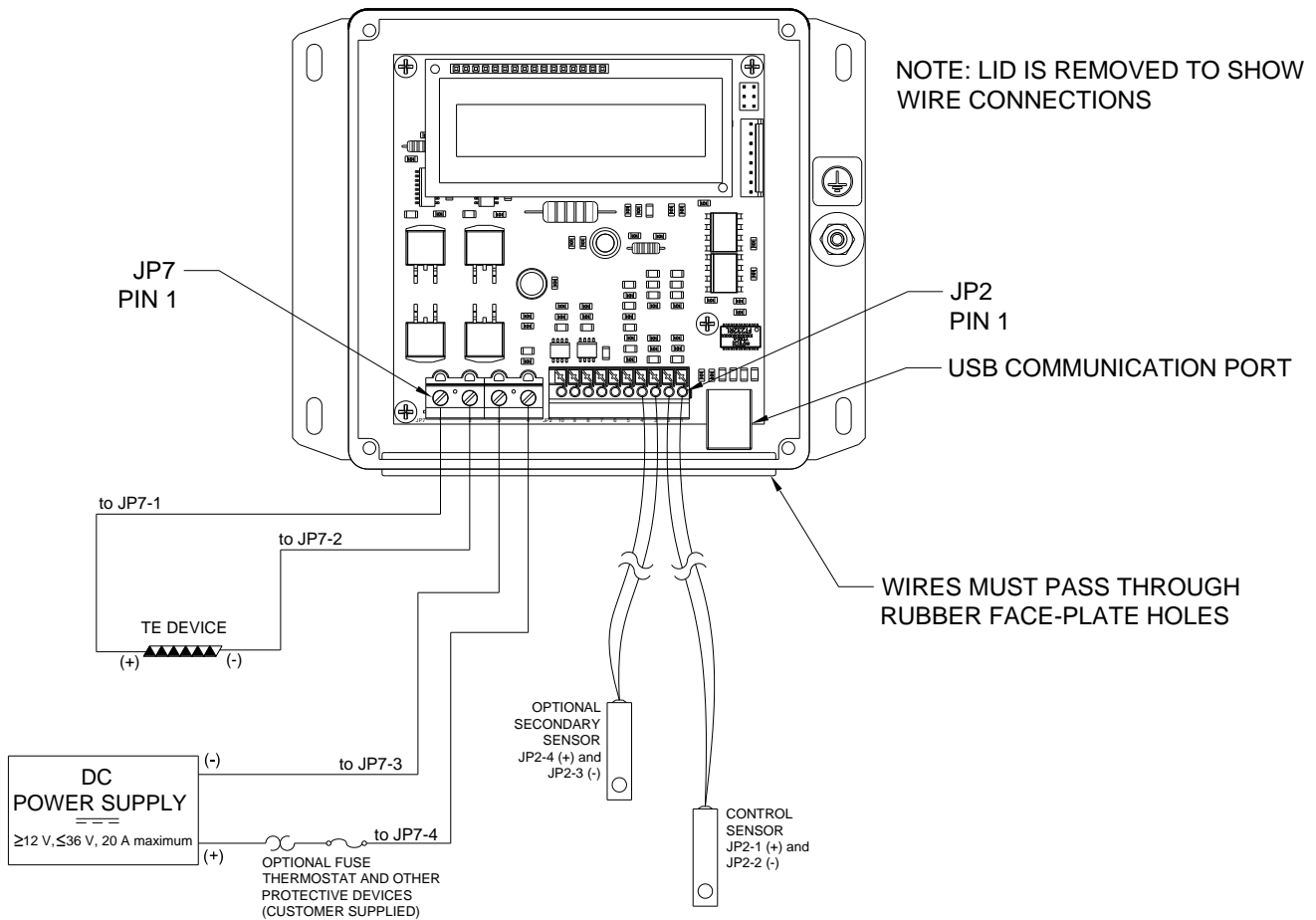

Connections, One Power Supply Operation

### 1.3.1 TWO POWER SUPPLIES OPERATION:



Make sure the power supplies are **NOT** energized while making electrical connections to the controller.



The output voltage of the TE Device Power Supply should not exceed the maximum desired input voltage of the thermoelectric device, or the rated input voltage of the cooling assembly.



If voltage is not between 12 V to 36 V then a two power supply configuration is necessary.

- a) Connect the DC voltage power supply (for powering the controller electronics) to the controller ( $\geq 12$  V and  $\leq 36$  V, 150 mA minimum):
  - i) Connect wire between Positive (+) terminal of the power supply and JP2-9.
  - ii) Connect wire between Negative (-) terminal of the power supply and JP2-7.
- b) Connect the DC voltage power supply (for powering the TE device) to the controller ( $>0$  V but  $\leq 36$  V):
  - i) Connect wire between Positive (+) terminal of the power supply and JP7-4.
  - ii) Connect wire between Negative (-) terminal of the power supply and JP7-3.
- c) See Section 1.4 for further information on connecting the TE device.

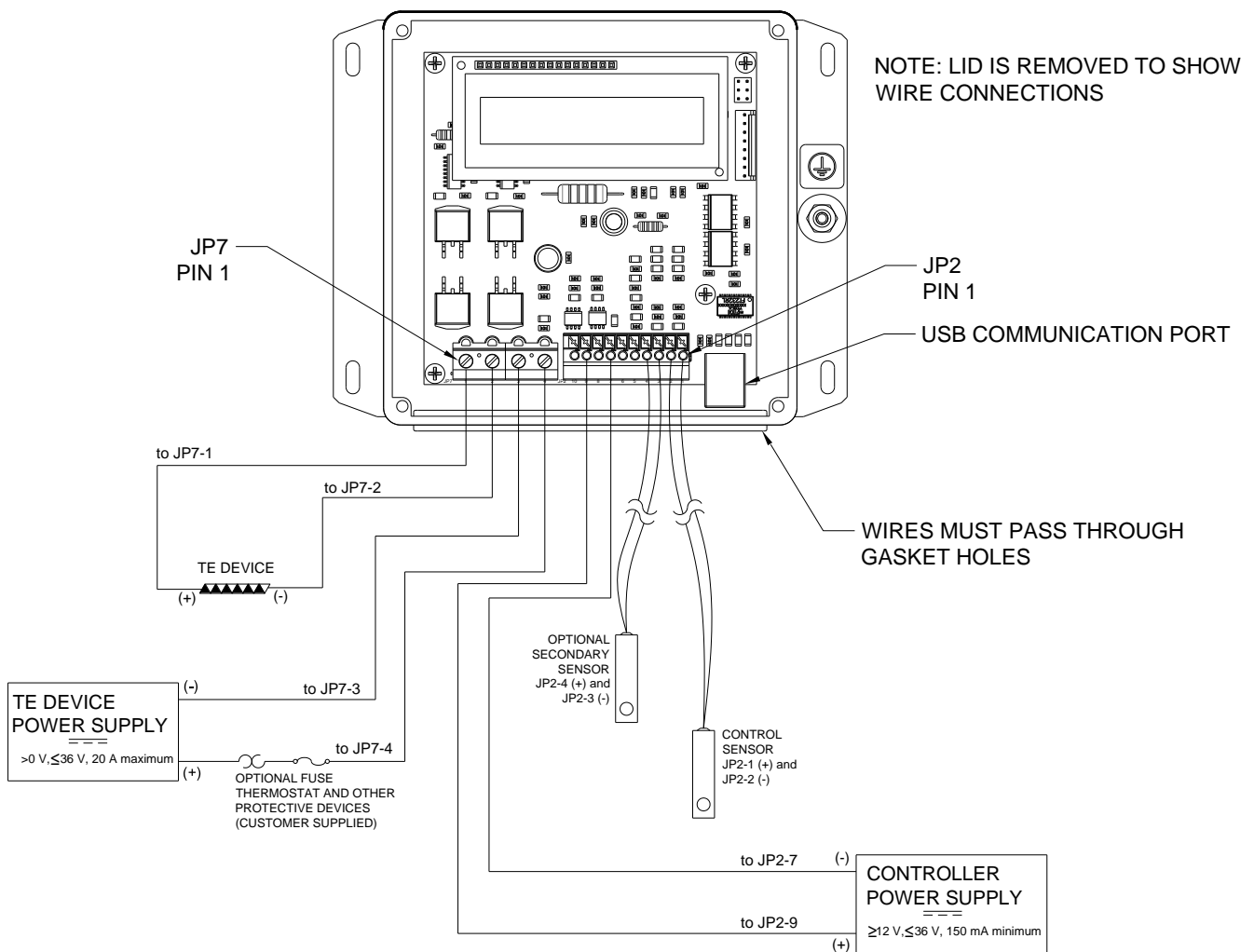

Connections, Two Power Supply Operation

### 1.3.2 LINEAR CONTROL OPERATION (ANALOG OUT CONTROL MODE):



Make sure the power supplies are **NOT** energized while making electrical connections to the controller.



The maximum output voltage of the TE Device Programmable Power Supply should not exceed the maximum desired input voltage of the thermoelectric device, or the rated input voltage of the cooling assembly.



If voltage is not between 12 V to 36 V then a two power supply configuration is necessary.

- a) Connect a constant-voltage DC power supply for powering the controller electronics to the controller ( $\geq 12$  V and  $\leq 36$  V, 150 mA minimum):
  - i) Connect wire between Positive (+) terminal of the power supply and JP2-9.
  - ii) Connect wire between Negative (-) terminal of the power supply and JP2-7.
- b) Connect the remote-control voltage points of the programmable power supply to the analog output signal of the controller; consult the manufacturer's power supply manual for remote control setup:
  - i) Connect wire between Positive (+) remote control terminal and JP2-5.
  - ii) Connect wire between Negative (-) remote control terminal and JP2-7.
  - iii) NOTE: This is a buffered output, however, depending on the power supply remote control input requirements an additional external voltage buffer might be required between the controller and the power supply.
- c) Connect the output terminals of the programmable power supply for powering the TE device to the controller:
  - i) Connect wire between Positive (+) terminal of the power supply and JP7-4.
  - ii) Connect wire between Negative (-) terminal of the power supply and JP7-3.
- d) See Section 1.4 for further information on connecting the TE device, and see SET MODE/ANALOG OUT for a description of how this control mode operates.

NOTE: The controller does not have the internal circuitry to generate a high current analog output voltage from a fixed-voltage supply.

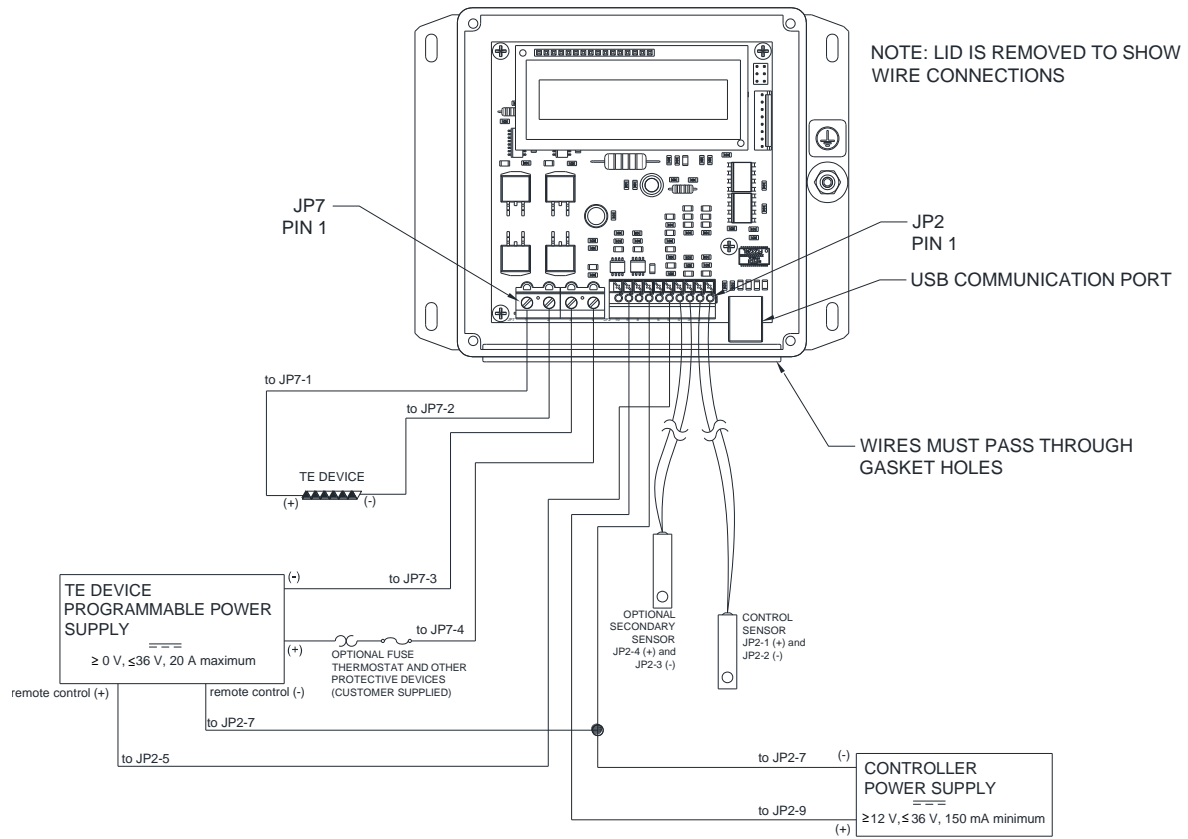

**Connections, Linear Control Operation (Analog Out Control Mode)**

- 1.4 Connect the controller to the TE device as follows (see connection diagrams above for reference):
- Connect wire between Positive (+) terminal of the TE device and JP7-1. Connect wire between Negative (-) terminal of the TE device and JP7-2.
  - If a TE Technology cooler is being used, remove jumpers from the terminal block as described below.



TE Technology's standard thermoelectric cooling assemblies (TCA) usually have at least one fan on the heat sink. The standard configuration has the thermoelectric modules and fan(s) wired to a terminal block with jumpers across the terminals so that the fans and TE modules are connected electrically in parallel. However, this configuration is applicable only when applying power directly from the power supply. When using the TCA with the temperature controller, **two jumpers MUST be removed** so that the controller is controlling power only to the thermoelectric modules. There must be no electrical connection between the fans and the TE modules; fans must be connected directly to the power supply, not to the controller (except for the fan-speed control wire in the case of using a PWM-controlled fan). **The controller will be damaged if this is not followed.** See the TCA manual for further details, but the picture below shows the basic setup.

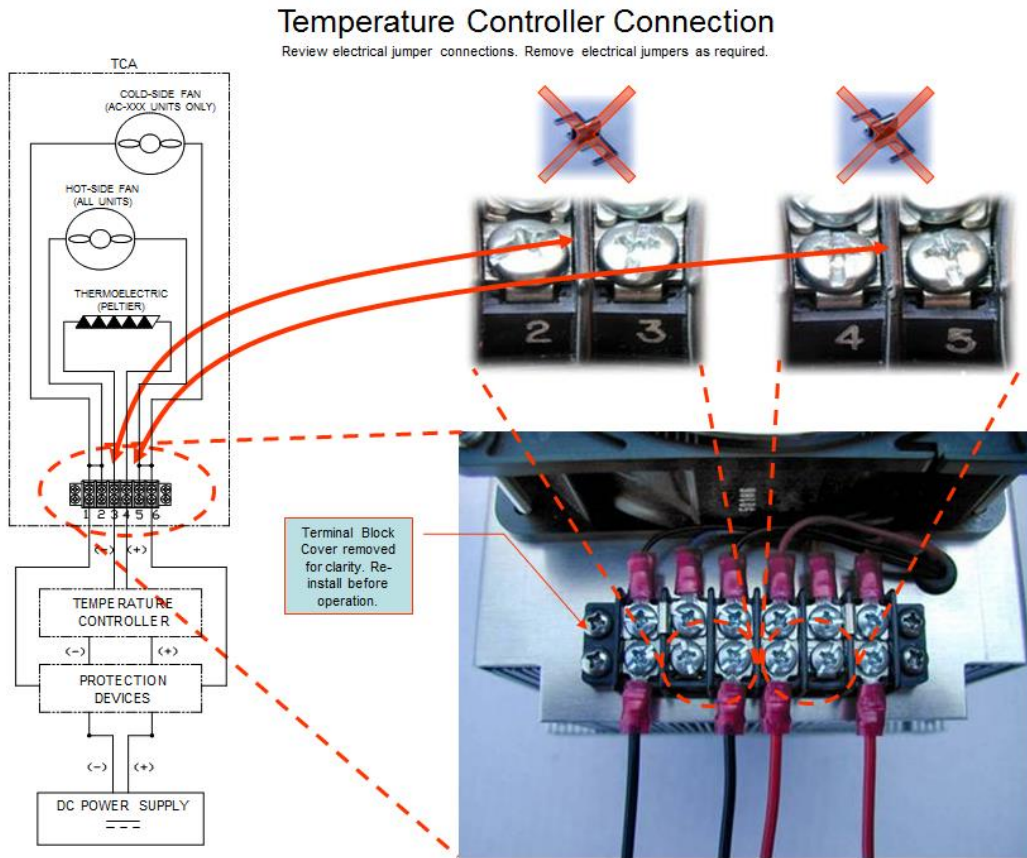





The printed circuit board underneath the JP7 terminal block can reach a normal operating temperature of approximately 90 °C. The controller specifications are based on using wires connecting to JP7 to meet UL 1015 requirements and have a wire size of 2.02 mm<sup>2</sup> effective cross-sectional area, which is comprised of 41 strands of 0.254 mm diameter copper wire. The effective equivalent wire size is 14 AWG. The specifications are further based on a wire length of 410 mm between the power supply and the controller and a wire length of 920 mm between the controller and the TE device. Using wire with a smaller conductor cross section and/or shorter in length might cause abnormally high temperature to be present on the JP7 terminal block and wire. If smaller and/or shorter wire must be used, the amount of current the controller can safely accept might need to be decreased and/or the ambient temperature at which the controller can operate might need to be lowered.



The wires inserted into connector JP7 should have a strip length of 7 mm, be fully inserted into the connector, and the JP7 screw terminals should be tightened with a minimum torque of 0.5 N-m. The allowable cross-sectional area for the conductors is 0.2 — 2.5 mm<sup>2</sup> (AWG 24 — 14).



The wires inserted into connector JP2 should have a strip length of 9-10 mm and be fully inserted into the connector. Do not allow uninsulated wire strands to create electrical shorts between adjacent terminals. The allowable cross-sectional area for the conductors is 0.2 — 1.5 mm<sup>2</sup> (AWG 24 — 16), except 0.16 mm<sup>2</sup> (26 AWG) wire can be used for the sensor inputs.

- 1.5 Connect other applicable devices to the controller:
- Connect optional external alarm LED indicators to JP2-10 (ALARM2) and/or JP2-8 (ALARM1), assuming ALARM1 will not be configured for PWM fan control.
  - Connect optional enable/disable switch between JP2-6 and JP2-7 (or other circuit ground location). The controller will need to be software programmed to enable this feature (described in Section 4). Once programmed, when the switch is closed (electrically shorted), the controller's power output will be enabled. If the switch is open, the output will be disabled. The switch could, for example, be a simple rocker switch or it could be a thermostat. The current between JP2-6 and JP2-7 will be 2 mA when the switch is closed. Use a switch with the appropriate contact ratings, such as gold-plated contacts.

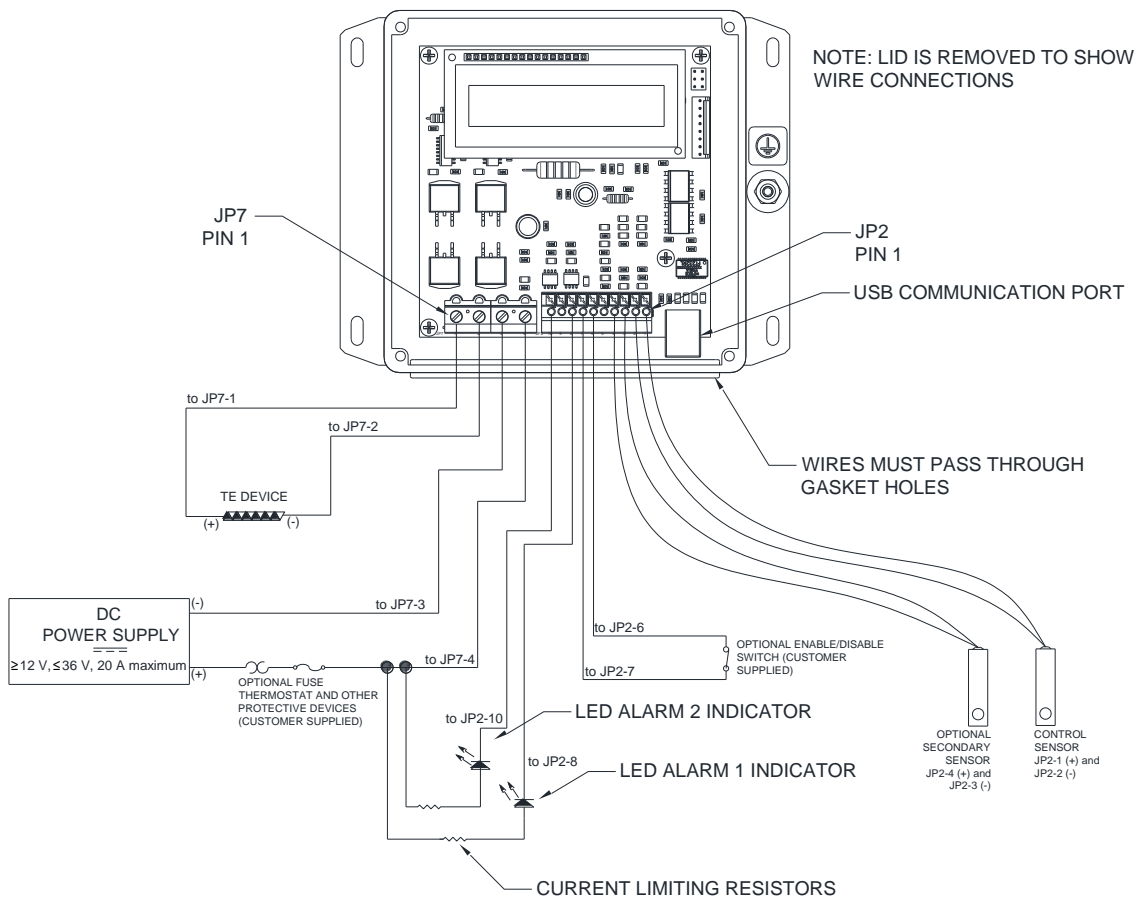

### Connections, Other Applicable Devices

- If you intend to use the controller to speed-control a fan rated for PWM control, connect the PWM speed-control wire as shown below through the rubber face plate, and connect to JP2-8. Be sure to consult the fan manufacturer for further details on the appropriate PWM frequency to use with the fan, minimum duty cycle required for the fan blade to spin, etc.



If the fan only has two or three wires, it is likely not rated for PWM fan-speed control. If the fan is not rated for PWM fan-speed control it should not be used in this configuration. Using PWM fan-speed control with a fan that is not rated for it can damage the fan.

The default configuration for JP2-8 is to serve as ALARM1 output. The controller will need to be software programmed (described in Section 4) for fan speed control rather than serving as ALARM1. ALARM2 may be configured to sense the temperature from the Primary Sensor or the Secondary Sensor as required.

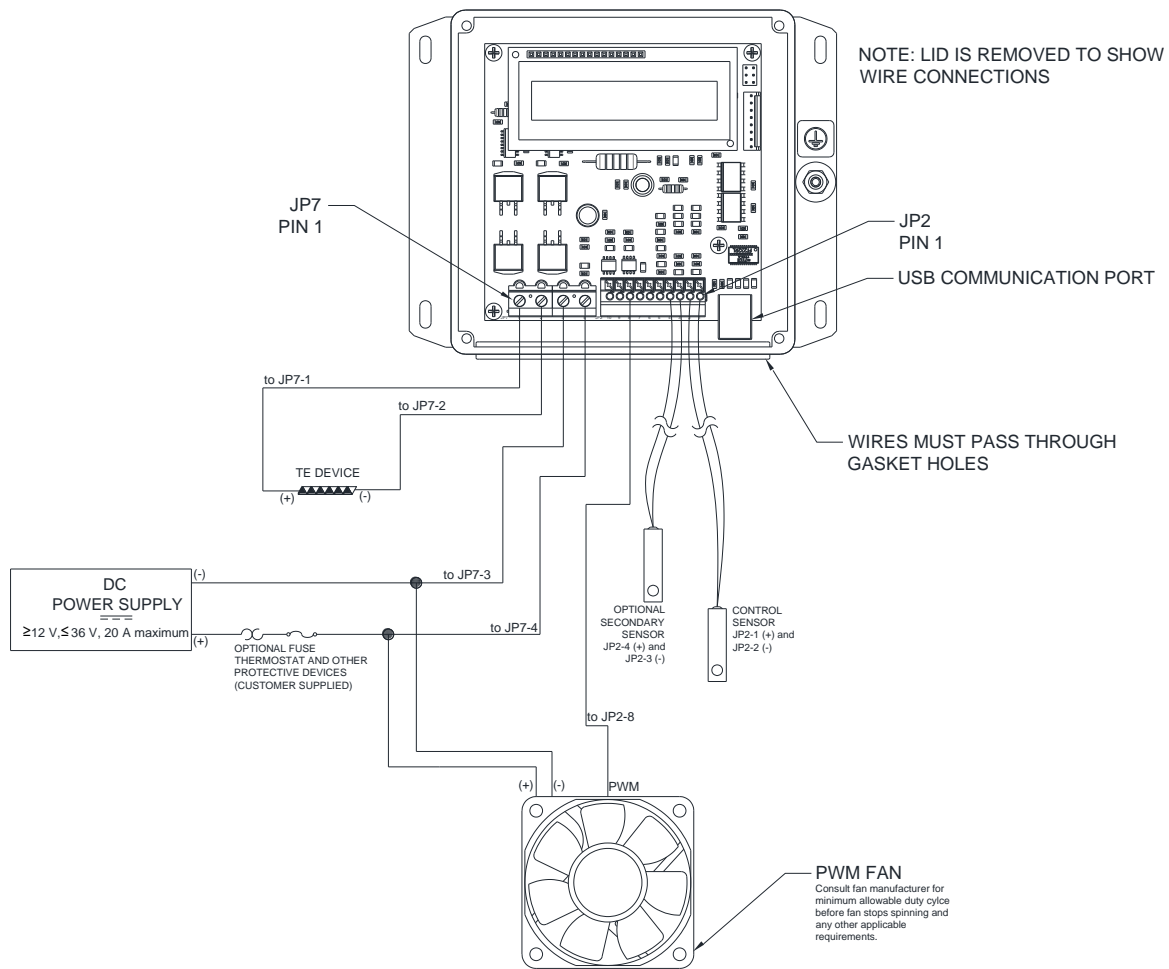

### Connections, Fan Speed Control

*(connections and components may vary depending on the fan being used)*

- d) ALARM1 or ALARM2 outputs could also be configured to power on or off devices such as pumps or fans. Each alarm can manage up to 2 A of current. However, the total current comprised of the current passing through the alarm outputs plus the current passing through the TE device should not be allowed to exceed 20 A.

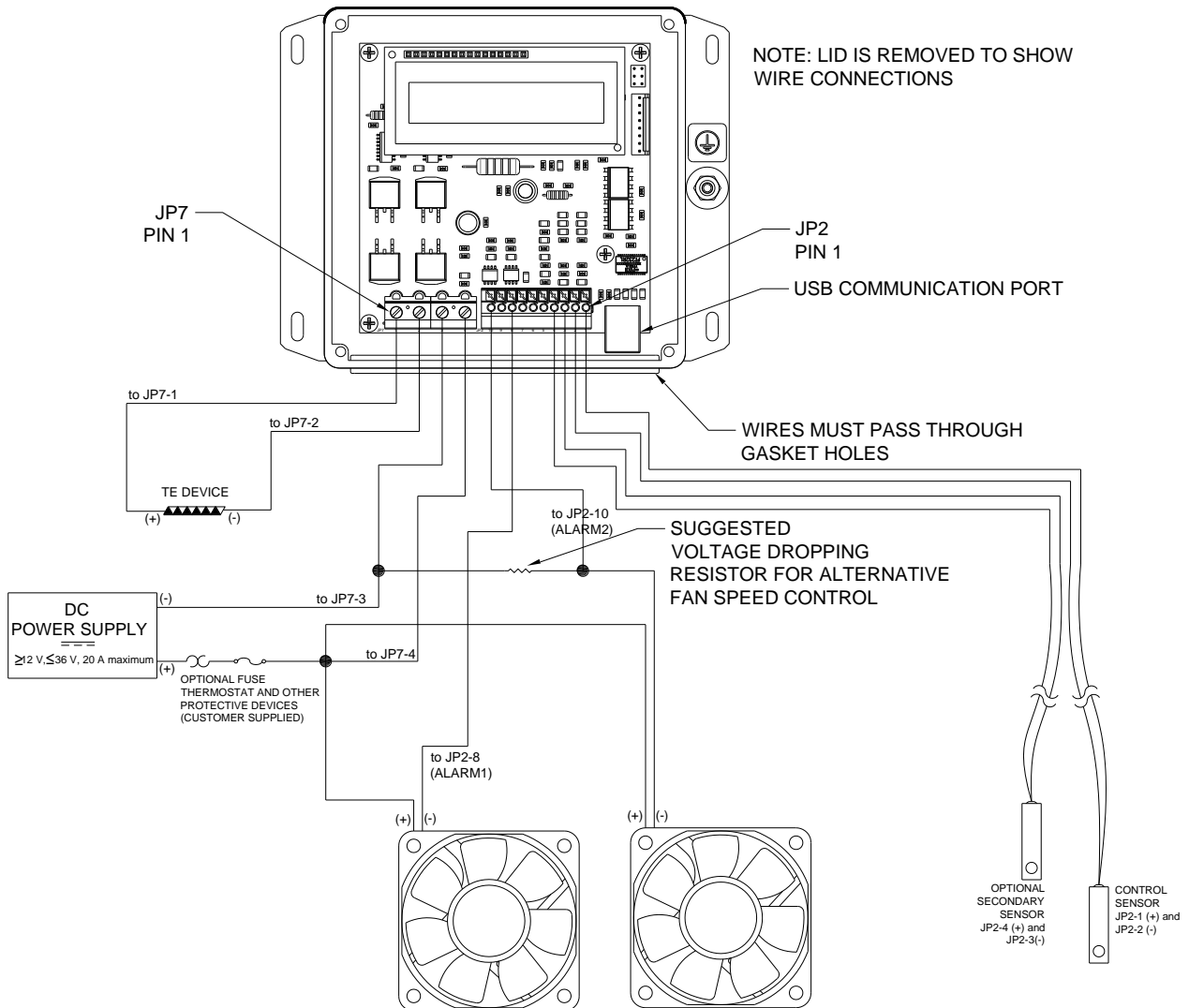

- 1.6 Turn on power supply to the controller and power supply to the TE device if applicable and set controller and tuning parameters as necessary, described in Section 2 and Section 3 or in Section 4 using the software. The factory default is set to have output power to the TE device disabled when the controller is powered on for the first time. However, **DO NOT ENABLE POWER OUTPUT TO THE TE DEVICE UNTIL THE APPROPRIATE CONTROL TEMPERATURE HAS BEEN SET AND THE TE DEVICE HAS BEEN PROPERLY CONFIGURED FOR USE WITH THE CONTROLLER.** Once this is complete, only then should the output power be enabled.

NOTE: ***When not using a thermistor on the secondary sensor input, the ALARM 2 TEMPS must be set to OFF and/or ALARM 2 FUNCTION must be set to KEEP OUTPUT ON.*** The default setting for the controller is to assume that a secondary sensor is attached. If one is not attached, the controller assumes there is a fault condition, and the controller default is set turn off output power in that event. Be sure to configure the controller settings accordingly.



The keypad could reach a normal operating temperature of 70 °C particularly if operating in a warm ambient temperature.



Do not mount the controller to a surface which is exposed to a source of heat, such as from electronics, machinery, or solar radiation.



Do not cover the controller with any object or otherwise restrict natural convection airflow around the controller. Doing so could cause the controller to overheat.



Do not mount the controller to an insulating surface. Doing so could cause the controller to overheat.



Do not operate the controller in such a manner as to cause the surface temperature of the case or internal temperature to exceed 70 °C. Otherwise the controller might be damaged and there might be a risk of fire as a result.



Do not allow the controller to be exposed to water (such as from dripping or leaking water lines or in which the controller is operating at or below the dew point temperature)



Do not allow metallic dust/shavings to enter the controller box.

## **2.0 DISPLAY AND MENU OPTIONS**

Note: this section applies only to the TC-720. Setup, programming, and communications with the TC-720 OEM controller can only be accomplished by using the computer software. Changes made to the controller using the keypad are always stored in the EEPROM regardless of EEPROM WRITE ENABLE setting.

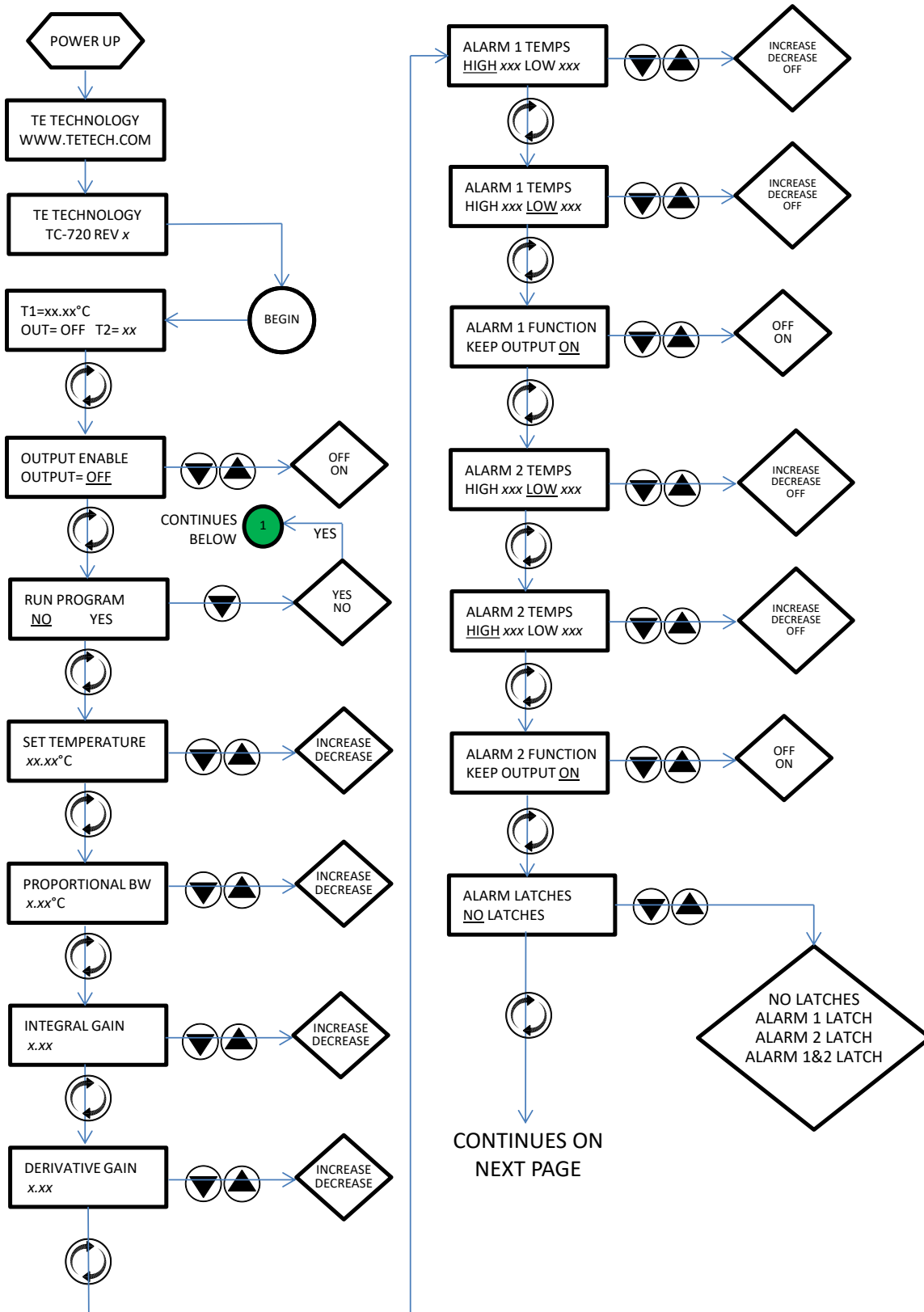

FROM PREVIOUS PAGE

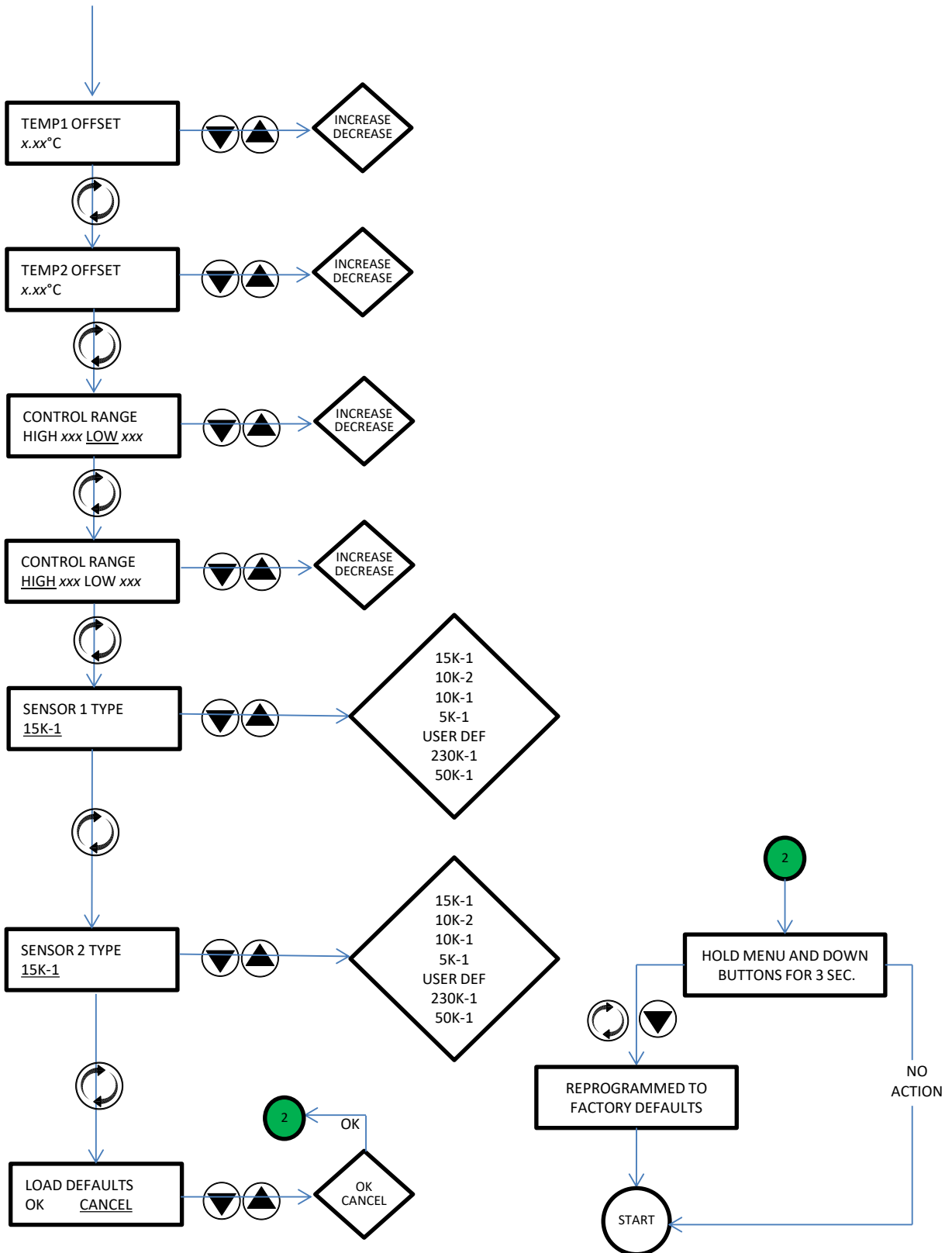



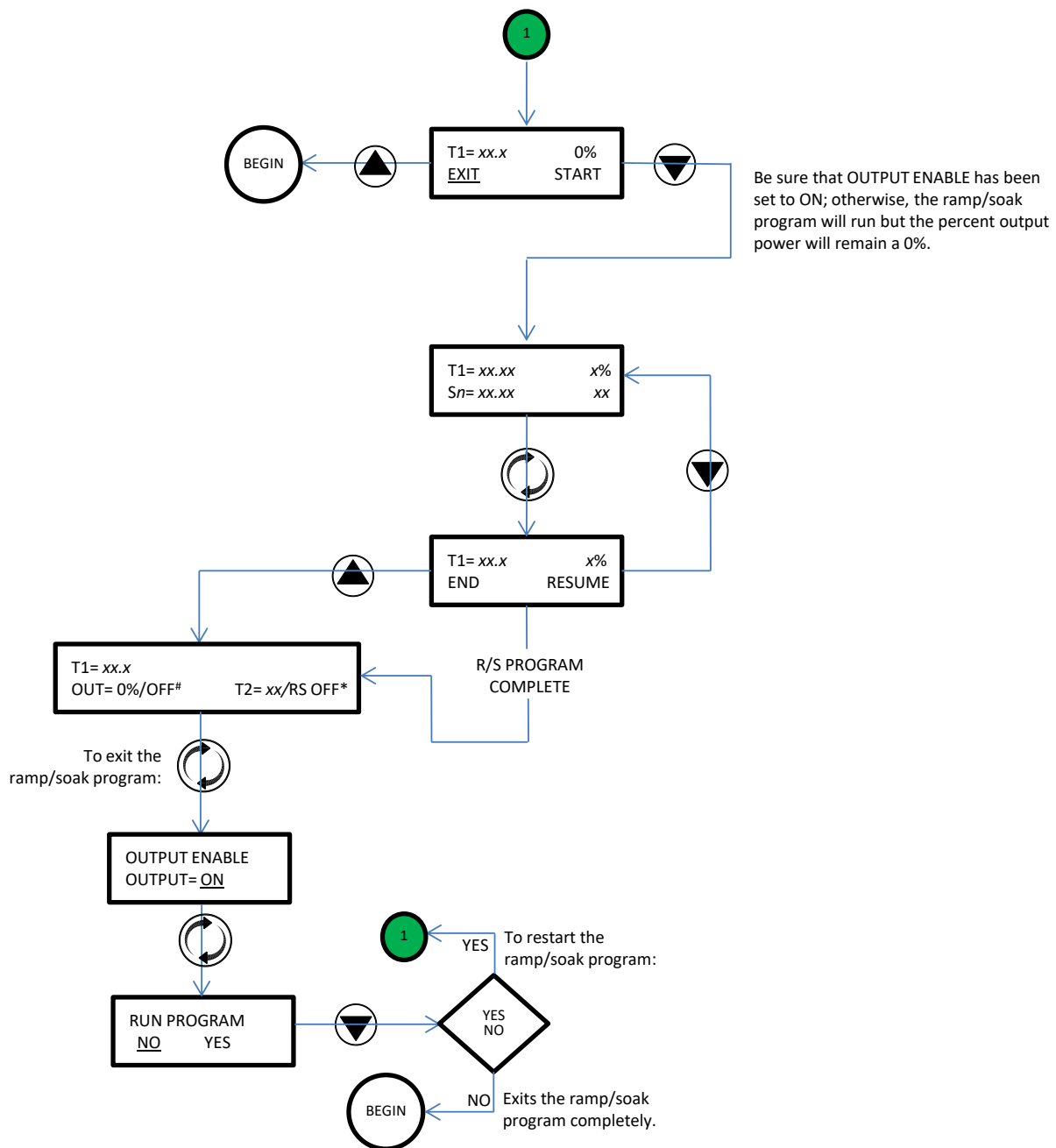

\* Controller alternately displays "T2= xx" and "RS OFF" if a secondary sensor is connected. If a secondary sensor is not connected, "RS OFF" is displayed constantly.

# Controller alternately displays "OUT= OFF" and "OUT= 0%" if ENABLE OUTPUT was set to OFF prior to running the ramp/soak program. If the ENABLE OUTPUT was set to ON prior to running the ramp/soak program, "OUT= 0%" is displayed constantly.

## 2.1 Initialization screen

1. Displays for 1.5 seconds: TE TECHNOLOGY  
www.tetech.com
2. Displays for 1.5 seconds: TE TECHNOLOGY  
TC-720 Rev. \*\*\*\*

## 2.2 Primary screen

T1= ###.## °C  
OUT= ###% [or OUT= OFF] T2= ##

The controller displays information about the following items:

1. The temperature of the control sensor to 0.01 °C resolution (T1)
  2. The output level (% duty cycle) to the thermoelectric device (OUT)
  3. The temperature of the secondary sensor (T2) in °C
- If the control sensor is either an open circuit or a short circuit (indicating that the sensor is not connected or has failed), the controller will display SENSOR 1 ERROR on the top line of the display instead of TEMP= ###.## °C. The output % will also be forced to 0% until the error is resolved.
  - If a secondary sensor is not connected to the controller, T2= ### will not be displayed. (The software can be used to force the display of T2 regardless of whether a sensor is connected. This can only be set through the software; it cannot be set using the keypad).
  - The primary screen will change its format if a ramp/soak program is running, has completed, or has been terminated by the user before it has been completed. See section 2.4.2 for further details.

In addition, if an alarm condition has caused the power output to be turned off, the words ALARM and OUT=0% will flash in alternating sequence in the place of the normal OUT=###% indicator.

***When not using a thermistor on the secondary sensor input, the ALARM 2 TEMPS must be turned OFF and/or ALARM 2 FUNCTION must be set to KEEP OUTPUT ON.***



## 2.3 LED Indicators

The lower left of the TC-720 contains an ALARM LED underneath the  symbol. The LED will be green if there is no alarm condition or orange if there is an alarm condition.

The USB LED underneath the  symbol will be white if there is communication between the controller and a computer if connected by USB.

## 2.4 Parameters Menu

When at the Primary Screen (shown below), depressing the MENU key  allows the user to scroll through and adjust the various controller parameters.

- Press the “MENU” button momentarily to select the parameter to be changed.
- Press the Up/Down arrow keys   to adjust the parameter value.
- If there is more than one value for any given parameter the MENU key will scroll from the first value to the next value and then on to the next parameter.
- Holding the Up/Down arrow keys will cause the value to increment faster.
- The display will return to the primary screen after approximately eight seconds if no keys are depressed.

### 2.4.1 OUTPUT ENABLE

Values: ON, OFF

When ON is selected, power will be sent to the TE device as required to maintain the set temperature, notwithstanding applicable alarm settings or interlock setting (the interlock setting can only be set by using the computer software).

If OFF is selected, the controller will not send output power to the TE device. This setting does not affect Alarm 1 or Alarm 2 outputs. For example, if you have a fan connected to Alarm 1, and there is an alarm condition, the fan would then be powered. The power output to the TE device would remain off regardless of alarm conditions.

**NOTE:** Do not set OUTPUT ENABLE to ON until you have verified that the SET TEMPERATURE is set to a safe operating temperature for the TE device and that appropriate alarm settings and other relevant controller settings have been set.

**NOTE: *The default setting is OFF.***

### 2.4.2 RUN PROGRAM

Values: NO, YES

Description: Leads to the Ramp/Soak program control, see sub flowchart #1.

The Ramp/Soak program must be programmed using the TC-720 software. See the RAMP/SOAK CONFIGURATION under section 4.0 of the manual for further information.

To run the program from the controller keypad:

Be sure to set OUTPUT ENABLE to ON before starting the ramp/soak program.

Assuming a ramp/soak program has been saved to the controller, you can then press the menu button until RUN PROGRAM is displayed, then use the arrow key to select YES. The controller will pause and then begin the ramp/soak program.

### Program Execution (Ramp Soak) Screen

When the controller has entered the Ramp / Soak mode and is executing a program, the following screen information is displayed

T1= ###.##      ###%  
S# = ###.##    C #####

The controller displays information about the following items:

1. The temperature of the control sensor to 0.01 °C resolution (T1)
  2. The output%
  3. The Segment (S) number the controller is currently executing, as well as the current set temperature for that segment
  4. The Count (C) number, or time duration, for that segment
- If a ramp/soak program has completed, the screen will display “PROGRAM COMPLETE” momentarily before returning to the primary screen. If a ramp/soak program has (a) completed or (b) has been terminated by the user before it has been completed, the controller will return to the Primary Screen and alternately display “RS=OFF” and “T2=##” if a secondary sensor is used. If no secondary sensor is used, then “RS=OFF” will be displayed continuously.
  - If a ramp/soak program has (a) completed or (b) has been terminated by the user before it has been completed, the controller will return to the Primary Screen and indicate “OUT= 0%” and “RS=OFF” if the OUTPUT ENABLE was set to ON prior to running the ramp/soak program. If the OUTPUT ENABLE was set to OFF prior to running the ramp/soak program, the controller will alternately display “OUT= 0%” and “OUT= OFF”.

**NOTE:** The controller automatically forces the output% to 0% when a program has (a) completed or (b) has been exited before completion, regardless of the OUTPUT ENABLE setting.

- If the controller has completed a ramp/soak program or the user has terminated the ramp/soak program before it has completed and you want to return the controller to PID control, to the RUN PROGRAM menu and allow the controller to time out with “NO” selected.

To exit out of the ramp/soak program using the controller keypad:

Press the menu key. Then press the arrow key to select EXIT. The controller will pause and then end the program. If you change your mind about ending the program before it has the controller exits the program, you can press the other arrow key to select RESUME in order to continue running the program. If the menu key is accidentally pressed while running the program, RESUME will be highlighted as the default action; after a few seconds, if no other key is pressed, the controller will automatically resume the ramp/soak program.

#### 2.4.3 SET TEMPERATURE

Values: -60.00 °C to +199.00 °C, or as defined by the limits set by CONTROL RANGE

*Default value = 25.00 °C*

Note: For firmware J or earlier, the range of values is limited to -40.00 °C to +199.00 °C, or as defined by the limits set by CONTROL RANGE. If the set temperature in the TC-720 software program is set to less than -40.00°C while using firmware J or earlier, the set temperature will automatically update to a temperature within the -40.00 °C to 199.00 °C temperature range.

Description: SET TEMPERATURE is the control temperature that the controller tries to maintain at the Control Sensor. Note that controller set point should not be set outside the range suitable for (a) the temperature sensor or (b) the device that is being controlled. Consult TE Technology if you need a thermistor that can provide a different control range.

#### 2.4.4 PROPORTIONAL BW

Values: 0.05 °C to 100.00 °C

*Default value = 5.00 °C*

Description: The proportional bandwidth is the temperature span over which the power is proportioned from -100% to +100% power, centered about the temperature set point. That is, the controller output is -100% at the end of the bandwidth range above the set point, it decreases to 0% as it reaches the set point, and then reverses up to +100% as it reaches the bandwidth below the set point.

For example, suppose the controller has a set point of 10.00 °C, the bandwidth is set to 5 °C, and the TE device needs to cool in order to reach this temperature. The controller will provide -100% power (cooling mode) until the sensor temperature reaches 12.5°C. At this point, then controller will then begin to proportionally decrease the output power. The power will be reduced to 0% when the sensor is at 10.0 °C. If the temperature were to decrease further, the power would proportionally increase up to +100% (heating mode) if the sensor is at 7.5°C. (Of course, this example presumes that the INTEGRAL GAIN and DERIVATIVE GAIN are set to zero.)

In practice, the temperature would usually begin to oscillate at some offset from the set point because some amount of power would always be required to achieve some amount of cooling. The offset is corrected by applying INTEGRAL GAIN.

If the bandwidth is set too narrow, the temperature will oscillate around the set point. If the bandwidth is too wide, the controller will be slow to respond or may never reach set point despite INTEGRAL GAIN and/or DERIVATIVE GAIN settings.

**NOTE:** The controller uses a bandwidth adjustment in the control algorithm, which is inversely related to the gain. A smaller bandwidth means a higher gain, and a larger bandwidth means a lower gain.

#### 2.4.5 INTEGRAL GAIN

Values: 0.00 to 10.00 (repeats per minute)

*Default value = 1.00*

*A value 0.00 turns this factor off in the PID algorithm*

Description: With just proportional control, the controller's output would be 0% when the actual temperature reaches the set temperature. However, some non-zero output power is almost always required to reach the set point, so using only proportional control would not allow the controller to maintain a stable set point. Therefore, introducing an integral gain allows for an output power other than 0% when the actual temperature reaches the set temperature.

The integral function applies an additional amount of output power up at a rate determined by multiplying the error, the proportional bandwidth, and the integral gain.

For example, suppose the set temperature is 10.0 °C, the bandwidth is set to 5 °C, and the controller oscillates at around 11.2 °C, corresponding to 48% power with only the PROPORTIONAL BW set.

The error is 1.2 °C, based on the difference between the set point and the temperature the controller settles at (11.2 °C – 10 °C = 1.2 °C). The proportional bandwidth as used in the equation is 100%/2.5 °C = 40%/°C (the 2.5 °C is half the total proportional bandwidth). Lastly, let us assume that the integral gain control is then set to 1 repeat per minute. Thus we have the following:

$$\frac{40\%}{^{\circ}\text{C}} \times 1.2^{\circ}\text{C} \times \frac{1}{\text{minute}} = 48\%/\text{minute}$$

In this example, after one minute of operation the controller calculated that the difference between the desired set temperature and the actual temperature was +1.2 °C. The INTEGRAL GAIN added an additional 48% output per minute. This additional 48% output was added to the existing 48% output to yield 96% output. The integral portion of the output is continuously recalculated at the rate specified by the integral gain setting. The INTEGRAL GAIN always adds or subtracts from the present output power. Of course, the maximum output is limited to 100% and the minimum is limited to 0%.

If the integral control is set too high, the temperature will oscillate. If integral control is set too low, it will take a long time for the temperature to settle to steady state.

#### 2.4.6 DERIVATIVE GAIN

Values: 0.00 to 10.00 (cycles per minute)

*Default value = 0.00*

*A value 0.00 turns this factor off in the PID algorithm*

Description: This senses the rate of change of the temperature and allows the controller to anticipate the power needed to compensate for rapid changes in the system loading. The derivative gain is generally used on very sluggish systems or where very quick response is necessary. It works in a similar way to the integral gain, but it acts upon the change in the error, not the absolute error.

For many thermoelectric systems such as the standard cooling assemblies sold by TE Technology acceptable control can be achieved by turning this function off (0.00).

#### 2.4.7 ALARM 1 TEMPS

Values: -60 to 199 or OFF for HIGH setting; -60 to 199 or OFF for LOW setting

*Default value for HIGH = 60*

*Default value for LOW = -20*

Note: For firmware J or earlier, the range of values are -40 to 199 or OFF for HIGH setting; -40 to 199 or OFF for LOW setting.

Description: This sets the high and low temperatures for signaling an alarm based on the control sensor temperature. Adjustments are in 1 °C increments, and the high setting must be higher than the low setting. If the HIGH setting is increased past 199, OFF is indicated, and no alarm will be signaled based on the control sensor for over-temperature conditions. If the LOW setting is decreased past -60 (-40 for firmware J or earlier), OFF is indicated, and no alarm will be signaled based on the control sensor for under-temperature conditions.

Note: If the controller senses an open circuit or a short circuit on the control sensor, the controller will automatically turn off output power, regardless of the ALARM 1 FUNCTION setting.

#### 2.4.8 ALARM 1 FUNCTION

Values: KEEP OUTPUT ON or TURN OFF OUTPUT

*Default value = TURN OFF OUTPUT*

Description: This setting determines what action will be taken when there is an alarm condition on the control sensor. When KEEP OUTPUT ON is selected, output power to the TE device stays on during the alarm condition, and the alarm 1 signal on JP2-8 is activated. When TURN OFF OUTPUT is selected, output power to the TE device is turned off, and the alarm 1 signal on JP2-8 is activated.



The ALARM 1 and ALARM 2 outputs on JP2-8 AND JP2-10 will momentarily pulse on and off several times in the first second after the controller is turned on. This happens as the microprocessor in the controller configures itself, regardless of any alarm condition.

#### 2.4.9 ALARM 2 TEMPS

Values: -60 to 199 or OFF for HIGH setting; -60 to 199 or OFF for LOW setting

*Default value for HIGH = 60*

*Default value for LOW = -20*

Note: For firmware J or earlier, the range of values are -40 to 199 or OFF for HIGH setting; -40 to 199 or OFF for LOW setting.

Description: This sets the high and low temperatures for signaling an alarm based on the optional, secondary sensor temperature. Adjustments are in 1 °C increments, and the high setting must be higher than the low setting. If the HIGH setting is increased past 199, OFF is indicated, and no alarm will be signaled based on the secondary sensor for over-temperature conditions. If the LOW setting is decreased past -60 (-40 for firmware revision J or earlier), OFF is indicated, and no alarm will be signaled based on the secondary sensor for under-temperature conditions.

Note: If the controller senses an open circuit or a short circuit with respect to the thermistor, the controller will signal an alarm condition (presuming it is not set to OFF). In addition, if the controller senses an open thermistor circuit, T2 will not be displayed in the primary screen.

Using the GUI, the user can configure ALARM 2 to operate from either the input 1 (control) sensor or the input 2 sensor. This selection is not available from the keypad. The factory default is for ALARM 2 to operate from the input 2 sensor.

#### 2.4.10 ALARM 2 FUNCTION

Values: KEEP OUTPUT ON or TURN OUTPUT OFF

*Default value = TURN OUTPUT OFF*

Description: This setting determines what action will be taken when there is an alarm condition on the secondary sensor. When KEEP OUTPUT ON is selected, output power to the TE device stays on during the alarm condition, and the alarm 2 signal on JP2-10 is activated. When TURN OFF OUTPUT is selected, output power to the TE device is turned off, and the alarm 2 signal on JP2-10 is activated.



The ALARM 1 and ALARM 2 outputs on JP2-8 AND JP2-10 will momentarily pulse on and off several times in the first second after the controller is turned on. This happens as the microprocessor in the controller configures itself, regardless of any alarm condition.

#### 2.4.11 ALARM LATCHES

Values: NO LATCHES, ALARMS 1&2 LATCH, ALARM2 LATCH, ALARM1 LATCH

*Default value = NO LATCHES*

Descriptions:

NO LATCHES: If an alarm condition occurs but then clears itself, the alarm signal will automatically turn off and power to the TE device will be restored (assuming ALARM 1 FUNCTION and ALARM 2 FUNCTION are set to TURN OUTPUT OFF).



If the alarm condition is recurring and the ALARM 1 FUNCTION and/or ALARM 2 FUNCTION is set to TURN OUTPUT OFF, the TE device can be damaged by thermal fatigue stress imposed by repeated long-term power cycling.

NOTE: The default deadband for the latch reset is 0 °C. However, the deadband can be reprogrammed using the computer interface to allow for the latch to reset at a specified temperature difference above/below the alarm set point. You can use the software provided with the controller or you can create your own software and use the controller commands as described in “*Serial Communications*” in the appendix.

ALARMS 1&2 LATCH: if an alarm condition occurs from either the control or secondary sensor or both, the controller will continue to signal an alarm until reset, even if the alarm condition is cleared. Power to the controller must be turned off and then on again to turn off the alarm signal. **Alternatively, press and hold the UP ARROW button for three seconds to clear the alarm signal and reset the latches.**

ALARM2 LATCH: if an alarm condition occurs from the secondary sensor, the controller will continue to signal the alarm until reset, even if the alarm condition is cleared. Power to the controller must be turned off and then on again to turn off the alarm. **Alternatively, press and hold the UP ARROW button for three seconds to clear the alarm and reset the latch.**



ALARM1 LATCH: if an alarm condition occurs from the control sensor, the controller will continue to signal the alarm until reset, even if the alarm condition is cleared. Power to the controller must be turned off and then on again to turn off the alarm. **Alternatively, press and hold the UP ARROW button for three seconds to clear the alarm and reset the latch.**

Multi-Speed Fan Control: Alarm 1 can be used for regulating a speed-controlled fan. It can be used to control a separate speed-control input wire/terminal, or to control the input power directly if the peak current draw is 2 A or less. To adapt between two-wire and three-wire control schemes the polarity of this control can be reversed to increase or decrease duty cycle as a function of the main power output %.

The fan control is useful for controlling the hot-side fan of a TE device. One example is having the fan off when the cooler is either off or in heating mode, or it can be set to run at a low speed when the power input to the TE device is at a low level. The speed can be programmed to increase as the main output% increases. Various PWM frequencies are available for the fan which allows the control of many different models of fans.

The fan speed control incorporates an initial period of operation at 100% duty cycle when the output is first turned on, before decreasing to the fan output level as determined by settings. This fan delay is user variable and helps ensure the fan has been given full voltage to start the fan blades spinning before power is decreased. It is useful because fan bearings age, potentially requiring increased start-up voltages.



Speed control should only be used on fans designed to have a controllable speed. Standard two-wire fans not designed for speed control may fail if operated with speed control, creating a hazardous condition. Fans supplied on TE Technology, Inc. products are NOT designed for speed control unless specifically stated.

#### 2.4.12 TEMP 1 OFFSET

Values: -10.0 °C to +10.0 °C

*Default value = 0.0 °C*

Description: Offsets the control sensor value for both the display and control algorithm.

#### 2.4.13 TEMP 2 OFFSET

Values: -10.0 °C to +10.0 °C

*Default value = 0.0 °C*

Description: Offsets the secondary sensor value for both the display and control algorithm.

#### 2.4.14 CONTROL RANGE

For firmware revision K or later: Values: -60 to +199, applies to both HIGH and LOW settings

*Default value for HIGH = 070*

*Default value for LOW = -20*

Note: For firmware revision J or earlier the range of values is -40 to +199.

Description: Sets the maximum and minimum temperatures available in the SET TEMPERATURE menu. This is a safety feature that helps to limit the set point to the safe operating temperature of the system being controlled. Adjustments are in 1 °C increments, and the high setting must be higher than the low setting.

Note: If the CONTROL RANGE is adjusted such that it is no longer inclusive of the SET TEMPERATURE, the controller will continue to control to that SET TEMPERATURE. However, once you scroll to the SET TEMPERATURE menu, the SET TEMPERATURE will automatically reset to be within the CONTROL RANGE, and the output power will adjust accordingly. The SET TEMPERATURE can then only be set within the CONTROL RANGE.

#### 2.4.15 SENSOR 1, SENSOR 2 TYPE

Values: 15K-1, 10K-2, 10K-1, 5K-1, User Defined, 230K-1, or 50K-1

*Default value = 15K-1*

Description:

15K-1 should be selected when using the supplied MP-3193 thermistor or other thermistors with equivalent temperature-resistance curves. See Appendix for further details.

The other thermistors curves should be selected when using thermistors having curves as shown in the Appendix.

A User Defined sensor can be used when the controller is to be used with an IC-type sensor or a non-programmed thermistor, for example. This requires a table of values to be programmed into the controller via computer though. Additional details are available in the software section of the manual below.

Depending on the sensor type being used, the CONTROL RANGE may need to be adjusted as well.



Be sure that you have selected the correct sensor type. Otherwise a dangerous condition could exist because the actual temperature could be higher or lower than the temperature being interpreted by the controller.

#### 2.4.16 LOAD DEFAULTS

Description: Reprograms all settings in the controller to the factory defaults.

Pressing the down key and allowing the menu timer to time out on the YES selection will cause the controller to display another message instructing the user to hold the “menu key” and “up key” for 3 seconds to load the default values. See flow chart 2 for operation.

### 3.0 Controller Tuning

This tuning method follows the Ziegler-Nichols closed-loop tuning principals. Briefly, the controller will first be set to a high proportional bandwidth setting with no integral or derivative function (integral gain and derivative gain = 0). Then, the bandwidth is gradually decreased until the temperature approaches set point and a small, sustained oscillation in temperature is observed. The other tuning parameters are then readjusted based on the time period of the temperature oscillation (natural period) and the proportional bandwidth needed to cause this oscillation.

Remember, the controller uses a bandwidth adjustment in the control algorithm. This is the inverse of gain. A smaller bandwidth means a higher gain, and a larger bandwidth means a lower gain. This should be kept in mind if reviewing online tutorials regarding Ziegler-Nichols closed-loop tuning principals.



Improper tuning of this temperature controller can lead to excessive thermal cycling and/or overheating of the TE device, either of which are known to reduce the lifetime of any TE device. Care should be taken to prevent the temperature of the TE device from going beyond the range specified by the device manufacturer. Care should also be taken so that any thermal cycling of the TE device is a result of changes in the controller's set-point temperature and not instability at a given set point due to improper selection of the tuning variables.

- 3.1 Set the desired control temperature in the SET TEMPERATURE menu.
- 3.2 Set the PROPORTIONAL BW to 20. This is just a starting value; the goal is to determine the proportional bandwidth at which the temperature of the TE device will first begin to oscillate. You might be able to start with a smaller bandwidth, depending on the system, thereby reducing the time it takes to determine the proper bandwidth for good control stability.
- 3.3 Set the INTEGRAL GAIN and DERIVATIVE GAIN to zero.
- 3.4 Decrease the PROPORTIONAL BW incrementally, allowing the TE device to reach steady state at each increment, until the temperature of the TE device begins to steadily oscillate. The system temperature will usually begin to oscillate before it actually reaches the set point temperature; this is normal. Initially, the bandwidth can be decreased in initial increments of 5 °C or perhaps even more. Then, once an initial oscillation is observed, *increase* the bandwidth in small increments until the amplitude of the oscillation is as small as possible but still definitely sinusoidal.  
  
Measure the time period of the oscillation in minutes. This will be used to determine the INTEGRAL GAIN setting below.
- 3.5 Multiply the current PROPORTIONAL BW setting by 2.2 and enter this as the new bandwidth. The system should now maintain a steady state temperature near the set point.
- 3.6 The integral gain is calculated as follows:  $I = 0.54/T$  where I is the integral gain and T is the time period, in minutes, determined in section 3.4 above. Enter this value in the INTEGRAL GAIN setting.

- 3.7 The derivative gain is often difficult to use and might cause more trouble than it is worth. If you are not experienced with process control, you might be better off leaving the DERIVATIVE GAIN set to zero.

If you decide to use derivative gain, the other control parameters should be adjusted first.

- a) Instead of multiplying the initial proportional bandwidth setting by 2.2, multiply it by 1.7, and enter this as the new PROPORTIONAL BW setting.
- b) Calculate the integral gain as follows:  $I = 1.2/T$ , and enter this into the INTEGRAL GAIN setting.
- c) Calculate the derivative gain as follows:  $D = 0.075 \times T$ , and enter this into the DERIVATIVE GAIN setting.

3.8 The control parameters are *approximate* settings. Further adjustments might be needed.

**Tuning Example using proportional bandwidth and integral gain:**

- A. Suppose that smallest PROPORTIONAL BW setting that causes oscillation was determined to be 2.1 °C.
- B. It was then observed that the natural period of this oscillation was 2 minutes.
- C. The PROPORTIONAL BW setting should then be set to 4.6 °C (This is calculated from  $2.1\text{ °C} \times 2.2 = 4.6\text{ °C}$ ).
- D. The INTEGRAL GAIN should be set to 0.27 (This is calculated from  $0.54/(2\text{ minutes}) = 0.27\text{ repeats per minute}$ ).

#### 4.0 Controller Software and USB Communication

The TC-720 and TC-720 OEM can be controlled through the supplied software operating on a computer. The software also provides access to certain features that are not available through the keypad.

In addition, the command set for the controller is provided in the Appendix and can be used to create your own custom software using National Instruments LabVIEW, for example, if the supplied software does not quite meet your requirements. See “*USB Communications*” for descriptions of the command set for the controller.

The TC-720 uses the FTDI FT232RL integrated circuit for communication with the microcontroller. The Windows operating system should automatically install the driver, but if it does not, you will need to do this manually. The latest driver for this is available for downloading at the FTDI Chip website: ([www.ftdichip.com](http://www.ftdichip.com)). The website shows two drivers available: D2XX (DLL) or VCP, but only the virtual communications port, VCP, driver will work properly. **DO NOT INSTALL THE DLL DRIVER.** If the DLL drivers are installed the software will not be able to communicate with the controller.

The software is compatible for use with Microsoft Windows 10.

Software Installation: download the software from <https://tetech.com/product/tc-720/#tab-software> onto the computer and run the setup.exe file with administrator privileges. This process will install the National Instruments LabVIEW runtime engine, the National Instruments VISA runtime engine, the TC-720.exe file, and various support files to your hard drive. (The runtime engines require a minimum of approximately 320 MB of hard-disk space and 256 MB of RAM.) The LabVIEW runtime engine is required since the TC-720.exe is actually an executable version of a LabVIEW .vi file. The computer should ask you to restart. However, you might want to shut down the computer all the way first if you have not connected the controller to the USB port yet. If you have connected it already, then a simple restart should suffice.

Note: The TC-720 install program will verify that you also have Microsoft .NET Framework installed. The install program might indicate that .NET Framework needs to be installed, and this should be allowed. However, Windows usually includes .NET Framework by default but makes the .NET Framework a hidden file, so you might not see it in the list of installed programs.

Connect the controller to the computer with a USB cable. **Do not start the software until after the controller has been connected and the controller has been powered on.** If the software has been started prior to the controller being connected and powered on, you will need to exit the program first, and then restart. **The controller must be powered on prior to starting the software.**

To start the software, navigate to the directory in which you installed the TC-720.exe file (default location is C:\Program Files (x86)\Temperature Controller TC-720\TC-720.exe), then double-click the .exe file. A link is also added to the Windows Start Menu under “Temperature Controller”. Because the temperature controller will be communicating with the computer, you may need to set the computer’s software firewall/antivirus to allow communication. The software will start, and you should see the following screen briefly:

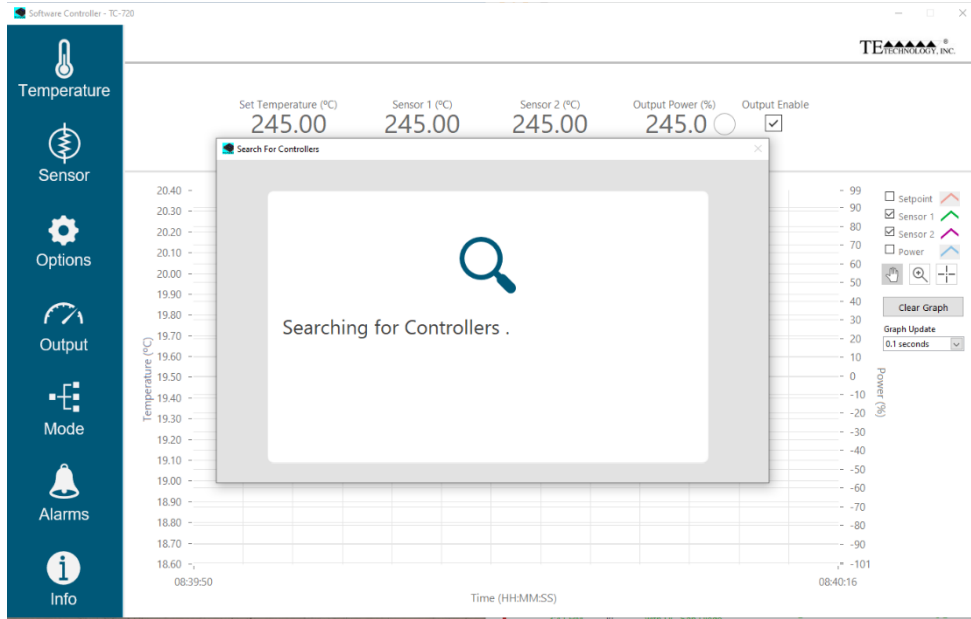

The software is automatically searching for the first available controller. SEARCHING FOR THE CONTROLLER MAY TAKE SOME TIME IF THE COMPUTER HAS MANY USB PORTS TO SCAN THROUGH.

If no controllers are found, a pop-up will occur asking if you want to try searching again or to simply exit:

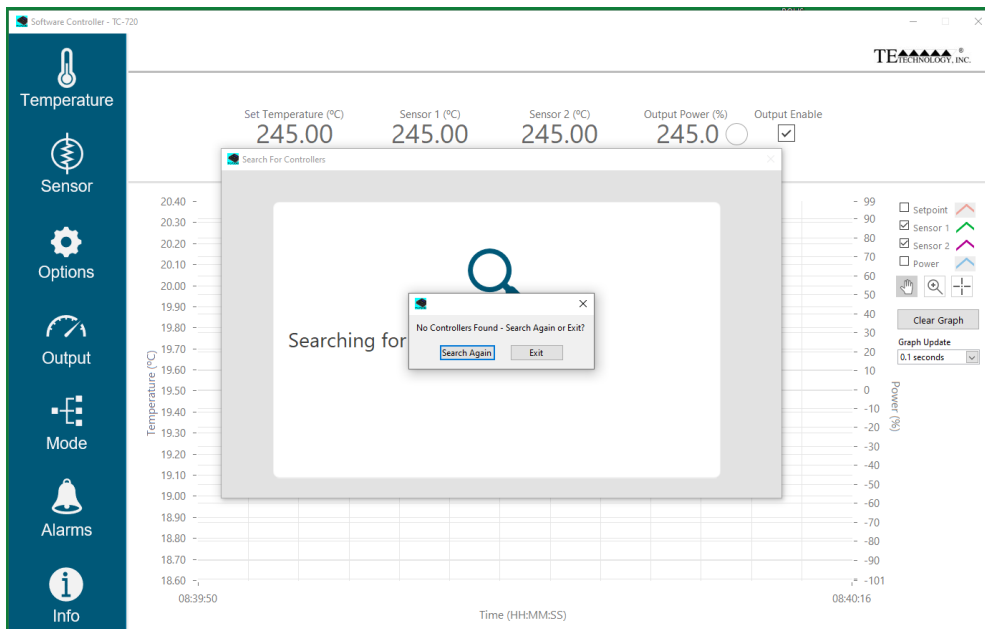

If no controllers are found; shut the software down, and make sure the controller is powered on first prior to restarting.

When the TC-720 software finds the controller, it will connect, read the state of the controller, and begin updating data. The Set Temperature, Sensor 1 (the present value of the control sensor), Sensor 2, (the present value of the secondary sensor), the Output Power %, and the Output Enable checkbox are shown along the top:

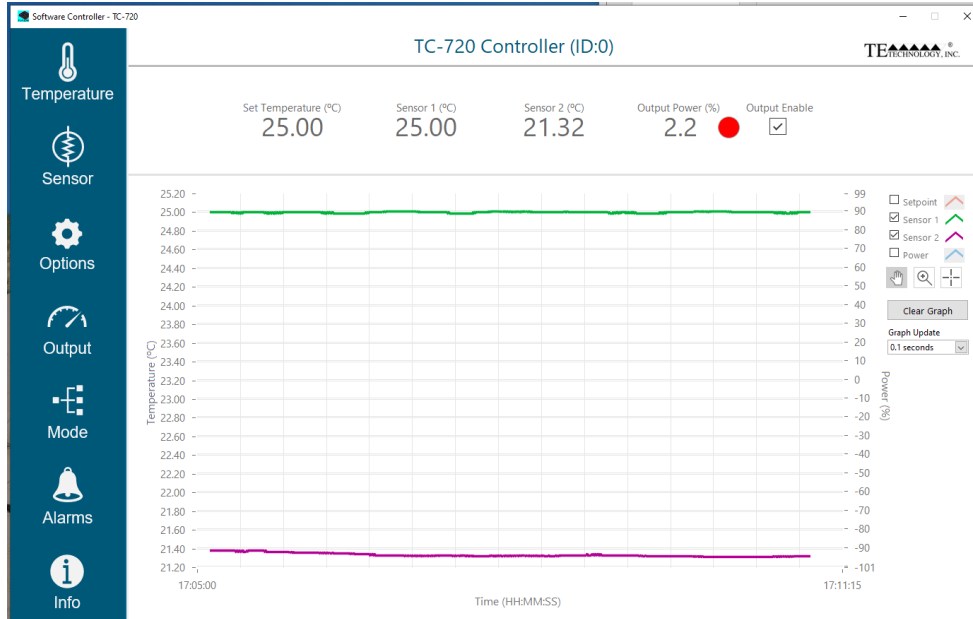

The red dot next to the Output Power, in this case, represents that the controller is in the heating mode. If the controller were in the cooling mode, it would be blue. If the Output Enable box is unchecked, the dot would be white.

#### OUTPUT ENABLE checkbox

The power output from the controller to the TE device can be turned off by unchecking the box or turned on by checking it. Whenever a change is made in the software, the controller is updated in real time. However, it might be beneficial to turn off the output first and then make all software/controller settings before turning on the output. **IF YOU ARE USING THE TC-720 OEM, BE SURE THAT THE OUTPUT ENABLE BOX IS CHECKED PRIOR TO SHUTTING DOWN THE SOFTWARE IF YOU INTEND TO RUN THE CONTROLLER STAND-ALONE FROM THE COMPUTER. OTHERWISE, IF YOU ATTEMPT TO USE THE TC-720 OEM AGAIN WITHOUT THE SOFTWARE, YOU WILL NOT BE ABLE TO TURN THE OUTPUT ON.**

At the upper right next to the graph, you can select the Setpoint, Sensor 1, Sensor 2, and/or Power checkboxes for what will or will not be graphed.

#### CLEAR GRAPH

Clicking this button will clear the previous plot points and start a new plot.

#### GRAPH UPDATE

This provides a drop-down list of various time increments in which the graph is updated with data.



## Graph Viewing



The hand icon allows you to “grab” the graph and move it around for better viewing of an area of interest. The magnifier icon provides several options for zooming in. The crosshair icon just provides a means of preventing inadvertent moving or zooming of the graph

Right-clicking on the graph brings up the following menu options for copying and exporting data and modifying the graph presentation in additional ways.

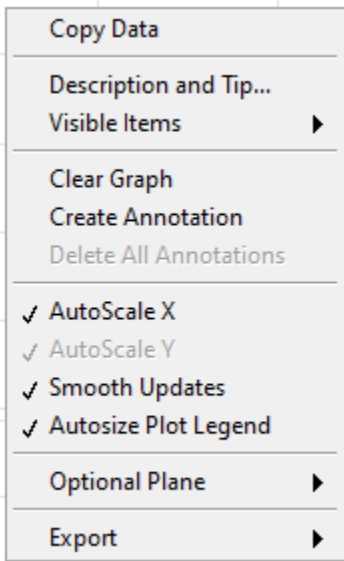

The controller software settings are arranged into seven menu sections on the left of the screen:

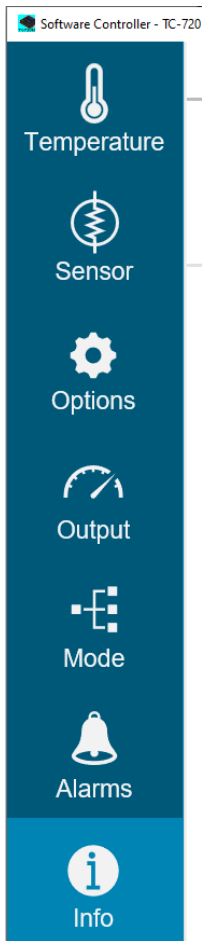

The options for each menu section are revealed by clicking on the menu icon. This opens the options to the right of the menu bar. When you make a change to any of the options, the new parameters are sent to the controller, and then the parameters are read back to the GUI to verify that they received and stored in the controller. You may notice a slight delay between making a change and when the software is next able to respond. This is normal and is due to the processing time it takes to update and verify that the controller has processed the applicable settings. The menu is closed when you click the menu button on the corresponding menu section.

If you make changes to a controller setting via the keypad, the software will automatically detect this change the next time the software polls the controller.



## TEMPERATURE menu

The menu options allow for adjustment of the set temperature, whether a temperature from the secondary thermistor is displayed, and for adjusting the high and low limits of the set temperature. The values can be changed using the up or down menu buttons or by clicking on the number and typing in the desired value and then pressing enter.

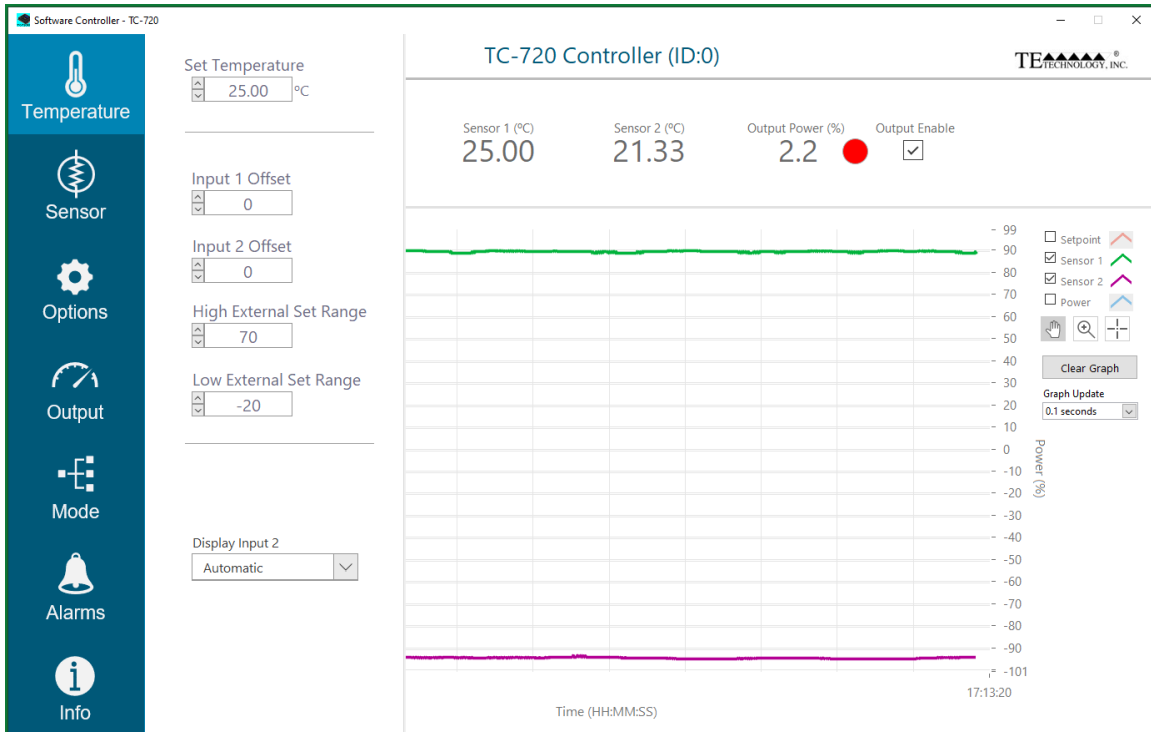

The allowable SET TEMPERATURE is limited to the range defined by the HIGH EXTERNAL SET RANGE and the LOW EXTERNAL SET RANGE. Using an appropriate set range helps to prevent inadvertently using a set temperature that would be inappropriate for the TE device.

The INPUT 1 OFFSET can be used to correct for known sensor errors or differences between the sensed temperature and the actual temperature in the control sensor. The INPUT 2 OFFSET corrects for known differences in the secondary sensor.

NOTE: The SET TEMPERATURE can be set with up to two decimals of precision. However, only whole numbers are permissible for the INPUT 1 OFFSET, INPUT 2 OFFSET, HIGH EXTERNAL SET RANGE and LOW EXTERNAL SET RANGE.

The DISPLAY INPUT 2 can be set to OFF to prevent the controller from showing the secondary sensor temperature on the controller display (LCD), regardless of whether a secondary sensor is attached to the controller or not. When set to AUTOMATIC the controller will only display the temperature if a sensor is attached. Setting it to ON will always display the temperature from the secondary thermistor.

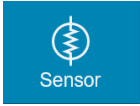

## SENSOR menu

This allows for selecting the type of temperature sensor being used with the controller for the control sensor (SENSOR 1 TYPE) and the secondary sensor (SENSOR 2 TYPE).

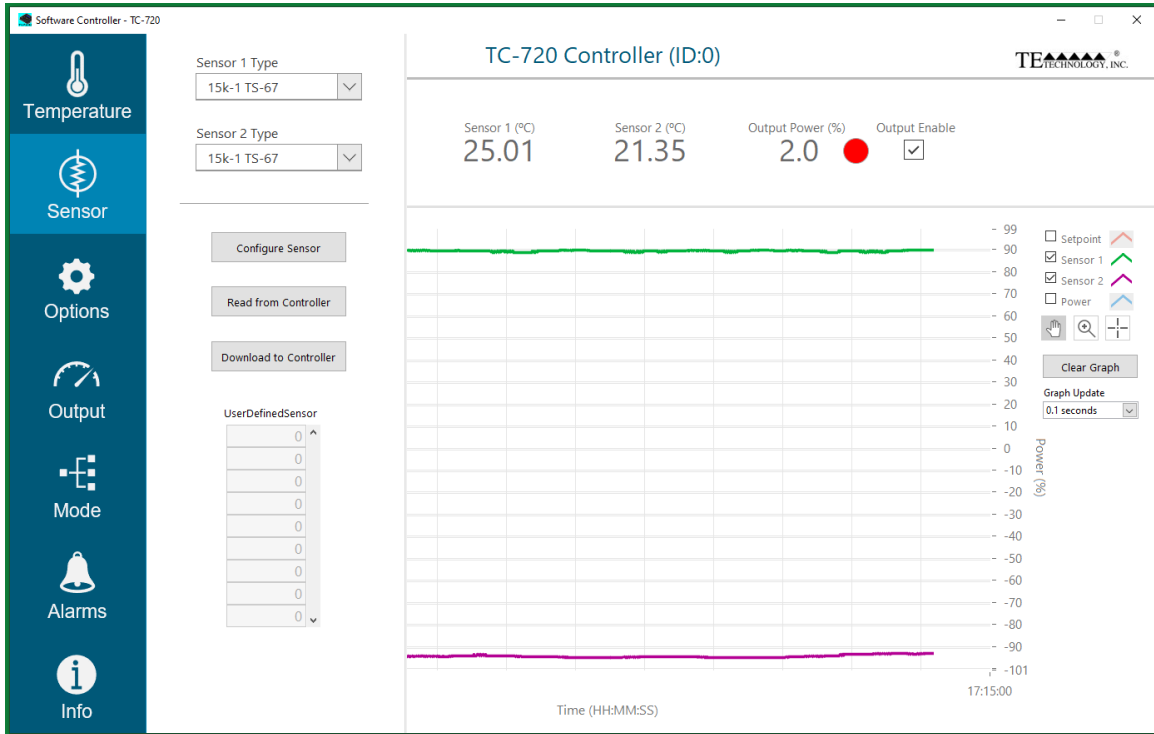

Most of the sensor options correspond to various negative-temperature-coefficient thermistors that TE Technology offers. The temperature-resistance tables for the various sensors are provided in the appendix for reference. Additional information on the thermistors is available online at [www.tetech.com](http://www.tetech.com).

15k-1 TS-67 is the default selection. Using this sensor type provides a control range of -20 °C to +100 °C. The **MP-3193** is the standard thermistor provided with the TC-720 and has a temperature-resistance curve corresponding to the 15k-1 TS-67 type. The MP-2444, MP-2996, and MP-2542 optional thermistors are also of this type.

5k-1 TS-141 provides a control range of -60 °C to +110 °C when using firmware revision K or later. The MP-3176 is of this type. (**Note:** The 5k-1 TS-141 provides a control range of -40 °C to +70 °C when using firmware revision J or earlier.)

10k-1 TS-91 provides a control range from -20 °C to +85 °C.

10k-2 TP-53 provides a control range of -15 °C to +80 °C.

While TE Technology does not offer standard 10 kΩ thermistors at the present time, these two sensors correspond to common 10 kΩ thermistors that are offered by other vendors.

50k-1 TS-104 provides a control range from 0 °C to +150 °C. The MP-3022 is of this type.

230k-1 TS-165 provides a control range from +25 °C to +199 °C. TE Technology does not offer standard thermistors of this type at the present time.

Depending on the sensor being used, the HIGH EXTERNAL SET RANGE and LOW EXTERNAL SET RANGE (see TEMPERATURE menu) may need further adjustment.



Be sure that you have selected the correct sensor type. A dangerous condition could exist because the actual temperature could be higher or lower than the temperature being interpreted by the controller.



The 5k-1 TS-141 sensor resolution will be reduced from 0.01 to 0.02 from -47 °C to -53 °C, and from 0.02 to 0.03 from -53 °C to -60 °C. From 107 °C to 110 °C the resolution will also be reduced from 0.01 to 0.02.

### User Defined

If you are using a thermistor that doesn't match any of the pre-defined curves, or if you want to use an IC-type sensor (such as an LM-335), then the SENSOR 1 TYPE (and/or SENSOR 2 TYPE) should be set to USER DEFINED.

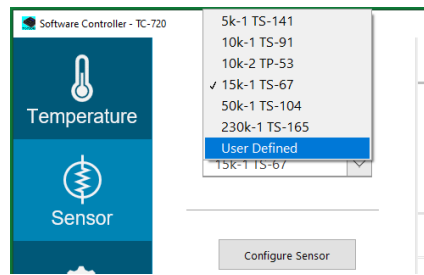

You will need to then create an array of data that is saved in a .csv file. The array consists of 129 array locations that map a voltage, ranging from 0 to 5 Vdc as measured at the sensor terminals, to their corresponding temperatures. Location 0 corresponds to 0 Vdc and location 128 corresponds to 5 Vdc. The maximum temperature range that can be used is from +327.68 °C to -327.68 °C. The controller will interpolate the temperature when the reading is between two values in the table.

**NOTE:** The controller will sense open circuit and short circuit sensor conditions, so using sensor control ranges very close to 5V and 0V should be avoided. The main output will be turned off as a safety precaution if there is an open circuit or short circuit sensor condition detected.

When the range will not fill the 0 to 5 volt region completely, the unused locations in the array can be filled with the previous/last valid value.

*Please see Appendix C for detailed information on creating the custom sensor curve.*

Once you have that .csv file created, click the CONFIGURE SENSOR button, and a pop-up the screen will appear, as shown below:

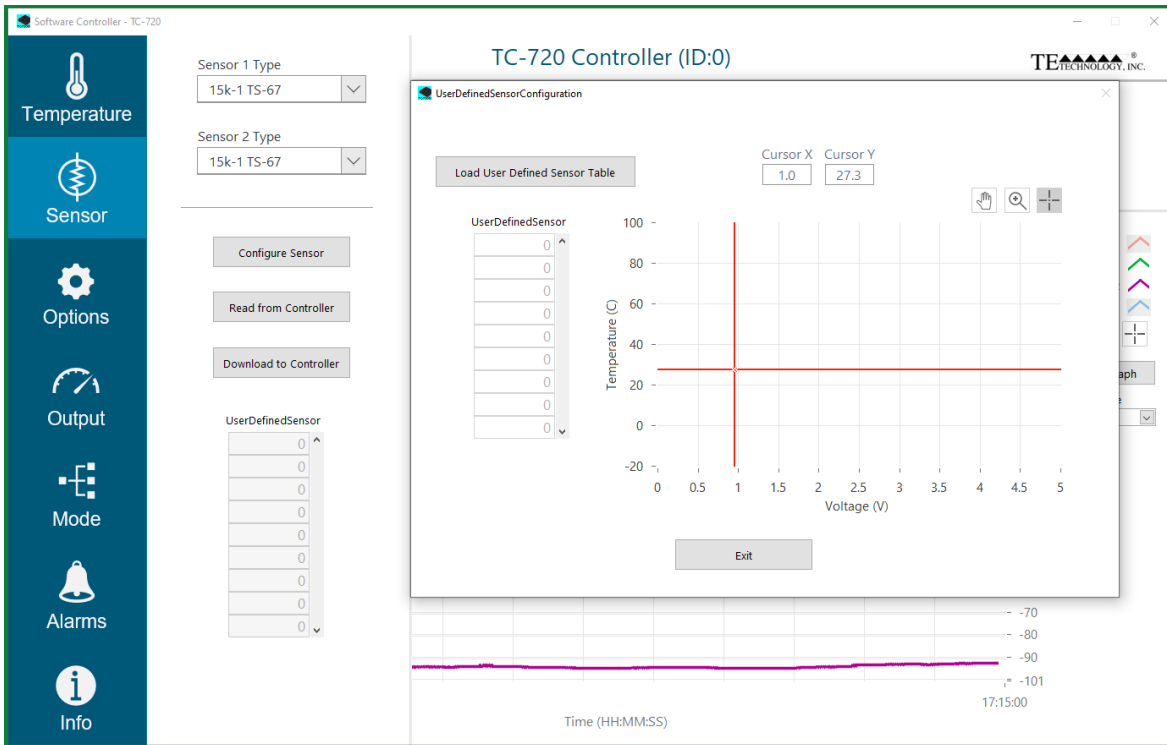

The LOAD USER DEFINED SENSOR TABLE button will open the file manager where you can then select the pre-configured .csv file that contains the temperature data. This will populate the User Defined Sensor Table and plot out the temperature versus sensor voltage so you can graphically see any data entry errors.

Click the EXIT button. Then click the DOWNLOAD TO CONTROLLER button to load the sensor profile into the controller. Clicking the READ FROM CONTROLLER button will query the controller and report back what user defined sensor table is stored in the controller.



## OPTIONS menu

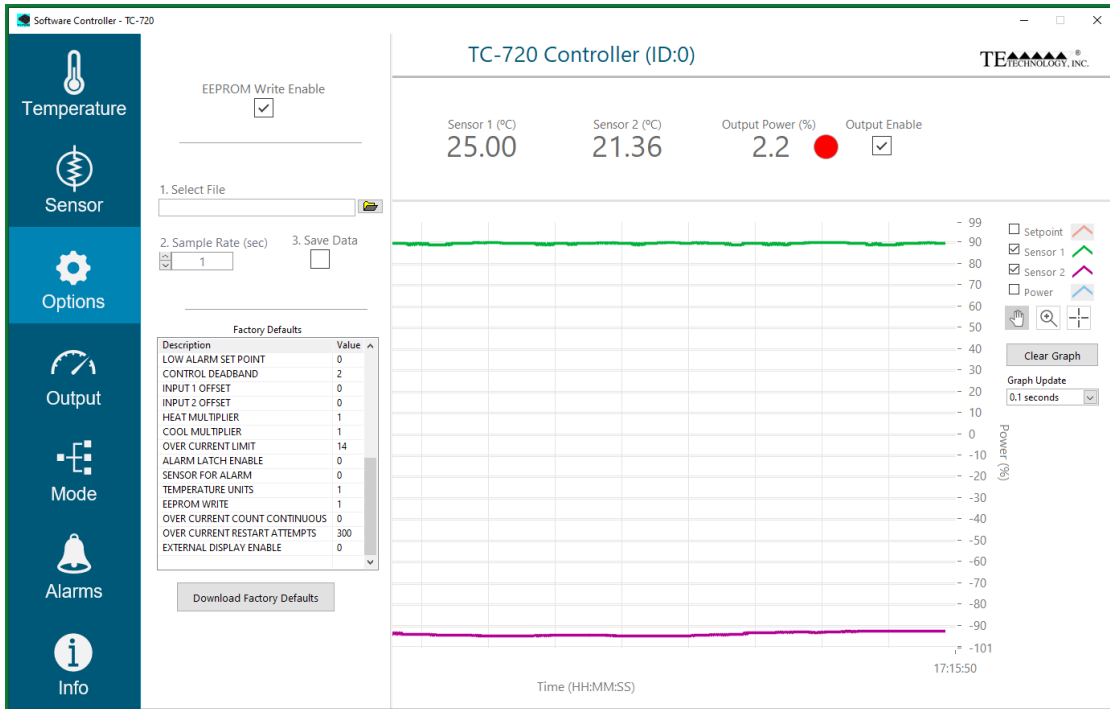

### EEPROM Write Enable

The controller has non-volatile memory (EEPROM—Electrically Erasable Programmable Read Only Memory). This allows the controller to remember its settings even after power to the controller has been turned off. When the software is started, the EEPROM WRITE ENABLE is automatically turned on (box is checked) regardless of whether EEPROM WRITE ENABLE was turned off (by unchecking the box) when power to the controller was removed previously. With EEPROM WRITE ENABLE turned on, any changes to the controller settings are automatically written to EEPROM. With EEPROM WRITE ENABLE turned off, any subsequent changes to the controller settings are only saved in RAM and will not be stored to EEPROM. The maximum number of writes to an EEPROM location is 1,000,000. Even though this provides for many write cycles, you might want to turn EEPROM WRITE ENABLE off if, for example, you are writing your own code and to debug.

### *Data logging:*

#### 1. SELECT FILE

Enter a pre-existing filename in the text box, including the entire path to the file, such as <C:\PROGRAM FILES\TE TECHNOLOGY\TC-720\TESTDATA.TXT>. You can also click the folder icon to select an existing file. **NOTE:** The program will not automatically create a new file. A empty .txt file must be created first and then selected for data to be saved to it.

#### 2. SAMPLE RATE

Determines the amount of time the software waits before updating the status of the controller. This is particularly useful if you will be operating controller for a long time and you want to limit the amount of data you save. The minimum time is 1 second, and it can be adjusted in 1 second increments.

### 3. SAVE DATA

Check the box to begin logging data. The software saves the data into a TAB-delimited format which can then be readily imported into a spreadsheet program for further analysis.

*To view the data in Microsoft Excel:*

1. *Open a blank worksheet*
2. *Select **Data > Import External Data > Import Data**, and click **Next***
3. *Select the file you wish to import and click **Next***
4. *Choose to import **Delimited Data Type** and click **Next***
5. *Select **TAB** as the delimiter and click **Finish***

### DOWNLOAD FACTORY DEFAULTS

Clicking this button will download the original default controller settings to the controller, including ramp/soak program values. You can review these settings by clicking on the scroll bar which will then show the DESCRIPTION of the setting and its VALUE. These default settings cannot be changed.





## OUTPUT menu

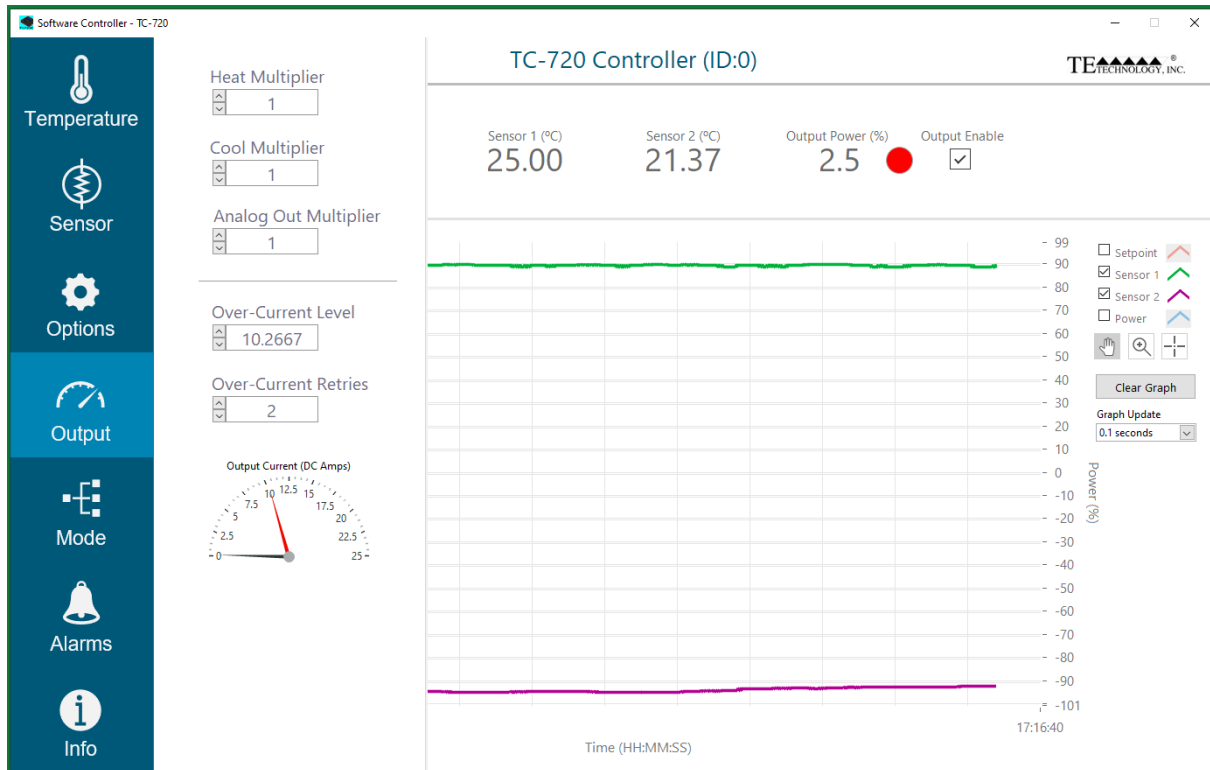

### HEAT MULTIPLIER and COOL MULTIPLIER

These values scale the output power level by the product of the multiplier and output power level. The HEAT MULTIPLIER could be set to 0.00, for example, and then the controller would behave essentially as a cool-only controller. Alternatively, it could be set for some fractional value between 0.00 and 1.00. This is useful if you were cycling between heating and cooling by manually entering two different set point temperatures, and the controller had only been tuned for the cooling set point. TE devices are very effective heaters, so by reducing the heating output, it may be possible to achieve good control stability for both temperatures by only adjusting the HEAT MULTIPLIER rather than by having to manually enter two different sets of tuning parameters for each set point temperature.

### ANALOG OUTPUT MULTIPLIER

When the controller is used in analog mode (set in the MODE menu), this value scales the analog output signal by the product of the multiplier. The controller typically provides a 0-10 Vdc analog signal that can be used with a programmable power supply. However, the ANALOG OUTPUT MULTIPLIER can be set from 0 to 100% to proportionally reduce this maximum voltage. When it is set to 1, the analog output voltage ranges the full 0 to 10 V. If it were set to 0.50, then the analog output voltage would range from 0 to 5 V. This can be useful for limiting the output voltage of the programmable power supply, or for programmable power supplies that require input voltages of less than 10 V.

*The analog output signal is generated by filtering and then buffering a PWM signal from the microcontroller. Limiting the analog output signal with the ANALOG OUTPUT MULTIPLIER effectively reduces the maximum duty cycle of the PWM signal before it is filtered and buffered. Thus, when using it, the number of discrete output levels will also be reduced, thereby limiting the resolution of the voltage control. Because of this, users may find it preferable to keep the ANALOG OUTPUT MULTIPLIER set to 1 and use an external voltage divider.*

#### OVER-CURRENT LEVEL

This sets the maximum current (in amps) that the controller will allow before shutting off output power to the TE device in the event the current exceeds the indicated amount.



The output current is measured using a resistor. However, the actual current value at any given time may vary somewhat from the level indicated by the OUTPUT CURRENT meter due to tolerances of the resistor as well as how quickly the controller can report the current to the computer. In the same manner, the actual current level at which the controller may shut down output may differ slightly from the amount indicated in the OVER CURRENT LEVEL.



NOTE: THIS IS NOT AN ANALOG CURRENT-LIMITING FEATURE!

#### OVER-CURRENT RETRIES

This sets the number of times the controller will automatically attempt to restart and send output power before disabling the output and not attempting further retries. A value of 30000 will set the retries to an infinite amount. This allows the over current level to be set at a reasonably safe level while also allowing for momentary changes in the apparent electrical resistance when the controller switches between heating and cooling.



It is *normal* to have an output current surge when the direction of current flow is instantaneously reversed to a TE device that already has a temperature difference established across it. When this happens, the apparent electrical resistance of the TE device is lower because the Seebeck voltage does not immediately reverse polarity. The reversal of current will eventually reverse the temperature difference across the TE device, and then the Seebeck voltage will likewise change polarity. As the temperature difference reverses, the current will revert back down to a steady-state level.

If the output is disabled due to an over-current condition, the controller can be restarted by clicking the CLEAR LATCHES button in the ALARMS menu, or by cycling power to the controller, or by pressing and holding the UP arrow on the controller itself (TC-720 only) for three seconds.

#### OUTPUT CURRENT (DC AMPS)

The black arm shows the present current draw. The red arm shows the OVER-CURRENT LEVEL.



Mode

## MODE menu

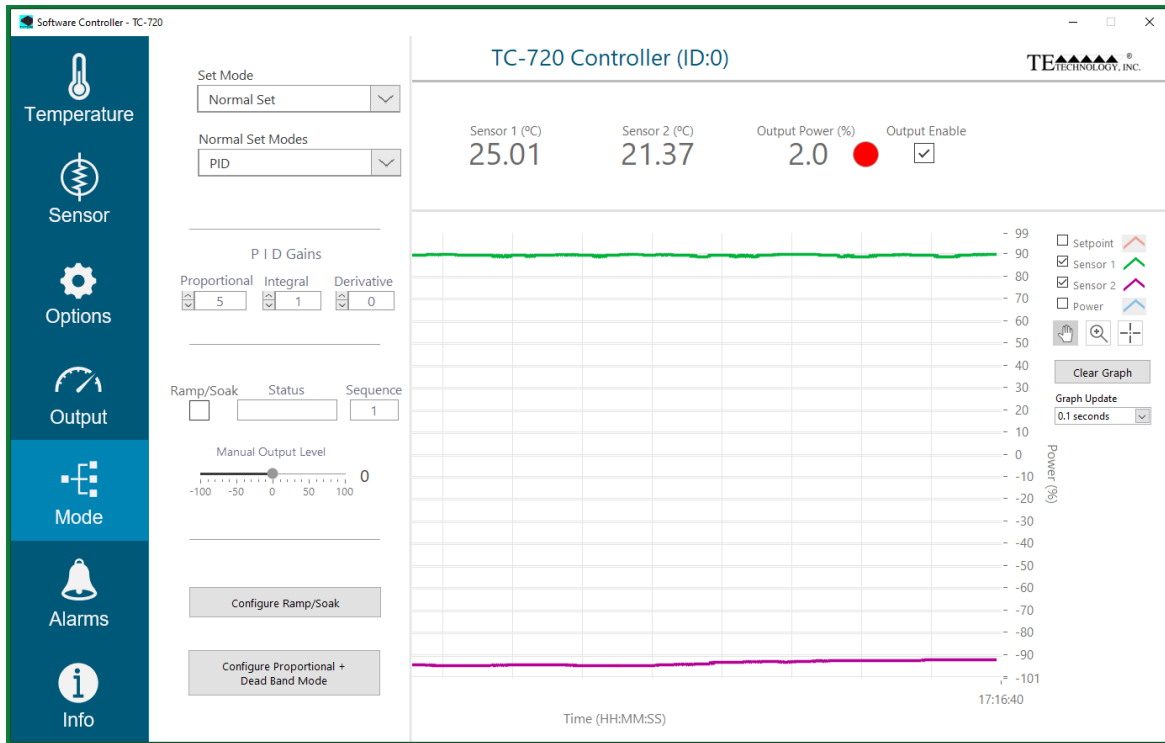

SET MODE can be set to one of three control modes:

1. **NORMAL SET**—the controller will maintain either a single set point temperature or a fixed percentage output power, or it can send an analog signal for a programmable power supply determined by the NORMAL SET MODES selection:
  - i. **PID**—this allows the controller to automatically control to a single set point temperature. The controller can be tuned for control stability by adjusting the “P I D Gain” values in the PROPORTIOANL, INTEGRAL, and DERIVATE boxes. See **3.0 Controller Tuning** above for information on how to tune the controller. See also the OUTPUT menu for adjusting the HEAT MUTIPLIER and COOL MULTIPLIER.
  - ii. **MANUAL**—this allows the controller to provide a fixed percentage of output power. The output power can be set by adjusting the scale pointer in the MANUAL OUTPUT LEVEL section or by directly entering a percentage output level (select the number to the left of the scale). Generally, entering a negative value will cause the TE device to cool, and a positive value will cause the TE device to heat.
  - iii. **ANALOG OUT**—this allows the controller to be used with an external, variable-voltage programmable DC power supply to provide true analog control (not pulse width modulated control). The main difference in ANALOG OUT mode is the output of the H-bridge is forced to always be either +100% or -100% depending on whether the controller is calling for heating or cooling. There is no pulse-width modulation of the voltage that is put into JP7-3 and JP7-4. The H-bridge circuitry within the controller is used strictly to control the polarity of the voltage to the thermoelectric device and is not used to vary the magnitude of that voltage. The magnitude of the voltage to the thermoelectric device is controlled by the analog output signal and a

programmable linear-output power supply. Temperature control is achieved in the following manner:

- a) The analog output signal on JP2-5 is used to send a 0 to 10 Vdc analog control signal to an external linear power supply. This 0-10Vdc signal corresponds to 0 to 100% output power and is independent of the required output polarity (it is magnitude only). See also the ANALOG OUTPUT MULTIPLIER in the OUTPUT menu for additional details where the maximum output signal can be reduced to match the requirements of the power supply you intend to use.

NOTE: The analog output is always present, regardless of whether the controller is in ANALOG OUT mode or not.

- b) The linear-output programmable power supply uses this 0-10V control signal to adjust its output from 0 V to its full-scale voltage. This creates a high-power, variable analog voltage for the TE device.
  - c) The voltage generated by the linear-output power supply is fed back into controller at JP7-3 and JP7-4.
  - d) The polarity of this voltage is then kept positive or reversed depending on if heating or cooling is needed (H-Bridge output is +100% or -100%)
  - e) The voltage is sent to the thermoelectric device at terminals JP7-1 and JP7-2. Thus, full linear control with both magnitude and polarity is accomplished.
2. RAMP/SOAK—the controller will follow a sequence of set points defined by the ramp/soak profile. See CONFIGURE RAMP/SOAK below for further details.
  3. PROPORTIONAL+DEAD BAND—the controller will provide linear power output between two temperatures in both heating and cooling mode. A dead band is allowed between these heating and cooling points where no power is sent to the thermoelectric devices. This is useful with outdoor enclosures that have a broad operating temperature range and only need cooling or heating at times of extreme temperatures. Otherwise, when the enclosure temperature is within the pre-defined temperature range, output power can be off in order to save energy. See CONFIGURE PROPORTIONAL+DEAD BAND MODE below for further details.

## CONFIGURE RAMP/SOAK

Clicking on the “CONFIGURE RAMP/SOAK” OK button calls up the following screen (the values populating the cells will depend on whatever was last configured):

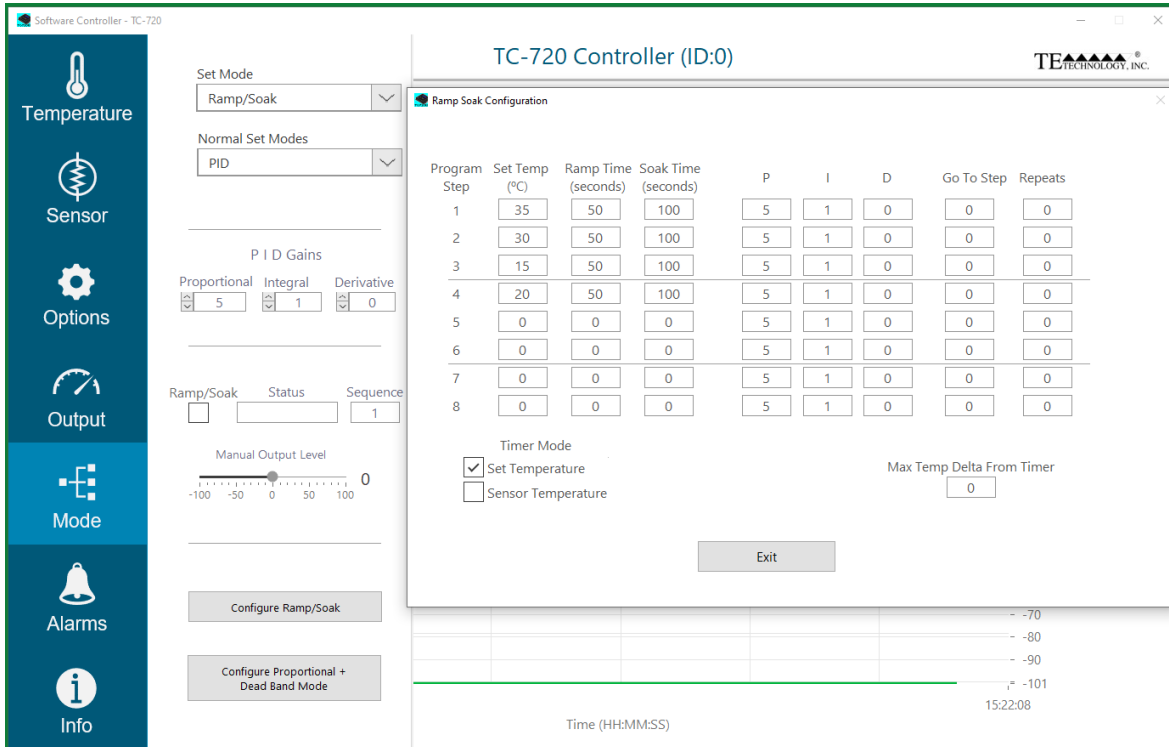

The Ramp/Soak configuration contains 8 program steps. Each step has settings for the following:

1. Set Temp.—the set temperature that the controller should maintain
2. Ramp Time—the approximate amount of time the controller should take to reach the set temperature
3. Soak Time—the amount of time the controller should maintain the set temperature before proceeding to the next step
4. (P)roportional, (I)ntegral, (D)erivative—these are the control stability parameters used for the given set point temperature
5. Go To Step--determines which step should be run after completion of the repeats. Go To Step can only be to the same or a lower segment. No skipping forward is allowed. The Go To Step parameter needs to be used in conjunction with the Repeats parameter.
6. Repeats—specifies how many times a given set of steps is performed before moving on to the next step. Remember, this is the number of repeats *in addition to* the first-time completion of the number of steps, so the total number of times the steps will be completed will be the number of repeats plus one (N+1).

Note: the maximum ramp time or soak time for any given step is 32,767 seconds. The maximum number of repeats is 32,766.

The TIMER MODE can be configured to use the SET TEMPERATURE or the SESNOR TEMPERATURE. If the timer mode uses the set temperature, then the amount of soak time, for example, begins counting as soon as the program step begins regardless of the actual temperature of the sensor. If the sensor temperature is used, then the time will begin counting only when the actual temperature of the sensor has reached the set temperature. However, the MAX TEMP DELTA FROM TIMER can be set to allow timing to begin as soon as the Temperature Delta (or difference) between the actual sensor temperature and the set temperature is within the specified range. The allowable range for the Temperature Delta is 0.00 °C to 20.00 °C.

*An example of Ramp/Soak programming is provided in Appendix D.*

Once the Ramp/Soak programming is completed, click the EXIT button. Then click the RAMP/SOAK check box to run the program. The program Status and Sequence step are displayed when the program is running.

To exit out of the ramp/soak program before it has completed, uncheck the RAMP/SOAK box.

When a ramp/soak program has completed, the controller will set the output% to zero, and the software will pop up indicating completion:

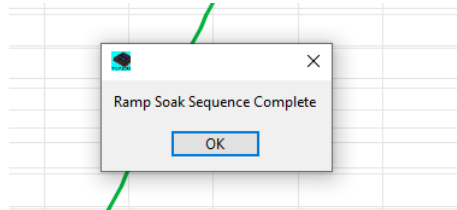

To run the program again, click the OK button, then re-check the RAMP/SOAK box.

## CONFIGURE PROPORTIONAL + DEADBAND MODE

This feature is typically used with air-to-air cooling assemblies (TE Technology AC-XXX models) when controlling the internal temperature of an enclosure. This is particularly useful to minimize power usage for applications that have a relatively wide portion of their operating temperature range in which heating or cooling is not required. The controller would only apply power if the sensor temperature were at the extremes of the operating temperature range.

Clicking on the CONFIGURE PROPORTIONAL+DEADBAND MODE button calls up the following screen:

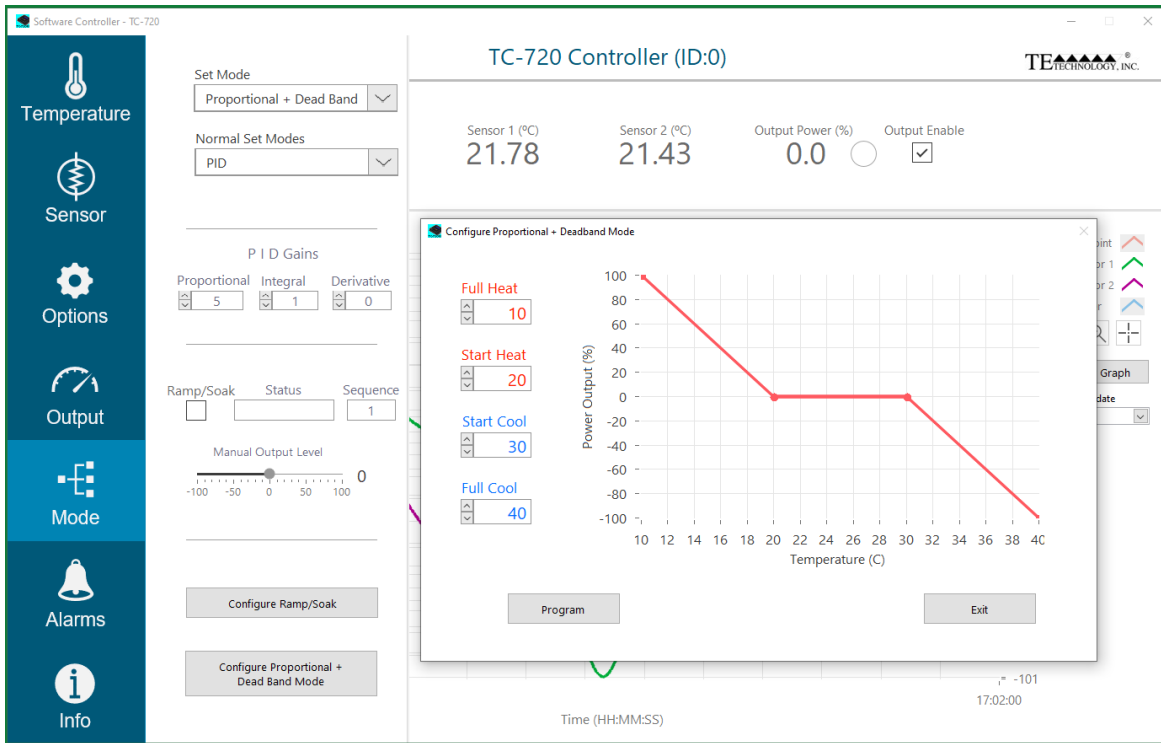

The controller can be configured so that power is applied proportionally based on four different temperatures. The controller provides no power output when the sensor temperature is between the two temperatures defined by START HEAT and START COOL. If the sensor temperature were to drop below the START HEAT temperature, the controller would then begin proportionally increasing power in the heating mode such that 100% would be applied if the sensor temperature were to decrease to (or go below) the FULL HEAT temperature. Likewise, if the sensor temperature were instead to start increasing past the START COOL temperature, then the controller would begin proportionally increasing power in the cooling mode from such that -100% would then be applied if the sensor temperature were to increase to (or exceed) the FULL COOL temperature.



For this feature to work properly, be sure that the FULL HEAT temperature is less than the START HEAT temperature. Similarly, be sure that the FULL COOL temperature is greater than the START COOL temperature.

Click the PROGRAM button to save the temperatures to the controller.

**Controlling fans when using PROPORTIONAL + DEADBAND MODE:** It may be desirable to de-energize the TE device's fan when using this mode. For example, it may not be necessary or desirable for the fan on the external heat sink to always be energized, even when the enclosure is being heated. In this case you may wish to use ALARM 2 (see the ALARMS menu) to energize and de-energize the fan. To accomplish this, the following steps would be taken:

1. The negative terminal of the external fan would be connected to the ALARM 2 terminal, JP2-10. If using a TE Technology standard cooling assembly, be sure to remove the electrical jumper in the terminal block which connects the negative terminal of this fan to the negative terminal of the internal fan.
2. The ALARM 2 FUNCTION is set to KEEP OUTPUT ON
3. ALARM 2 SENSOR is set to INPUT 1 (the internal temperature)
4. The HIGH ALARM 2 SETTING is set to the temperature at which the fan is to be turned on. For the example screen above this could be 25 °C.
5. The LOW ALARM 2 setting is turned off
6. The ALARM 2 DEADBAND is set to some non-zero number, for this example assume it is set to 2 °C. This deadband keeps the external fan from turning on and off due to slight fluctuations in the internal temperature. *Be careful to set the HIGH ALARM 2 SETTING and ALARM 2 DEAD BAND so that the external fan is always energized whenever cooling power is being applied to the thermoelectric modules.*
7. The internal fan is wired to always be operating. That helps maintain a uniform internal enclosure temperature, and when the controller applies heating power to the thermoelectric modules the internal fan distributes the heat from the fins and keeps the thermoelectric modules from overheating.

Thus, for the example and fan control description above, the external fan would be energized whenever there is a high alarm, in this case when the internal temperature increases to 25 °C. When the internal temperature decreases to 23 °C (corresponding to a 25 °C HIGH ALARM 2 SETTING minus the 2 °C ALARM 2 DEADBAND temperature), the ALARM 2 will turn off, and the fan will be de-energized. The internal temperature will then need to rise to 25 °C before the external fan will be energized again.

Referring again to the example above, the controller would start cooling when the internal temperature is at 30 °C, and increase to full cooling when the temperature is above 40 °C. If the internal temperature drops to 20 °C the controller will start applying heating power, and the controller will be applying full heating power when the internal temperature has decreased to 10 °C.

This method of energizing and de-energizing the fan is useful in that it allows a defined temperature range when both the internal and external fans are to be energized while the thermoelectric modules are not energized. This is an energy-saving feature because the thermoelectric assembly can be used to passively conduct heat through the thermoelectric modules to the outside of the enclosure while only powering the fans.

An alternative method is to control the fan using the FAN CONTROL mode in conjunction with the ALARM 1 SIGNAL. However, in using this mode, the fan will not be de-energized until heating power is being applied to the thermoelectric modules, in this example at 20 °C. Then, the fan would not be re-energized until cooling power is being applied, in this example 30 °C.

For more information on configuring the alarms, see the ALARMS menu section of the manual below.





# ALARMS menu

Software Controller - TC-720

TC-720 Controller (ID:0) TE<sup>▲▲▲▲▲▲</sup> TECHNOLOGY, INC.

Sensor 1 (°C) 25.00    Sensor 2 (°C) 21.38    Output Power (%) 2.2    Output Enable

Alarms Status: No Alarms

Alarm 1 Signal: Switch With Alarm

Alarm 1 Function: Turn Off Output

Alarm 2 Function: Turn Off Output

Alarm 2 Sensor: Input 2

Alarm Latches: Alarm 1 & 2 Latch

Interlock: Disabled

	Alarm 1	Alarm 2
High	70	70
Low	-20	-20
Deadband	0	0

Buttons: Clear Latches, Fan Control Settings

Graph: Power (%) vs Time (HH:MM:SS)

Graph Legend: Setpoint (red), Sensor 1 (green), Sensor 2 (purple), Power (blue)

Graph Update: 0.1 seconds

Time: 17:19:10

The ALARMS menu provides settings for how the controller will respond if an alarm condition occurs. It also provides settings for fan-speed control.

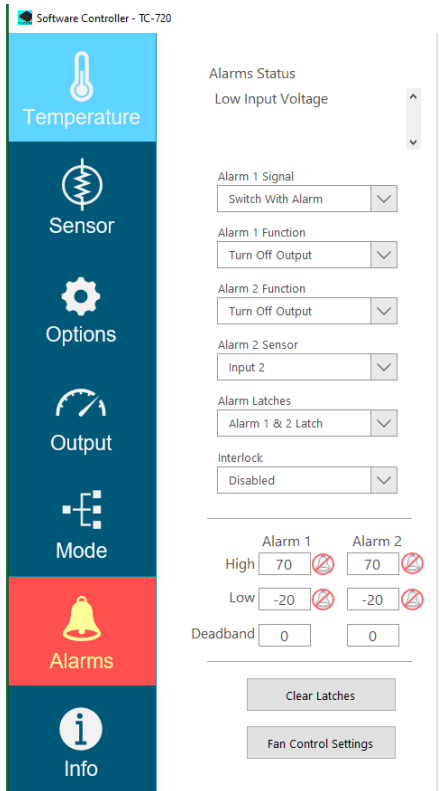

If an ALARM condition exists, the ALARMS menu icon will flash in red as shown here. Clicking on the ALARMS menu button will then show in the Alarms Status section one or more applicable alarms. In this example, a Low Input Voltage condition exists. In such a case, there is still enough power to communicate with the controller, but the output stage has been deactivated to prevent damage to the circuitry.

#### ALARM 1 SIGNAL provides three options:

1. **SWITCH WITH ALARM:** if an alarm condition occurs based on the control sensor, the Alarm 1 transistor will turn on and short the JP2-8 terminal to ground. (See section 1.5 for an example of how an external LED could be used to visually indicate an alarm condition is occurring).
2. **FAN CONTROL + :** the controller can be configured to provide fan speed control based on the output power provided by the controller. (The controller does not accept tachometer feedback; it will only provide pulse-width modulation (PWM) based on the output power being sent to the TE device, which is indirectly related to the feedback from the control sensor.) Select this option if the fan uses a PWM control signal where increasing the amount of time that the fan-speed wire is shorted to ground would cause an increase in fan speed. (The fan-speed wire is connected to the Alarm 1 transistor, and the controller pulse-width modulates the Alarm 1 transistor.)
3. **FAN CONTROL - :** Select this option if the fan uses a PWM control signal where decreasing the amount of time the fan-speed wire is shorted to ground causes an increase in fan speed. Most fan-speed control fans will use this setting, but you will need to consult with the manufacturer to determine which setting is appropriate.



When programming or adjusting the fan control settings, always monitor and verify that the TE device and the fan operate as intended and within the safe operating limits under all applicable operating conditions.



Fan control should only be used with fans that are specifically designed to be speed controlled using PWM. Using PWM control on a fan not designed for it can create a hazardous condition by damaging or overheating the controller, the fan, and the TE device.



The fans used in TE Technology's Thermoelectric Cooling Assemblies are NOT designed to be speed controlled using PWM unless specifically indicated as such in the product literature.



Do not use fans whose current would exceed 2.0 A, including instantaneous peak/inrush current which can occur at the leading edge of the PWM waveform.



Reducing fan speed will reduce air flow and result in a warmer heat-sink operating temperature. This will then reduce the heat pumping capacity of the TE device. It may also reduce the maximum allowable ambient temperature in which the TE device can be safely operated. If the fan speed is too low, it may cause the heat-sink temperature to exceed the maximum temperature rating of the TE device.



Most fans designed for PWM control require a 5 V signal, although some fans have built-in circuitry that may allow for a higher voltage. In addition, you may need to add a pull-up resistor to limit current flow through the fan circuitry. Consult with the fan manufacturer for further details.

#### ALARM 1 FUNCTION:

1. KEEP OUTPUT ON: if an alarm condition exists based on the control sensor temperature being above the temperature entered in the HIGH ALARM 1 box, or if the control sensor temperature is below the temperature entered in the LOW ALARM 1 box, the controller will continue to provide output power to the TE device regardless of the alarm condition.
2. TURN OFF OUTPUT: if an alarm condition exists based on the control sensor temperature relative to the HIGH ALARM 1 or the LOW ALARM 1 settings, the controller will shut off output power to the TE device.

#### ALARM 2 FUNCTION:

1. KEEP OUTPUT ON: if an alarm condition exists based on the secondary sensor temperature being above the temperature entered in the HIGH ALARM 2 box, or if the secondary sensor temperature is below the temperature entered in the LOW ALARM 2 box, the controller will continue to provide output power to the TE device regardless of the alarm condition.
2. TURN OFF OUTPUT: if an alarm condition exists based on the secondary sensor temperature relative to the HIGH ALARM 2 or the LOW ALARM 2 settings, the controller will shut off output power to the TE device.

#### ALARM 2 SENSOR:

1. INPUT 1: the Alarm 2 transistor turns on if an alarm condition exists relative to the control sensor.
2. INPUT 2: the Alarm 2 transistor turns on if an alarm condition exists relative to the secondary sensor.

### ALARM LATCHES:

Alarm latches, when enabled, hold the alarm transistor signals and power output state as if they were in an alarm condition, even if the temperature conditions that caused the alarm are no longer present. Alarm latches can be cleared by clicking the CLEAR LATCHES button or by pressing the “up arrow” for 3 seconds (TC-720 only) or by de-energizing and re-energizing the temperature controller.

1. NO LATCHES: if an alarm condition occurs but then the condition clears itself, the alarm will automatically reset, and the controller will resume normal operation.
2. ALARM 1 LATCH: if an alarm is triggered from the control sensor, the software will continue to signal an alarm condition until the condition is cleared *and* the “latch” is cleared by one of the methods described above (for example, clicking the CLEAR LATCHES button). If an alarm condition is triggered by the secondary sensor, but then clears itself, Alarm 2 will automatically reset, and the controller will resume normal operation.
3. ALARM 2 LATCH: if an alarm is triggered based on the secondary sensor, the software will continue to signal an alarm condition until the condition is cleared *and* the “latch” is cleared by one of the methods described above (for example, clicking the CLEAR LATCHES button). If an alarm condition is triggered by the control sensor, but then clears itself, Alarm 1 will automatically reset, and the controller will resume normal operation.
4. ALARM 1&2 LATCH: if an alarm is triggered from either the control or the secondary sensor, the software will continue to signal an alarm condition until the condition is cleared *and* the “latch” is cleared (for example, by clicking the CLEAR LATCHES button).

### INTERLOCK:

When ENABLED, the INTERLOCK terminal (JP2-6) must be shorted to the controller circuit ground (LOGIC SUPPLY JP2-7 or POWER GROUND JP7-3) in order to enable the main output of the controller. If the JP2-6 is not shorted to circuit ground (i.e., it is open circuit) then the main output of the controller is disabled.

The interlock latch can be cleared by clicking the CLEAR LATCHES button in the GUI, by pressing the “menu key” + “up arrow” for 3 seconds (TC-720 only), or by de-energizing and re-energizing the temperature controller.

1. DISABLED: whether the INTERLOCK terminal is shorted to ground or is open circuit, it will have no effect on the main output of the controller.
  2. ENABLED NO LATCHING: Main output will be disabled if the INTERLOCK terminal is not shorted to ground. The main output will automatically be enabled again once the INTERLOCK terminal is shorted to ground.
  3. ENABLED WITH LATCHING: Main output will be disabled if the INTERLOCK terminal is not shorted to ground. It will only be enabled once the INTERLOCK terminal is shorted to ground *and* the “latch” is cleared by one of the methods described above (for example, by clicking the CLEAR LATCHES button).
- The Interlock is typically used as a safety feature with an external switch or thermostat.
  - The controller has an internal 2.5 K $\Omega$  pull-up resistor connected to JP2-6, see Controller Schematic.
  - When the interlock has disabled the output, the LCD screen on the TC-720 (non-OEM version) will flash “ILOPEN” (for INTERLOCK OPEN).
  - Do *not* short INTERLOCK to controller chassis safety ground.

HIGH ALARM 1: This sets the temperature at which an alarm will occur if the control sensor temperature exceeds the entered value. Only integer values are accepted. The set value must be greater than the value set in the LOW ALARM 1 but less than 201 °C. If the set value is set to greater than 200 °C, no alarm will be signaled for any over-temperature condition, essentially turning off the high alarm setting.

LOW ALARM 1: This sets the temperature at which an alarm will occur if the control sensor temperature becomes less than the set value. Only integer values are accepted. The set value must be less than the HIGH

ALARM 1 but greater than -61 °C. If the set value is less than -60 °C, no alarm will be signaled for any under-temperature condition, essentially turning off the low alarm setting. (Note: When using firmware revision J or earlier, these values are limited to -41 °C and -40 °C, respectively.)

DEADBAND ALARM 1: this defines a temperature difference above or below the LOW ALARM 1 or HIGH ALARM 1 at which the alarm status can be cleared (either automatically or manually depending on latch settings). Only integer values are accepted. For example, if the HIGH ALARM 1 is set for 70 °C and the DEADBAND ALARM 1 is set for 10 °C and an alarm condition occurs, the control sensor would have to cool to 60 °C before the alarm could be reset.

The HIGH ALARM 2, LOW ALARM 2, and DEADBAND ALARM 2 function in the same manner as described above for ALARM 1 settings except that they are referenced to the secondary sensor, assuming that the ALARM 2 SENSOR setting is configured to use INPUT 2.

Note: clicking the  button provides a shortcut for turning off the HIGH and LOW alarm settings.

### FAN CONTROL SETTINGS

*PRINCIPAL OF OPERATION*: Fan speed control is designed to adjust the speed of the heat sink fan only. It allows the fan to operate at reduced speeds and is used when the resulting loss of cooling capacity during speed regulation is an acceptable tradeoff for achieving lower fan noise. The fan speed is modified as a function of the percentage of output power being commanded to the TE device (main output%).

Fan speed is controlled by generating a PWM signal with the Alarm 1 output transistor. This is an open-drain field effect transistor. The Alarm 1 terminal (JP2-8) is either electrically shorted to ground or allowed to remain open relative to ground to achieve the desired control.

The “FAN CONTROL+” setting causes the Alarm 1 output to be electrically shorted to ground at an increasingly higher rate when a faster fan speed is desired. The “FAN CONTROL-” setting causes the Alarm 1 output to be electrically open to ground at an increasingly higher rate when a faster fan speed is desired. The appropriate setting is dependent on the fan. When using a two-wire fan, the negative fan wire is typically attached to the Alarm 1 terminal (JP2-8), and increasing the amount of time that the transistor is shorted to ground will increase the fan speed. You would use “FAN CONTROL+” for this set up. Conversely, when the fan includes a separate terminal for speed control, a higher fan speed is typically achieved by *decreasing* the amount of time the speed control terminal is shorted to ground. This is not an absolute convention among fan manufacturers, so consult the fan manufacturer’s specification for proper operating instructions. Additionally, if the fan does not include an internal pull-up resistor on the speed control terminal, an external pull-up resistor may be required.

*As previously mentioned, two-wire fans are not ordinarily designed for fan-speed control in this fashion. Consult with the fan manufacturer to verify whether PWM can be used with the fan before using this feature.*

The FAN CONTROL SETTINGS below determine how the PWM signal is generated by the Alarm 1 output transistor relative to output power being commanded to the thermoelectric device (main output%).

Clicking the FAN CONTROL SETTINGS button brings up the following screen:

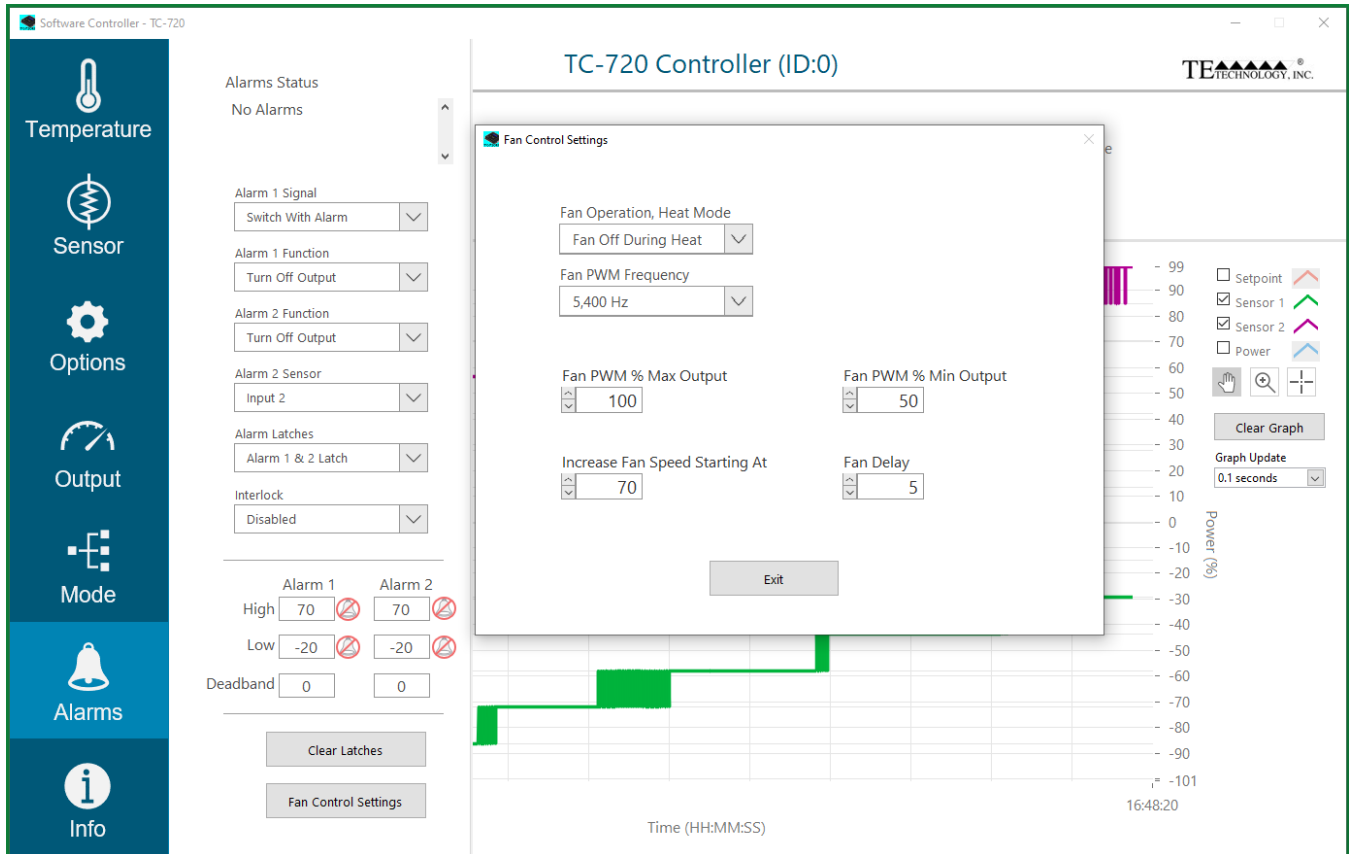

**FAN OPERATION, HEAT MODE** determines how the fan will be powered when the TE device is in the heating mode (main output%  $\geq$  ~1%).

- **FAN OFF DURING HEAT:** turns off output power to the fan when the controller switches to the heating mode.
- **FAN AT LOW DURING HEAT:** applies the minimum level of output to the fan based on the FAN PWM % MIN OUTPUT when the TE device is being powered the heating mode.
- **FAN ON DURING HEAT:** fan runs at full power when the TE device is being powered in the heating mode.

If the FAN OPERATION, HEAT MODE is set to FAN OFF DURING HEAT, there will be a slight delay between when the controller switches into the heating mode and when the fan shuts off. Likewise, there will be a slight delay before the fan restarts when the controller switches into the cooling mode. This helps prevent the fan from cycling on and off frequently if the output is frequently switching between positive and negative values.

For tighter temperature control stability and to avoid having the fan constantly stopping and restarting under certain conditions it is recommended that the FAN OPERATION, HEAT MODE be set to FAN AT LOW DURING HEAT or set to FAN ON DURING HEAT.

**FAN PWM FREQUENCY** can be set to 42 Hz; 169 Hz; 675 Hz; 5400 Hz; or 43,200 Hz. Consult with the fan manufacturer to determine which frequency works best with the particular fan.

FAN PWM % MAX OUTPUT and FAN PWM % MIN OUTPUT levels are adjustable from 0% to 100%. These determine the maximum and minimum % PWM duty cycle for the fan. Only integral values are accepted.

INCREASE FAN SPEED STARTING AT: determines the main output% (to the TE device) at which the fan output should begin proportionally increasing from FAN PWM % MIN OUTPUT to FAN PWM % MAX OUTPUT. FAN PWM % MAX OUTPUT is always reached when the main output% to the TE device is at -100% (cooling mode).

FAN DELAY: The fan speed control incorporates an initial period of operation at 100% duty cycle when the fan is first turned on, before the fan speed is adjusted to the output level according to the main output%. This helps ensure the fan has been given full voltage to start the fan blades spinning before power is decreased. It is useful because fan bearings age, potentially requiring increased start-up voltages. The FAN DELAY determines the maximum amount of time that the fan runs at 100% before being adjusted according to the main output%. This delay happens any time the fan transitions from completely off to on. However, if the FAN OPERATION HEAT MODE is set to FAN OFF DURING HEAT, and the main output% switches from heating to cooling, the fan restarts at 100% duty cycle; if the controller then switches from cooling back to heating before reaching the full time corresponding to the FAN DELAY, the fan will simply turn off before the total FAN DELAY time has passed. The FAN DELAY is not actually a time in seconds, but it is proportional to the amount time in seconds. Each increment in the FAN DELAY box increases the delay time by approximately 2 seconds.

Note: if the COOL SIDE MULTIPLIER (see OUTPUT menu for reference) is set to zero, the FAN DELAY is set to zero, and the FAN OFF DURING HEAT is set, the fan will turn on at the level set by FAN PWM % MIN OUTPUT as soon as the temperature overshoot begins dropping back down. The fan will shut off as the temperature begins dropping below the set point.

EXAMPLE: As shown in “FAN CONTROL SETTINGS” screen view above, the PWM frequency for the fan is set to 5,400 Hz. The fan PWM% will run at 50% while the main output% is between 0% and -70% in the cooling mode. The fan PWM% will then proportionally increase from 50% to 100% as the main output% increases from -70% to -100%. The fan will be off when in heating mode (main output%  $\geq$  ~1%). This can be seen in the graph below. If the controller switches from heating mode to cooling mode, there will be a delay of approximately 10 seconds before the fan PWM% is adjusted according to the main output% level. During these 10 seconds the fan PWM% will be 100% (unless the controller switches back to the heating mode before the 10 seconds has passed, in which case, the fan would again shut off).

Additional information and examples are shown in Appendix E– “Additional Notes on Fan Control”

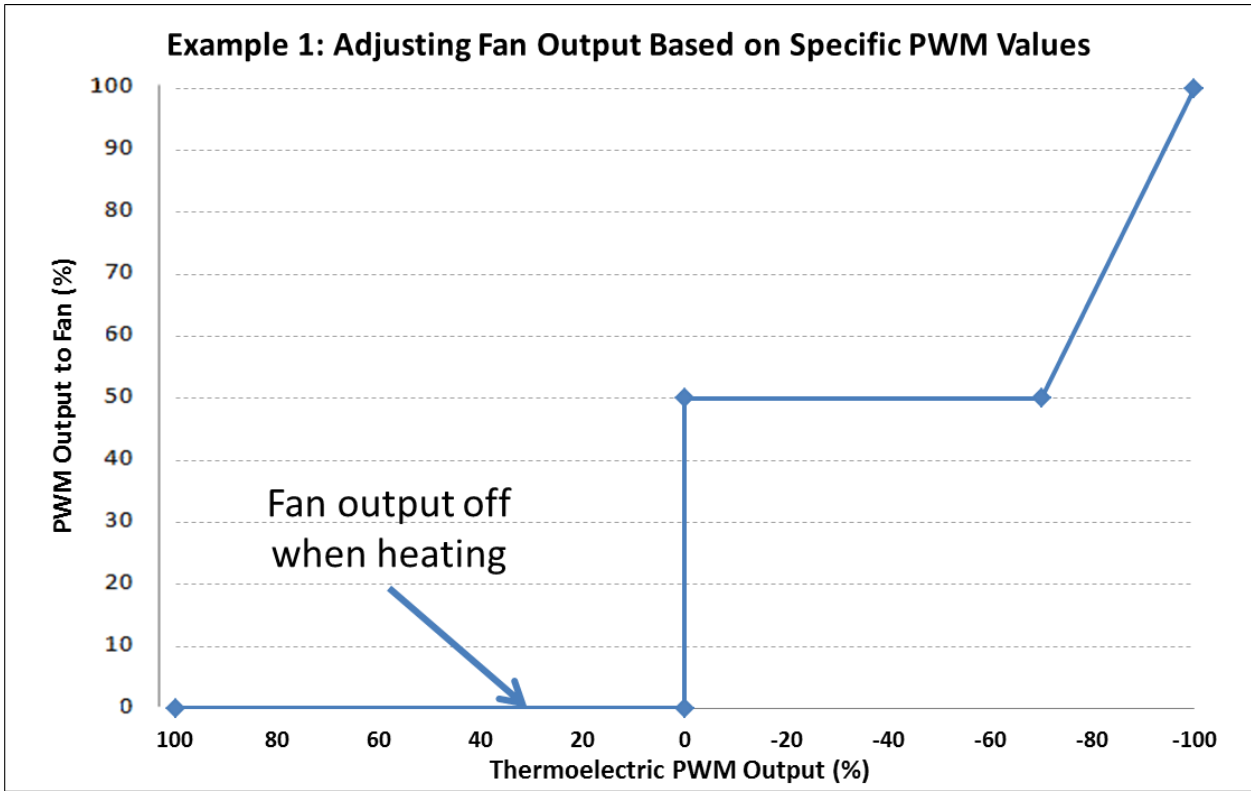

Example 1 Parameter	Setting
FAN OPERATION, HEAT MODE	FAN OFF
FAN PWM % MAX OUTPUT	100 %
FAN PWM % MIN OUTPUT	50 %
INCREASE FAN SPEED STARTING AT	70 %

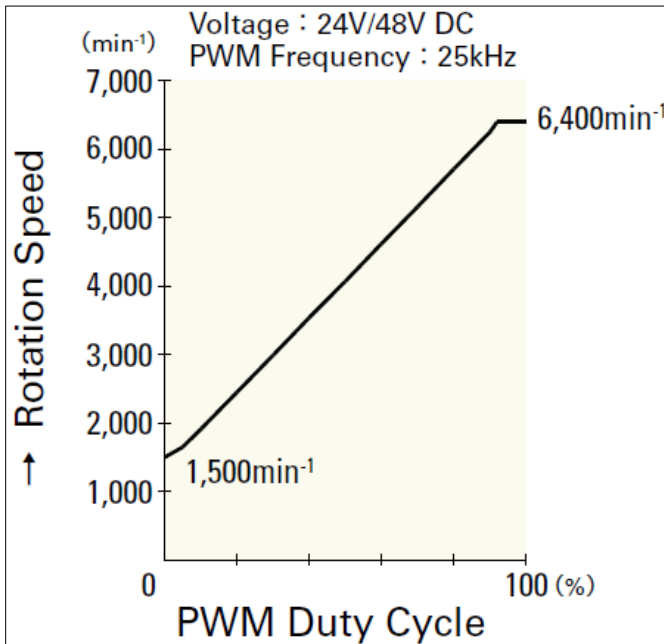

NOTE: If the fan has been operating using fan control mode, and then the ALARM 1 SIGNAL is changed in the GUI from a "FAN CONTROL" mode to "SWITCH WITH ALARM" and then back to a "FAN CONTROL" mode, the controller will not repeat the FAN DELAY cycle of 100% duty cycle

NOTE: Remember that a 0 to 100% span in "PWM Output% to Fan" does not necessarily correlate to a 0 to 100% span of the fan's rotational speed. Many fans will still rotate even when the PWM fan signal is at 0 %. A typical relationship of PWM Output% to Fan versus rotational speed is depicted in the graph to the left.



**Info** **INFO menu**

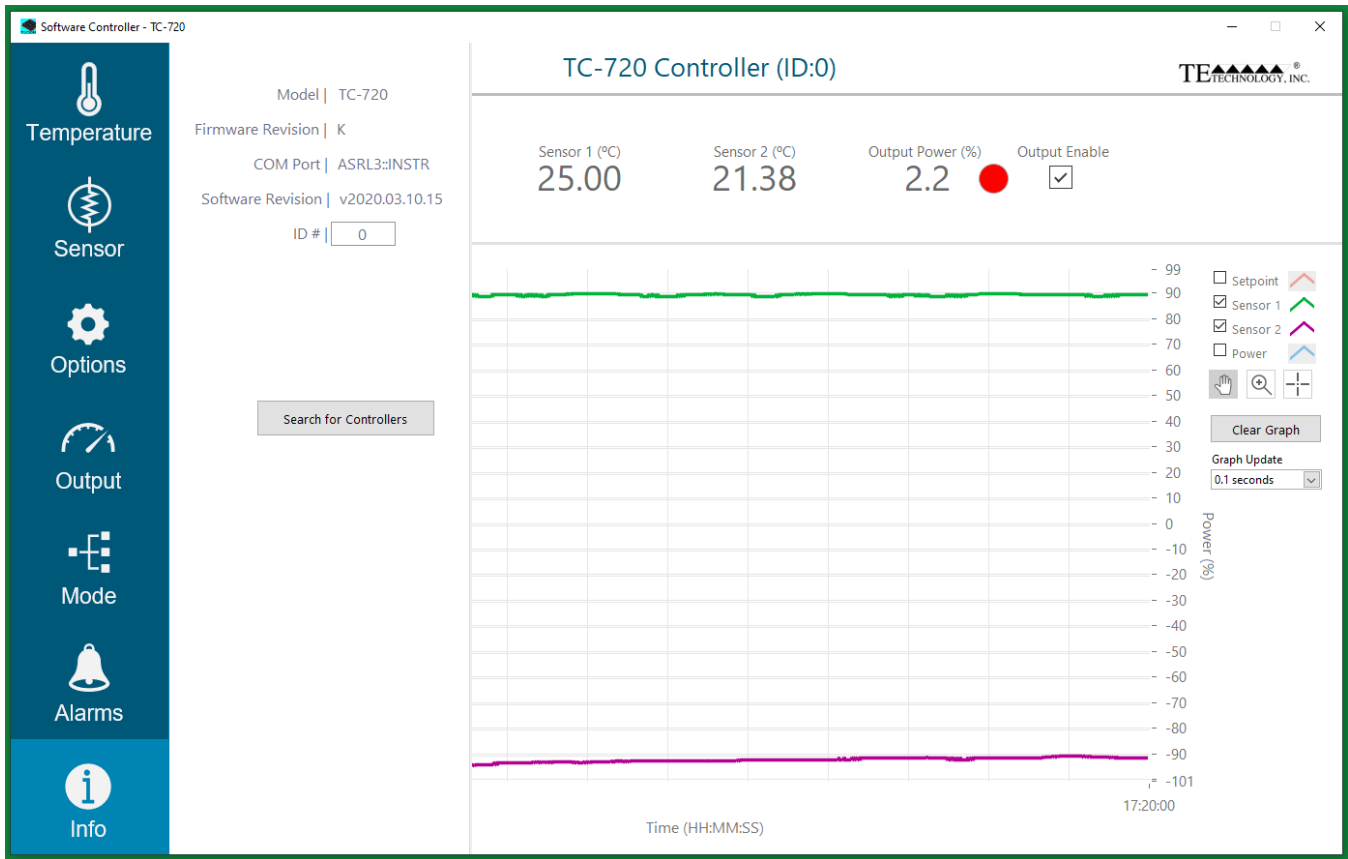

The INFO menu provides basic information on the firmware revision of the controller, the COM port the controller is connected to, and the software revision level.

**ID#:** the controller can be assigned a unique integer number which can help distinguish one controller from another if there are multiple controllers connected to the computer. Typically, the controller has a default ID# of zero. To assign a different number, type in the desired integer in the ID# box and press enter. This box is used for assigning a controller ID# only.

SEARCH FOR CONTROLLERS button: when multiple controllers are connected, clicking this button will search for the all available controllers that can be communicated with as shown in the example below:

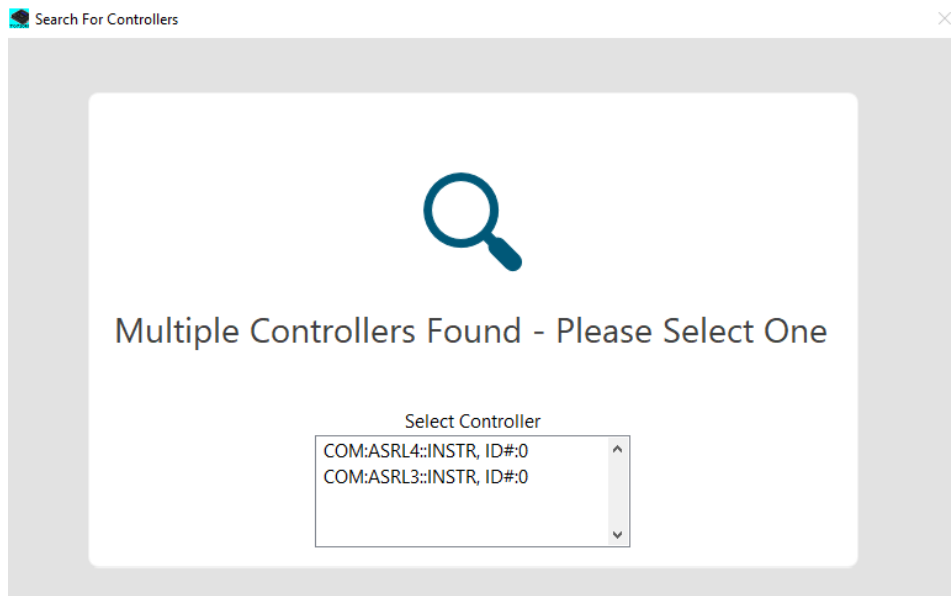

In this example, there are two controllers: one is connected is to COM 3 and the other is connected to COM 4. Both have “ID#0” assigned to them. You can click on the particular controller that you want to communicate with, and the controller will then begin graphing the output of that controller.

At the top of the graph, the controller ID# is shown:

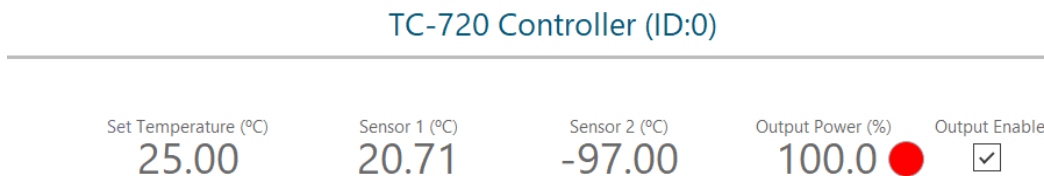

The COM port number is not displayed though. So, if there are multiple controllers connected, it is best to assign a unique ID# to verify that the desired controller output is actually the one that needs to be viewed/communicated with.

**Note: You can only connect to one controller at a time with each instance of the software. If you need to connect to multiple controllers simultaneously you will need to open a separate instance of the software and select a different controller. The controllers that are already in use by other instances of the software will not be populated on the list of controllers.**

# Controller Schematic

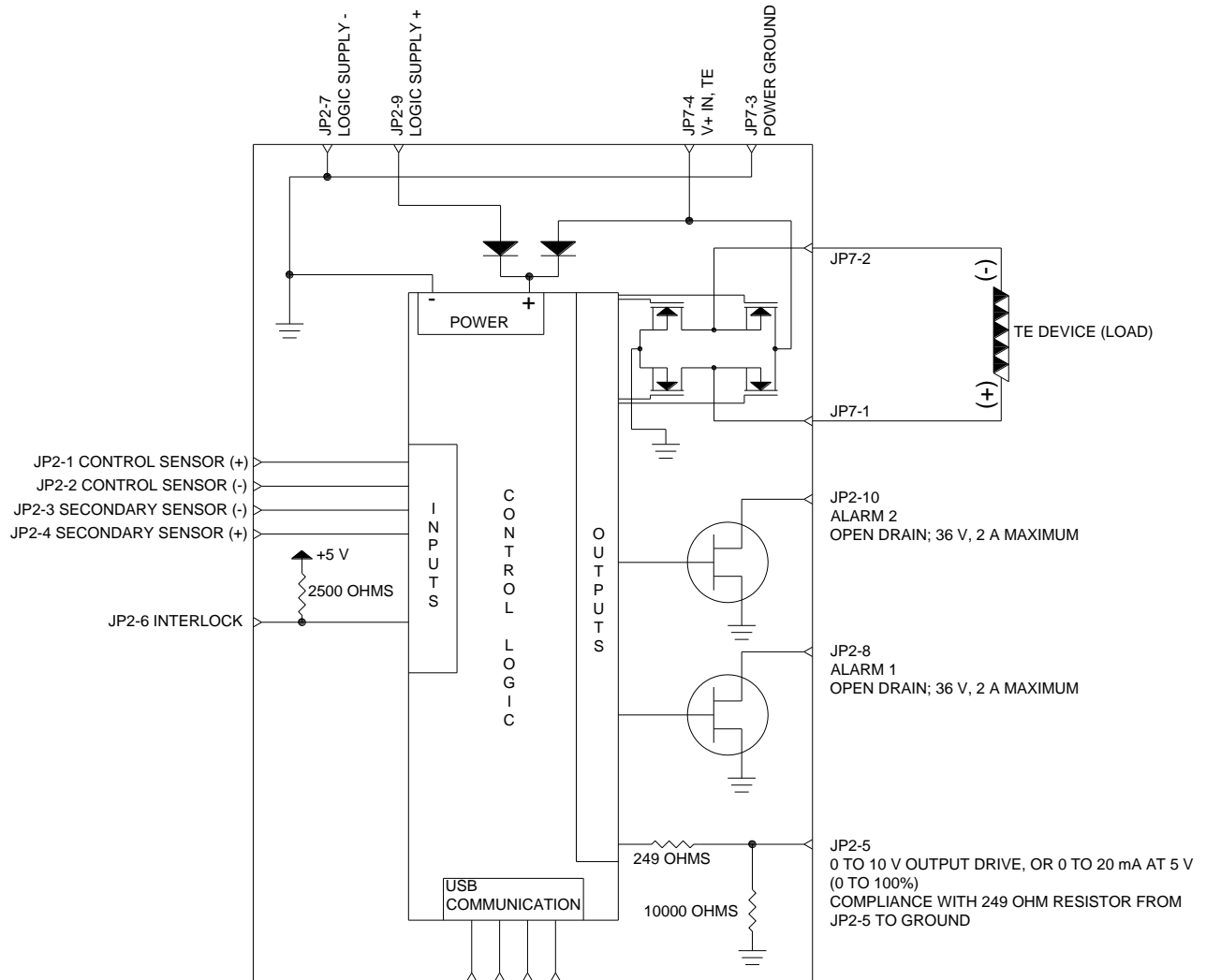

# Troubleshooting Controller

## GENERAL:

Remember you can restore the factory settings to the controller by using the DOWNLOAD FACTORY DEFAULTS feature. This can be accomplished by using the GUI and selecting DOWNLOAD (see CONTROLLER OPTIONS BOX section), or by using the keypad on the TC-720 (Reference Section 2.4.16) and selecting LOAD DEFAULTS. If for some reason there is a setting awry, it may be easier to download defaults rather than trying to determine which of the parameters has been misapplied.

## SOFTWARE NOT RESPONDING

Reference section 4.0, Controller Software and USB Communication for general communication tips.

### BE PATIENT!

When searching for controller address, the amount of time required to find the controller will depend on the amount of USB ports. The controller will send a query to each port and wait a preset time for response. The total time increases when using computers with multiple USB ports or USB hubs.

When changing parameters, the GUI can take 5-10 seconds at times to send all of the required parameters and then verify these parameters have been properly received by the controller. DO NOT press multiple other buttons or change other parameters until each parameter has been properly received and accepted by the controller.

INCORRECT DRIVER MAY BE INSTALLED: A DLL driver may be installed instead of a VCP driver for the USB port. Uninstall the DLL driver. Consult [www.ftdichip.com](http://www.ftdichip.com) to download the VCP driver appropriate for your computer's operating system.

LabVIEW RUNTIME ENGINE MAY NEED UPDATING: Consult [www.ni.com](http://www.ni.com) for the latest runtime engine. The LabVIEW runtime engine is used to run the GUI. Updates to the Windows operating system may in turn require an update to the runtime engine.

VISA RUNTIME ENGINE MAY NEED UPDATING: Consult [www.ni.com](http://www.ni.com) for the latest runtime engine. The VISA runtime engine is used to manage communication between the controller and the GUI. Again, updates to the Windows operating system may in turn require updates to the runtime engine.

FIREWALL MAY BE BLOCKING COMMUNICATION PORT: Please verify that the Windows or third-party firewall is not blocking access to the USB port.

USB CABLE NOT PROPERLY CONNECTED: Make sure the USB cable is properly inserted and in good working condition.

## CONTROLLER NOT PROVIDING THE EXPECTED OUTPUT POWER:

### COMMUNICATION

#### PROBLEM:

A communication problem is not allowing software to turn the output ON, or some other parameter is not set properly due to a communication problem.

#### HEAT SIDE MULTIPLIER:

If this is set to 0.00, the controller will not provide any output power when the controller goes into the heating mode. Set this value to something greater than zero to restore the controller's capability of heating.

#### COOL SIDE MULTIPLIER:

If this is set to 0.00, the controller will not provide any output power when the controller

is in the cooling mode. Set this value to something greater than zero to restore the controller's capability of cooling.

- LOW VOLTAGE:** Verify the controller is receiving at least 12 V from the power supply. The controller will shut off output power to protect the MOSFETs from damage if the input voltage drops below 11.2 V.
- OVER CURRENT:** Verify that the over-current level is set to an appropriate amount that is at least greater than the expected current draw of the thermoelectric device used with the controller. Check that a sufficient number of over-current restart attempts has been set.
- OUTPUT ON/OFF:** Verify that the controller has been set to turn on output power. You should also verify that the power supply is capable of providing the expected amount of current for the thermoelectric device at the voltage supplied by the power supply. If the power supply cannot provide sufficient current, it may be in an over-current condition.
- ALARM:** Verify that there are no alarm conditions and that the temperatures which trigger an alarm condition are set correctly. If you are certain no alarm condition exists, click the SEND LATCH CLEAR button.
- INTERLOCK:** Verify that the interlock is not forcing the output to off.
- INCORRECT POWER SUPPLY:** Using a power supply with a current output capability that is too low for the load will cause the power supply to shut down. Verify with a voltmeter that the power supply is not repeatedly shutting down and then restarting. The green LED on the controller may still flash if the controller intermittently receives sufficient operating voltage.
- CONTROLLER IN RAMP SOAK MODE:** From the keypad, select RUN PROGRAM > NO (TC-720 only), or from the GUI select PID control mode.

#### SYSTEM TEMPERATURE INCREASES WHEN COOLING EXPECTED:

**INSUFFICIENT HEAT SINK:** The thermoelectric (Peltier) elements do not have a sufficient heat sink, and input power heats entire system. In such a case, there is usually some initial reduction in temperature when power to the thermoelectric device is first turned on, but this is soon followed by a gradual heating of the system.

**OUTPUT POLARITY REVERSED:** Ensure the wire polarity is correct per schematic, and ensure proper control mode is selected. Ensure wire attachment (polarity) to the cooling device is correct. For thermoelectric (Peltier) modules, review the "*Thermoelectric Module Mounting (TEM) Mounting Procedure*", available from [www.tetech.com](http://www.tetech.com), and verify physical orientation of the cold side module within the system. For TE Technology standard cooling assemblies, verify wires are attached to proper positions on terminal strip (see section 1.4).

#### SYSTEM TEMPERATURE DOES NOT RESPOND AS EXPECTED:

**CONTROL TYPE IMPROPERLY SET:** Set CONTROL TYPE to PID control if you want the temperature controller to adjust the output power based on the actual temperature and the set temperature. Set CONTROL TYPE to COMPUTER CONTROL if you want to use an external computer to adjust the power output manually. See Section 2.3.

IMPROPER

SENSOR TYPE:

Verify an NTC thermistor is being used and its Resistance-versus-Temperature (R-T) curve is one that is supported by the controller. Verify the proper SENSOR TYPE has been selected. Alternatively, you will need to use a user-defined sensor.

## TC-720 Electrical Connections

**JP7: (PIN 1 IS CLOSEST TO CORNER OF CIRCUIT BOARD)**

PIN 1: TE DEVICE (+)

PIN 2: TE DEVICE (-)

PIN 3: main power supply, V (-)

PIN 4: main power supply, V (+), 36.0 V maximum (hard limit, do not exceed!)

**JP2: (PIN 1 IS CLOSEST TO USB CONNECTOR)**

PIN 1: CONTROL SENSOR (+)

PIN 2: CONTROL SENSOR (-)

PIN 3: SECONDARY SENSOR (-)

PIN 4: SECONDARY SENSOR (+)

PIN 5: ANALOG OUTPUT, (0 – 10) VDC

PIN 6: CONTROLLER INTERLOCK (enable by shorting to circuit ground when using interlock feature)

PIN 7: CIRCUIT GROUND

PIN 8: ALARM 1 SINK (OPEN DRAIN) 36 V maximum, 2 A maximum

PIN 9: LOGIC SUPPLY V (+) INPUT (>12 V, ≤36 V, 0.15 A minimum)

PIN 10: ALARM 2 SINK (OPEN DRAIN) 36 V maximum, 2 A maximum

USB connection: Type B female connector

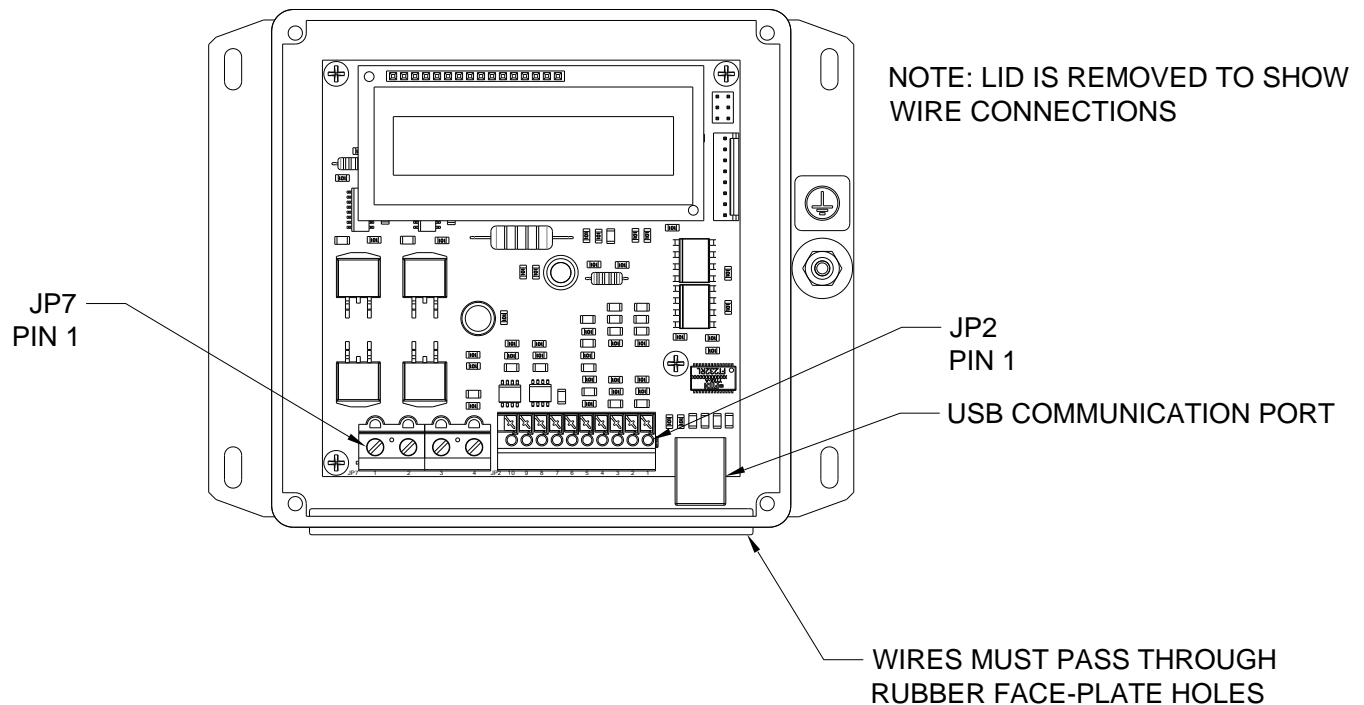

# TC-720 Mechanical Package Drawing

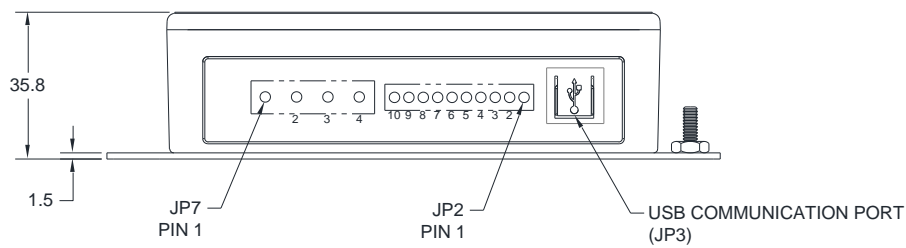
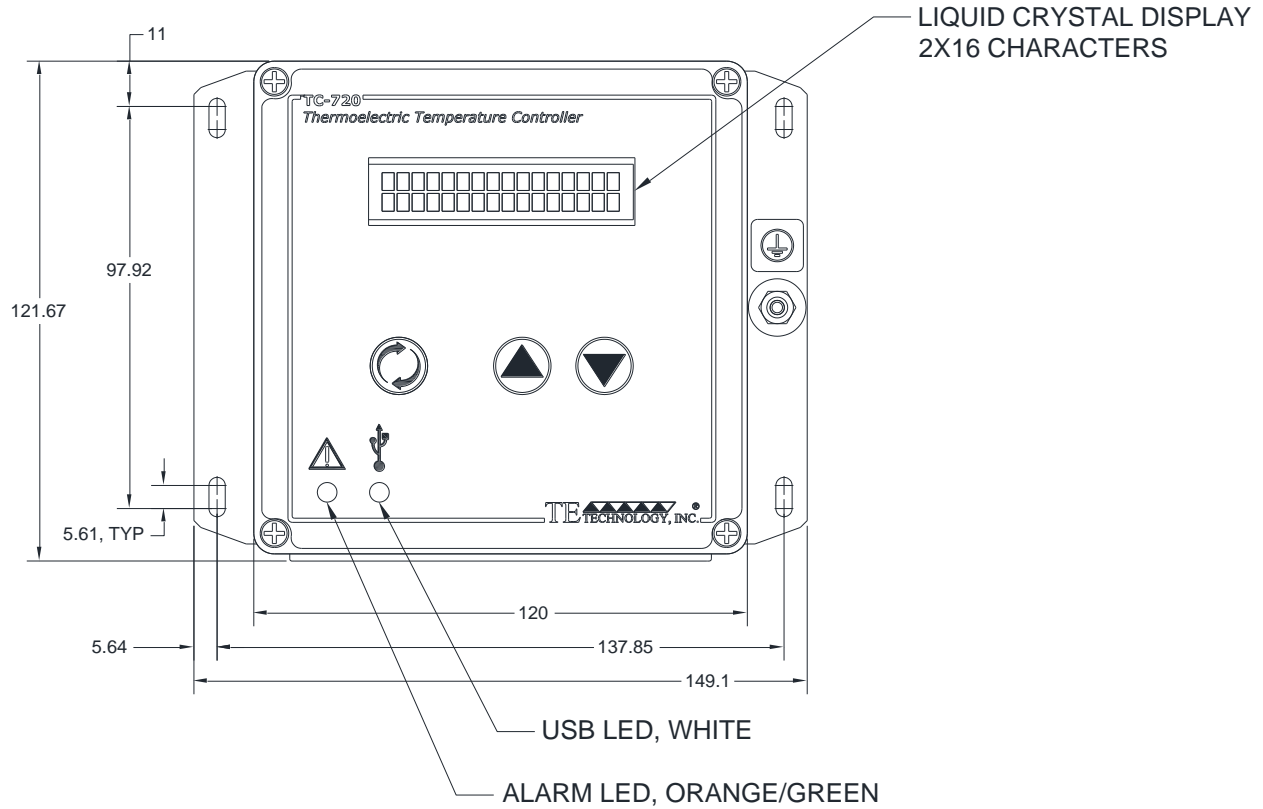

NOTE: All dimensions are in millimeters



# TC-720 OEM Mechanical Package Drawing

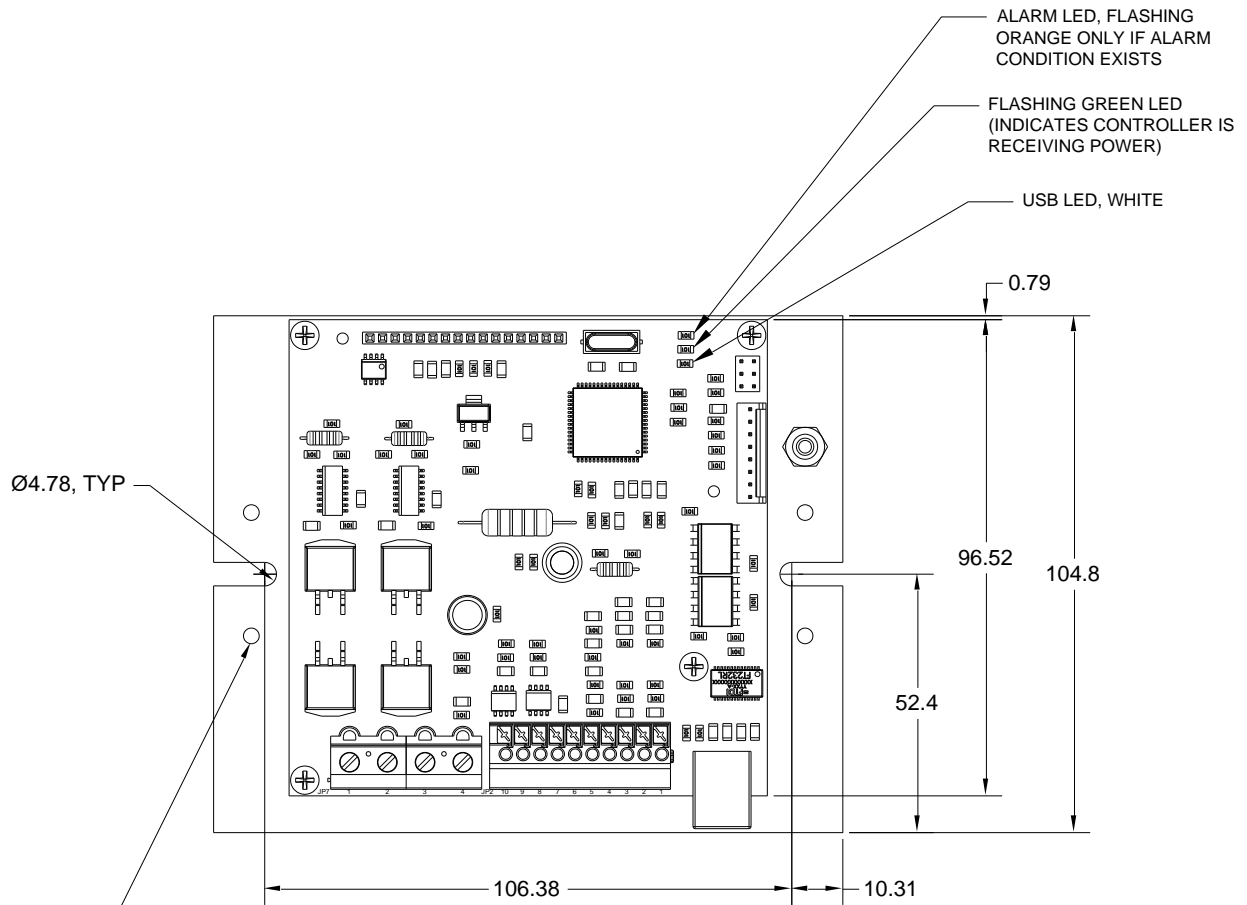

4X HOLES FOR DIN RAIL ADAPTOR  
**OPTIONAL ADDITIONS**  
 DIN RAIL ADAPTOR: PHOENIX CONTACT PART NUMBER 1201578  
 DIN RAIL ADAPTOR SCREWS: 4X M3 SELF TAPPING  
 DIN RAIL: USER SPECIFIED

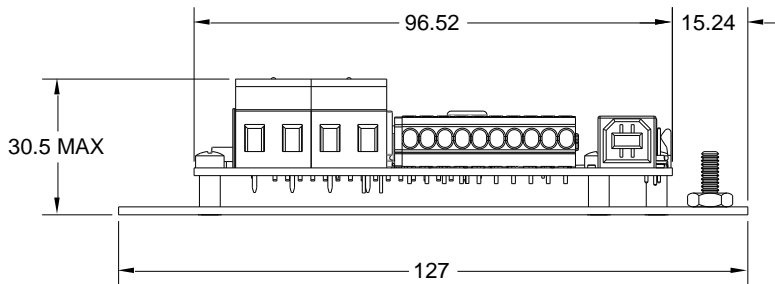

**NOTE:** All dimensions are in mm

### APPENDIX A-Thermistors Available for TC-720

Note: All dimensions in millimeters. Most standard thermistors have TS-67 (15 k-ohms) temperature-resistance curves. See [www.tetech.com](http://www.tetech.com) for additional styles.

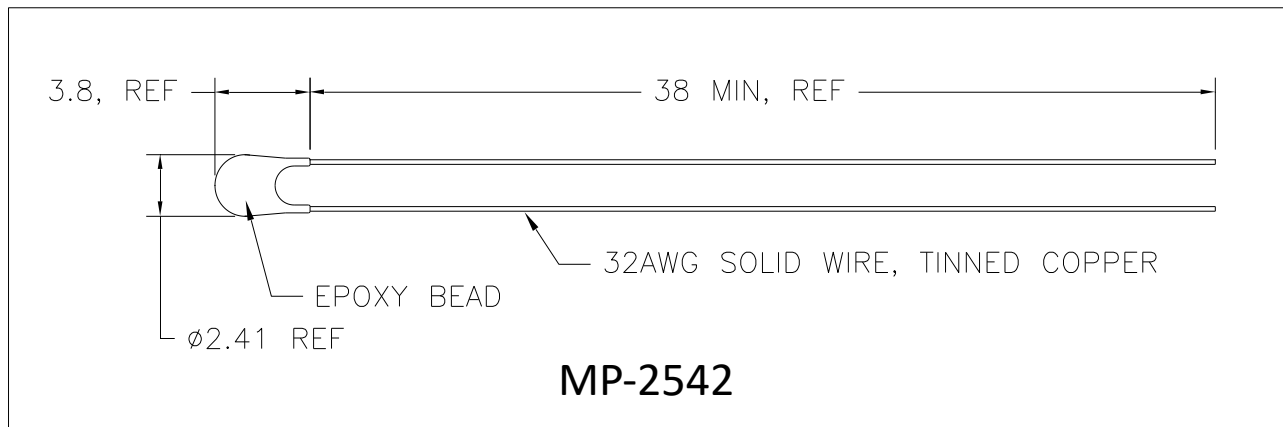
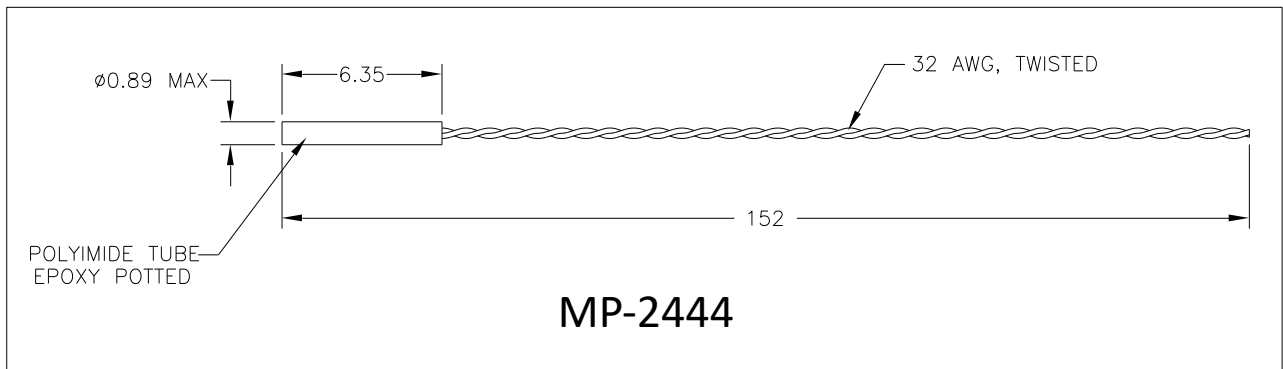
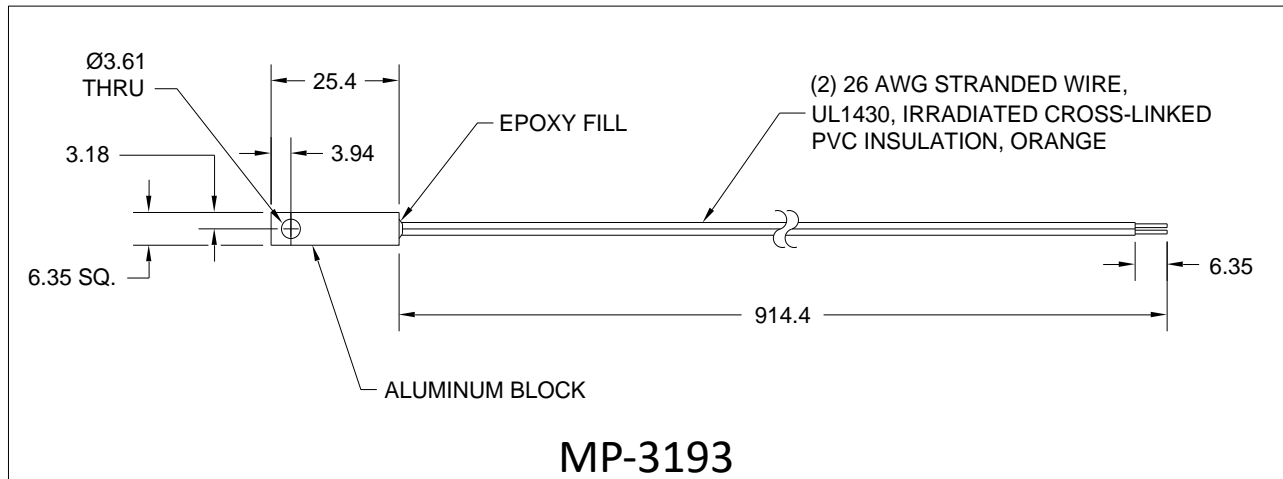

**TS-67 Temperature (°C) versus Resistance (ohms) Data  
For MP-3193, MP-2444, MP-2542, and MP-2996 (not pictured) 15 kΩ Thermistors**

-20	146735.0	1	46709.0	22	17136.0	43	7075.0	64	3227.0	85	1601.0
-19	138447.0	2	44397.0	23	16388.0	44	6801.0	65	3115.0	86	1551.0
-18	130677.0	3	42213.0	24	15676.0	45	6539.0	66	3008.0	87	1503.0
-17	123390.0	4	40150.0	25	15000.0	46	6289.0	67	2905.0	88	1457.0
-16	116554.0	5	38199.0	26	14356.0	47	6049.0	68	2806.0	89	1412.0
-15	110138.0	6	36354.0	27	13744.0	48	5820.0	69	2711.0	90	1369.0
-14	104113.0	7	34608.0	28	13161.0	49	5600.0	70	2620.0	91	1328.0
-13	98454.0	8	32957.0	29	12606.0	50	5391.0	71	2532.0	92	1288.0
-12	93137.0	9	31394.0	30	12078.0	51	5190.0	72	2448.0	93	1250.0
-11	88138.0	10	29914.0	31	11574.0	52	4997.0	73	2367.0	94	1212.0
-10	83438.0	11	28512.0	32	11095.0	53	4813.0	74	2288.0	95	1176.0
-9	79016.0	12	27183.0	33	10637.0	54	4637.0	75	2213.0	96	1142.0
-8	74855.0	13	25925.0	34	10202.0	55	4467.0	76	2141.0	97	1108.0
-7	70938.0	14	24731.0	35	9786.0	56	4305.0	77	2072.0	98	1076.0
-6	67249.0	15	23600.0	36	9389.0	57	4150.0	78	2005.0	99	1045.0
-5	63773.0	16	22526.0	37	9011.0	58	4001.0	79	1940.0	100	1014.0
-4	60498.0	17	21508.0	38	8650.0	59	3858.0	80	1878.0		
-3	57410.0	18	20541.0	39	8306.0	60	3721.0	81	1818.0		
-2	54498.0	19	19623.0	40	7976.0	61	3590.0	82	1761.0		
-1	51750.0	20	18751.0	41	7662.0	62	3464.0	83	1705.0		
0	49157.0	21	17923.0	42	7362.0	63	3343.0	84	1652.0		

Note: Tolerance for standard thermistors is  $\pm 650 \Omega$ , corresponding to  $\pm 1 \text{ }^\circ\text{C}$  over a  $0 \text{ }^\circ\text{C}$  to  $100 \text{ }^\circ\text{C}$  range.

**TS-141 Temperature (°C) versus Resistance (ohms) Data  
For MP-3176 5 kΩ Thermistors**

-60.0	701030.0	-30.0	88520.1	0.0	16330.0	30.0	4028.1	60.0	1244.0	90.0	458.2
-59.0	649576.4	-29.0	83208.0	1.0	15519.3	31.0	3860.6	61.0	1200.1	91.0	444.3
-58.0	602226.0	-28.0	78247.1	2.0	14753.6	32.0	3700.9	62.0	1158.0	92.0	431.0
-57.0	558627.3	-27.0	73612.3	3.0	14030.1	33.0	3548.8	63.0	1117.6	93.0	418.1
-56.0	518461.3	-26.0	69280.3	4.0	13346.2	34.0	3403.7	64.0	1078.8	94.0	405.6
-55.0	481437.4	-25.0	65229.5	5.0	12699.6	35.0	3265.3	65.0	1041.6	95.0	393.6
-54.0	447291.6	-24.0	61440.2	6.0	12088.0	36.0	3133.3	66.0	1005.8	96.0	382.0
-53.0	415783.4	-23.0	57893.9	7.0	11509.4	37.0	3007.4	67.0	971.4	97.0	370.8
-52.0	386693.4	-22.0	54573.8	8.0	10961.8	38.0	2887.1	68.0	938.4	98.0	359.9
-51.0	359822.2	-21.0	51464.2	9.0	10443.4	39.0	2772.4	69.0	906.7	99.0	349.5
-50.0	334987.4	-20.0	48550.5	10.0	9952.4	40.0	2662.8	70.0	876.2	100.0	339.3
-49.0	312023.0	-19.0	45819.2	11.0	9487.3	41.0	2558.1	71.0	846.9	101.0	329.6
-48.0	290777.1	-18.0	43258.1	12.0	9046.6	42.0	2458.1	72.0	818.7	102.0	320.1
-47.0	271111.3	-17.0	40855.4	13.0	8628.9	43.0	2362.5	73.0	791.6	103.0	311.0
-46.0	252898.7	-16.0	38600.6	14.0	8232.8	44.0	2271.2	74.0	765.5	104.0	302.2
-45.0	236023.7	-15.0	36483.7	15.0	7857.1	45.0	2183.9	75.0	740.4	105.0	293.6
-44.0	220380.2	-14.0	34495.5	16.0	7500.6	46.0	2100.4	76.0	716.2	106.0	285.4
-43.0	205871.3	-13.0	32627.5	17.0	7162.4	47.0	2020.5	77.0	693.0	107.0	277.4
-42.0	192408.1	-12.0	30871.8	18.0	6841.2	48.0	1944.1	78.0	670.6	108.0	269.7
-41.0	179909.1	-11.0	29220.9	19.0	6536.3	49.0	1870.9	79.0	649.1	109.0	262.2
-40.0	168299.9	-10.0	27668.1	20.0	6246.7	50.0	1800.9	80.0	628.3	110.0	255.0
-39.0	157511.9	-9.0	26207.0	21.0	5971.5	51.0	1733.9	81.0	608.4		
-38.0	147482.4	-8.0	24831.7	22.0	5710.0	52.0	1669.8	82.0	589.1		
-37.0	138153.6	-7.0	23536.6	23.0	5461.3	53.0	1608.3	83.0	570.6		
-36.0	129472.6	-6.0	22316.7	24.0	5224.9	54.0	1549.4	84.0	552.7		
-35.0	121390.7	-5.0	21167.2	25.0	5000.0	55.0	1493.0	85.0	535.5		
-34.0	113863.1	-4.0	20083.6	26.0	4786.0	56.0	1438.9	86.0	518.9		
-33.0	106848.7	-3.0	19061.8	27.0	4582.4	57.0	1387.1	87.0	502.9		
-32.0	100309.5	-2.0	18098.0	28.0	4388.5	58.0	1337.4	88.0	487.4		
-31.0	94210.7	-1.0	17188.5	29.0	4203.9	59.0	1289.7	89.0	472.6		

**TS-91 Temperature (°C) versus Resistance (ohms) Data  
For 10 kΩ Type 1 Thermistors**

-20	97120.0	1	31040.0	23	10920.0	44	4544.0	65	2082.0
-19	91660.0	2	29500.0	24	10450.0	45	4368.0	66	2012.0
-18	86540.0	3	28060.0	25	10000.0	46	4202.0	67	1942.0
-17	81720.0	4	26680.0	26	9574.0	47	4042.0	68	1876.0
-16	77220.0	5	25400.0	27	9166.0	48	3888.0	69	1813.0
-15	72980.0	6	24180.0	28	8778.0	49	3742.0	70	1751.0
-14	69000.0	7	23020.0	29	8408.0	50	3602.0	71	1693.0
-13	65260.0	8	21920.0	30	8058.0	51	3468.0	72	1637.0
-12	61760.0	9	20880.0	31	7722.0	52	3340.0	73	1582.0
-11	58460.0	10	19900.0	32	7404.0	53	3216.0	74	1530.0
-10	55340.0	11	18970.0	33	7098.0	54	3098.0	75	1480.0
-9	52420.0	12	18090.0	34	6808.0	55	2986.0	76	1432.0
-8	49660.0	13	17260.0	35	6532.0	56	2878.0	77	1385.0
-7	47080.0	14	16460.0	36	6268.0	57	2774.0	78	1341.0
-6	44640.0	15	15710.0	37	6016.0	58	2674.0	79	1298.0
-5	42340.0	16	15000.0	38	5776.0	59	2580.0	80	1256.0
-4	40160.0	17	14320.0	39	5546.0	60	2488.0	81	1216.0
-3	38120.0	18	13680.0	40	5326.0	61	2400.0	82	1178.0
-2	36200.0	19	13070.0	41	5118.0	62	2316.0	83	1141.0
-1	34380.0	20	12490.0	42	4918.0	63	2234.0	84	1105.0
0	32660.0	21	11940.0	43	4726.0	64	2158.0	85	1071.0

**TP-53 Temperature (°C) versus Resistance (ohms) Data  
For 10 kΩ Type 2 Thermistors**

-15	61020.0	6	22430.0	27	9227.0	48	4179.0	69	2055.0
-14	58010.0	7	21450.0	28	8867.0	49	4033.0	70	1990.0
-13	55170.0	8	20520.0	29	8523.0	50	3893.0	71	1928.0
-12	52480.0	9	19630.0	30	8194.0	51	3758.0	72	1868.0
-11	49940.0	10	18790.0	31	7880.0	52	3629.0	73	1810.0
-10	47540.0	11	17980.0	32	7579.0	53	3504.0	74	1754.0
-9	45270.0	12	17220.0	33	7291.0	54	3385.0	75	1700.0
-8	43110.0	13	16490.0	34	7016.0	55	3270.0	76	1648.0
-7	41070.0	14	15790.0	35	6752.0	56	3160.0	77	1598.0
-6	39140.0	15	15130.0	36	6500.0	57	3054.0	78	1549.0
-5	37310.0	16	14500.0	37	6258.0	58	2952.0	79	1503.0
-4	35570.0	17	13900.0	38	6026.0	59	2854.0	80	1458.0
-3	33930.0	18	13330.0	39	5805.0	60	2760.0		
-2	32370.0	19	12790.0	40	5592.0	61	2669.0		
-1	30890.0	20	12260.0	41	5389.0	62	2582.0		
0	29490.0	21	11770.0	42	5193.0	63	2497.0		
1	28150.0	22	11290.0	43	5006.0	64	2417.0		
2	26890.0	23	10840.0	44	4827.0	65	2339.0		
3	25690.0	24	10410.0	45	4655.0	66	2264.0		
4	24550.0	25	10000.0	46	4489.0	67	2191.0		
5	23460.0	26	9605.0	47	4331.0	68	2122.0		

**TS-104 Temperature (°C) versus Resistance (ohms) Data  
For MP-3022 50 kΩ Thermistors**

0	163300.0	26	47870.0	52	16700.0	78	6705.0	104	3025.0	130	1503.0
1	155200.0	27	45830.0	53	16080.0	79	6490.0	105	2940.0	131	1465.0
2	147500.0	28	43890.0	54	15490.0	80	6280.0	106	2857.0	132	1429.0
3	140300.0	29	42040.0	55	14930.0	81	6080.0	107	2778.0	133	1394.0
4	133400.0	30	40290.0	56	14390.0	82	5890.0	108	2701.0	134	1360.0
5	127000.0	31	38610.0	57	13870.0	83	5705.0	109	2626.0	135	1326.0
6	120900.0	32	37020.0	58	13370.0	84	5525.0	110	2554.0	136	1294.0
7	115100.0	33	35490.0	59	12900.0	85	5355.0	111	2484.0	137	1263.0
8	109600.0	34	34040.0	60	12400.0	86	5190.0	112	2416.0	138	1232.0
9	104400.0	35	32660.0	61	12000.0	87	5030.0	113	2351.0	139	1203.0
10	99500.0	36	31340.0	62	11580.0	88	4875.0	114	2287.0	140	1174.0
11	94850.0	37	30080.0	63	11170.0	89	4726.0	115	2226.0	141	1146.0
12	90450.0	38	28880.0	64	10790.0	90	4582.0	116	2167.0	142	1119.0
13	86300.0	39	27730.0	65	10410.0	91	4444.0	117	2109.0	143	1092.0
14	82300.0	40	26630.0	66	10060.0	92	4310.0	118	2053.0	144	1067.0
15	78550.0	41	25590.0	67	9710.0	93	4182.0	119	1999.0	145	1042.0
16	75000.0	42	24590.0	68	9380.0	94	4057.0	120	1947.0	146	1018.0
17	71600.0	43	23630.0	69	9065.0	95	3937.0	121	1896.0	147	994.0
18	68400.0	44	22720.0	70	8755.0	96	3821.0	122	1847.0	148	971.0
19	65350.0	45	21840.0	71	8465.0	97	3709.0	123	1799.0	149	949.0
20	62450.0	46	21010.0	72	8185.0	98	3601.0	124	1753.0	150	927.0
21	59700.0	47	20210.0	73	7910.0	99	3497.0	125	1708.0		
22	57100.0	48	19440.0	74	7650.0	100	3396.0	126	1664.0		
23	54600.0	49	18710.0	75	7400.0	101	3298.0	127	1622.0		
24	52250.0	50	18010.0	76	7160.0	102	3204.0	128	1581.0		
25	50000.0	51	17340.0	77	6925.0	103	3113.0	129	1541.0		

**TS-165 Temperature (°C) versus Resistance (ohms) Data  
For 230 kΩ Thermistors**

25	231438.2	71	35099.7	117	7792.1	163	2289.3	209	830.8
26	221032.6	72	33847.4	118	7567.0	164	2234.8	210	814.3
27	211147.1	73	32645.5	119	7349.4	165	2181.9	211	798.1
28	201753.2	74	31491.9	120	7139.0	166	2130.4	212	782.4
29	192824.2	75	30384.2	121	6935.4	167	2080.3	213	767.0
30	184334.8	76	29320.7	122	6738.6	168	2031.6	214	752.0
31	176261.5	77	28299.2	123	6548.2	169	1984.3	215	737.3
32	168581.8	78	27318.1	124	6363.9	170	1938.2	216	723.0
33	161274.8	79	26375.3	125	6185.6	171	1893.4	217	709.0
34	154320.7	80	25469.4	126	6013.1	172	1849.8	218	695.3
35	147700.8	81	24598.7	127	5846.1	173	1807.3	219	681.9
36	141397.6	82	23761.8	128	5684.4	174	1766.0	220	668.9
37	135394.3	83	22987.1	129	5527.9	175	1725.8	221	656.1
38	129675.4	84	22183.3	130	5376.3	176	1686.7	222	643.6
39	124226.1	85	21439.1	131	5229.6	177	1648.6	223	631.4
40	119032.5	86	20723.2	132	5087.4	178	1611.5	224	619.5
41	114081.4	87	20034.4	133	4949.7	179	1575.4	225	607.9
42	109360.3	88	19371.6	134	4816.3	180	1540.3	226	596.5
43	104857.6	89	18733.7	135	4687.1	181	1506.1	227	585.3
44	100562.2	90	18119.7	136	4561.8	182	1472.7	228	574.4
45	96463.6	91	17528.5	137	4440.4	183	1440.2	229	563.8
46	92551.8	92	16959.3	138	4322.8	184	1408.6	230	553.4
47	88817.6	93	16411.1	139	4208.7	185	1377.8	231	543.2
48	85252.0	94	15883.0	140	4098.7	186	1347.8	232	533.2
49	81846.8	95	15374.3	141	3991.0	187	1318.5	233	523.5
50	78593.9	96	14884.1	142	3887.0	188	1290.0	234	514.0
51	75485.9	97	14411.7	143	3786.2	189	1262.2	235	504.7
52	72515.7	98	13956.4	144	3688.3	190	1235.1	236	495.5
53	69676.6	99	13517.5	145	3593.5	191	1208.7	237	486.6
54	66962.1	100	13094.3	146	3501.4	192	1183.0	238	477.9
55	64366.4	101	12686.2	147	3412.1	193	1157.9	239	469.3
56	61883.6	102	12292.7	148	3325.4	194	1133.4	240	461.0
57	59508.3	103	11913.0	149	3241.3	195	1109.6	241	452.8
58	57235.5	104	11546.8	150	3159.6	196	1086.3	242	444.8
59	55060.2	105	11193.4	151	3080.3	197	1063.6	243	437.0
60	52977.8	106	10852.3	152	3003.4	198	1041.5	244	429.3
61	50984.1	107	10523.1	153	2928.6	199	1019.9	245	421.8
62	49074.7	108	10205.4	154	2856.1	200	998.8	246	414.4
63	47245.8	109	9898.6	155	2785.6	201	978.3	247	407.2
64	45493.6	110	9602.3	156	2717.1	202	958.2	248	400.2
65	43814.6	111	9316.3	157	2650.6	203	938.7	249	393.5
66	42205.4	112	9039.9	158	2586.0	204	919.6	250	386.5
67	40662.8	113	8773.0	159	2523.2	205	901.0		
68	39183.7	114	8515.0	160	2462.2	206	882.8		
69	37765.4	115	8265.8	161	2402.9	207	865.0		
70	36404.9	116	8024.9	162	2345.3	208	847.7		

## Appendix B - USB Communications

### I. USB Communications Parameters

- A. Baud Rate 230400
- B. No Parity
- C. 1 Start Bit 1 Stop Bit

### II. Definitions:

All numeric values are in hexadecimal format. Use lowercase ASCII characters.

Note: Where applicable, the base of a number is indicated by its subscript. So,  $20_{10}$  is the number 20 in decimal (base 10) format, and it converts to  $14_{16}$  in hexadecimal (base 16) format.

(stx) Start of text character (\*)  $2a_{16}$ .

(etx) End of text character (carriage return) or  $0d_{16}$ .

(ack) Acknowledge character (^)  $5e_{16}$ .

CC Command characters are ASCII characters from 0 through 9 or a through f.

DDDD This is the ASCII representation of the hexadecimal return or send value. Negative numbers are represented by the hex 2's complement of the number (16-bit word size):

$$1_{10} = 0001_{16}$$

$$-1_{10} = ffff_{16}$$

SS The 8 bit (modulo 256) checksum of characters sent/from the controlling computer. This is represented as two ASCII hex characters. The checksum excludes the characters (stx), SS, and (etx). The TC-720 sums (in an 8-bit register) the ASCII values of the characters sent to/from the controlling computer. Any overflow is truncated, leaving the 8-bit (modulo 256) checksum. When the controller is receiving data, this number (as represented by two hex characters) is compared to the two ASCII character hex checksum sent by the controlling computer. The TC-720 will respond as shown below depending on whether or not the checksums match. When the controlling computer is receiving data the checksum sent by the controller can be used to make sure the data has not been received with an error. *Remember, when finding the ASCII value for a hex number (a, b, c, d, e, and f) be sure to use lower case letters.*

To write a command to a controller, the controlling computer must send the following ASCII characters:

(stx)CCDDDDSS(etx)

If the temperature controller receives the command and the checksum is correct, the temperature controller will respond by sending back the "send value" and the checksum of those four ASCII data characters, DDDD:

(stx)DDDDSS (ack)

To query a controller, there is no send value so the controlling computer only needs to send the ASCII command characters with the "D"s filled with zeros:

(stx)CC0000SS(etx)

If the checksum for a query is correct the temperature controller will respond by sending back a "return value" and then SS, which is the checksum of the four return value (DDDD) characters:

(stx)DDDDSS(ack)

If the checksum for a command or query is not correct the temperature controller will respond with four upper case X's and then 60, which is the checksum of these four X's:

(stx)XXXX60 (ack)



### III. Examples:

A) Send the set temperature of 10.00 to the controller.

1. The control command, CC, for "FIXED DESIRED CONTROL SETTING" is 1c.
2. Multiply the desired set-point temperature by  $100_{10}$  ( $10.00_{10} \times 100_{10} = 1000_{10}$ ).
3. Convert  $1000_{10}$  decimal to hexadecimal ( $3e8_{16}$ ) and add on leading zeros to make the four-character send value DDDD (03e8).
4. Compute the checksum (SS) by adding the hexadecimal values of the following ASCII characters: 1, c, 0, 3, e, and 8:

<u>ASCII Character:</u>	<u>Hexadecimal Value:</u>
1	31
c	63
0	30
3	33
e	65
<u>8</u>	<u>38</u>
<b>Sum</b>	<b>194<sub>16</sub></b>

The 8-bit checksum is the 8 least significant binary bits of the sum, represented as 94 in hexadecimal.

5. Combining all of these characters in one string we send: (stx)1c03e894(etx).
6. If the temperature controller receives the command and the checksum is correct, it will send back: (stx)03e800(ack). If the checksum is not correct the temperature controller will send back: (stx)XXXX60(ack).

B) Send the low set range of 10 to the controller.

1. The control command, CC, for "LOW SET RANGE" is 22.
2. Convert  $10_{10}$  decimal to hexadecimal ( $a_{16}$ ) and add on leading zeros to make the four-character send value DDDD (000a).
3. Compute the checksum (SS) by adding the hexadecimal values of the following ASCII characters: 2, 2, d, d, 0, 0, 0, and a:

<u>ASCII Character:</u>	<u>Hexadecimal Value:</u>
2	32
2	32
0	30
0	30
0	30
<u>a</u>	<u>61</u>
<b>Sum</b>	<b>155<sub>16</sub></b>

The 8-bit checksum is the 8 least significant binary bits of the sum, represented as 55 in hexadecimal.

4. Combining all of these characters in one string we send: (stx)22000a55(etx).
5. If the temperature controller receives the command and the checksum is correct, it will send back: (stx)000a00(ack). If the checksum is not correct the temperature controller will send back: (stx)XXXX60(ack).

C) Send the set temperature of -1.50 °C.

1. The controller command, CC, is 1c.
2. Multiply the desired set-point temperature by  $100_{10}$  ( $-1.50 \times 100 = -150$ ).
3. Convert  $-150_{10}$  to hexadecimal by taking the two's complement of the number. (This can be easily done by using the formula  $2^n - N$ , where  $n$  is the word-bit size and  $N$  is the absolute value of the number being converted.) Hence, you have  $2^{16} - 150 = 65386_{10}$ . This value then converts to ff6a<sub>16</sub>.
4. Compute the checksum (SS) by adding the hexadecimal ASCII values of the following characters: 1, c, f, f, 6, a,:

<u>ASCII Character:</u>	<u>Hexadecimal Value:</u>
1	31
c	63
f	66
f	66
6	36
a	<u>61</u>
<b>Sum</b>	<b>1f7<sub>16</sub></b>

The 8-bit checksum is the 8 least significant binary bits of the sum, represented as f7 in hexadecimal.

- Combining all of these characters in one string we send: (stx)1cff6af7(etx).
- If the temperature controller receives the command and the checksum is correct, it will send back: (stx)ff6a63(ack). If the checksum is not correct the temperature controller will send back: (stx)XXXX60(ack).

D) Read the actual temperature of the control thermistor.

- Let us assume the actual temperature is 2.50 °C.
- The control command, CC, for "INPUT1" sensor temperature is 01.
- There is no send value, so we calculate the checksum (SS) by adding the ASCII values of the characters 0, 1, 0, 0, 0, 0:

<u>ASCII Character:</u>	<u>Hexadecimal Value:</u>
0	30
1	31
0	30
0	30
0	30
<u>0</u>	<u>30</u>
<b>Sum</b>	<b>121<sub>16</sub></b>

The 8-bit checksum is the 8 least significant binary bits of the sum, represented as 21 in hexadecimal.

- Combining the characters in one string we send: (stx)01000021(etx).
- If the temperature controller receives the command and the checksum is correct, it will send back: (stx)00fa27(ack). The "27" at the end of the string is the checksum of "00fa". The value 00fa<sub>16</sub> converts to 250<sub>10</sub>. This number, when divided by 100, is 2.50--the temperature in °C. As in the other examples, if the controller did not calculate the correct checksum from the query it would send back: (stx)XXXX60(ack).

#### IV. Serial Commands

1. MODEL CODE

Write Command: NA

Read Command: 00

Interpret: 9625 returned. (This is an internal code to ensure the TC-720 software is communicating with an actual TC-720.)

2. INPUT1 (reads the value sensed by the primary sensor)

Write Command: NA

Read Command: 01

Interpret: Convert the returned hexadecimal value to decimal, and then divide by 100<sub>10</sub>.

3. POWER OUTPUT

Write Command: NA

Read Command: 02

Interpret: Convert the returned hexadecimal value to decimal. 511<sub>10</sub> represent 100% output (heating) and -511<sub>10</sub> represent -100% output (cooling)

4. INPUT2 (reads the value sensed by the secondary sensor)

Write Command: NA

Read Command: 04

Interpret: Convert the returned hexadecimal value to decimal, and then divide by 100<sub>10</sub>.

5. ALARM STATUS

Write Command: NA

Read Command: 03

Interpret: Convert the hexadecimal number to binary and interpret bits as follows:

All zeros == means no alarms.

Bit 0==1 means HIGH ALARM1.

Bit 1==1 means LOW ALARM1.

Bit 2==1 means HIGH ALARM2.

Bit 3==1 means LOW ALARM2.

Bit 4==1 means OPEN INPUT1.

Bit 5==1 means OPEN INPUT2.

Bit 6==1 means LOW INPUT VOLTAGE

Bit 7==1 means key was pressed to store value

Bit 8==1 means OVER CURRENT DETECTED

For example, suppose the returned value is 0009<sub>16</sub>. This converts to 001001<sub>2</sub>, which means that there is a low alarm condition for the secondary sensor and a high alarm condition for the control sensor. "Bit 0" is the rightmost bit, or the least significant bit.

6. FIXED DESIRED CONTROL SETTING

Write Command: 1c

Read Command: 50

Interpret: To send a set temperature, multiply the decimal value by 100<sub>10</sub> and convert to hexadecimal. To read the set temperature, convert the returned hexadecimal value to decimal, and then divide by 100<sub>10</sub>.

7. PROPORTIONAL BANDWIDTH

Write Command: 1d

Read Command: 51

Interpret: proportional bandwidth in °C.

For writing, multiply the desired bandwidth by 100<sub>10</sub> then convert to hexadecimal. For reading, convert the returned hexadecimal to decimal, and then divide by 100<sub>10</sub>.

1.00<sub>10</sub> °C bandwidth would be 100<sub>10</sub>.

20.00<sub>10</sub> °C bandwidth would be 2000<sub>10</sub>.

8. INTEGRAL GAIN

Write Command: 1e

Read Command: 52

Interpret: integral gain in Repeats/minute

For writing, multiply the desired integral gain by 100<sub>10</sub> then convert to hexadecimal. For reading, convert to decimal then divide by 100<sub>10</sub>.

0.01 rep/min would be 1<sub>10</sub>.

1.00 rep/min would be 100<sub>10</sub>.

9. DERIVATIVE GAIN

Write Command: 1f

Read Command: 53

Interpret: derivative gain in minutes.

For writing, multiply desired integral gain by 100<sub>10</sub> then convert to hexadecimal. For reading, convert to decimal then divide by 100<sub>10</sub>.

0.01 min would be 1<sub>10</sub>.

1.00 min would be 100<sub>10</sub>.

10. ALARM1 TYPE

Write Command: 27

Read Command: 5b

Interpret: 0, no load effect; the controller will continue to provide output power  
1, load off on alarm; the controller will turn off output power

11. ALARM2 TYPE

Write Command: 2a

Read Command: 5e

Interpret: 0 no load effect; the controller will continue to provide output power  
1, load off on alarm; the controller will turn off output power

12. SENSOR1 CHOICE

Write Command: 20

Read Command: 54

Interpret: 0 == 5 kΩ thermistor  
1 == 10 kΩ thermistor, type 1 (TS-91)  
2 == 10 kΩ thermistor, type 2 (TP-53)  
3 == 15 kΩ thermistor  
4 == 50 kΩ thermistor  
5 == 230 kΩ thermistor  
6 == user defined table

13. SENSOR2 CHOICE

Write Command: 47

Read Command: 7c

Interpret:       0 == 5 kΩ thermistor  
                  1 == 10 kΩ thermistor, type 1 (TS-91)  
                  2 == 10 kΩ thermistor, type 2 (TP-53)  
                  3 == 15 kΩ thermistor  
                  4 == 50 kΩ thermistor  
                  5 == 230 kΩ thermistor  
                  6 == user defined table

14. CONTROLLER IDENTIFICATION

Write Command: 21

Read Command: 55

Interpret: range  $-32768_{10}$  to  $32767_{10}$

A number that can be programmed into the controller as an identifier

15. LOW SET RANGE

Write Command: 22

Read Command: 56

Interpret: This is used to set the lowest allowable temperature that the controller set point can be set to.

Note: Values must be whole numbers/integers. Do not represent number with decimal places.  $10_{10}$  °C is simply  $10_{10}$  or  $000a_{16}$ .

16. HIGH SET RANGE

Write Command: 23

Read Command: 57

Interpret: This is used to set the highest allowable temperature that the controller set point can be set to.

Note: Values must be whole numbers/integers. Do not represent number with decimal places.  $10_{10}$  °C is simply  $10_{10}$  or  $000a_{16}$ .

17. INPUT1 CONTROL SENSOR OFFSET

Write Command: 24

Read Command: 58

Interpret: Value to offset INPUT1 by in order to calibrate external sensor if desired.

18. LOW ALARM1 SETTING

Write Command: 25

Read Command: 59

Interpret: Temperature reference to compare against INPUT1 for low alarm output.

Note: Values must be whole numbers/integers. Do not represent number with decimal places.  $10_{10}$  °C is simply  $10_{10}$  or  $000a_{16}$ .

19. HIGH ALARM1 SETTING

Write Command: 26

Read Command: 5a

Interpret: Temperature reference to compare against INPUT1 for high alarm output.

Note: Values must be whole numbers/integers. Do not represent number with decimal places.  $10_{10}$  °C is simply  $10_{10}$  or  $000a_{16}$ .

20. LOW ALARM2 SETTING

Write Command: 28

Read Command: 5c

Interpret: Temperature reference to compare against INPUT2 for low alarm output.

Note: Values must be whole numbers/integers. Do not represent number with decimal places. 10<sub>10</sub> °C is simply 10<sub>10</sub> or 000a<sub>16</sub>.

21. HIGH ALARM2 SETTING

Write Command: 29

Read Command: 5d

Interpret: Temperature reference to compare against INPUT2 for high alarm output.

Note: Values must be whole numbers/integers. Do not represent number with decimal places. 10<sub>10</sub> °C is simply 10<sub>10</sub> or 000a<sub>16</sub>.

22. ALARM LATCH FUNCTION

Write Command: 2b

Read Command: 5f

Interpret:       0 == NO LATCHES  
                  1 == ALARM1 LATCH  
                  2 == ALARM 2 LATCH  
                  3 == ALARM 1&2 LATCH

23. ALARM1 DEADBAND

Write Command: 2d

Read Command: 61

Interpret: The span in temperature that the control sensor (INPUT1) must move before the ALARM1 output is toggled off. For writing, multiply the desired deadband by 100<sub>10</sub>, and then convert to hexadecimal. For reading, convert the hexadecimal value to decimal, and then divide by 100<sub>10</sub>.  
                  1.00<sub>10</sub> degree would be 100<sub>10</sub>.  
                  20.00<sub>10</sub> degree would be 2000<sub>10</sub>.

24. ALARM2 DEADBAND

Write Command: 2e

Read Command: 62

Interpret: The span in temperature that the secondary sensor (INPUT2) must move before the ALARM2 output is toggled off. For writing, multiply the desired deadband by 100<sub>10</sub>, and then convert to hexadecimal. For reading, convert the hexadecimal value to decimal, and then divide by 100<sub>10</sub>.  
                  1.00<sub>10</sub> degree would be 100<sub>10</sub>.  
                  20.00<sub>10</sub> degree would be 2000<sub>10</sub>.

25. SENSOR FOR ALARM2

Write Command: 3a

Read Command: 6e

Interpret:       0 == monitors INPUT2 for ALARM2  
                  1 == monitors INPUT1 for ALARM2

26. ANALOG OUTPUT MULTIPLIER

Write Command: 2f

Read Command: 63

Interpret:   For writing, multiply the desired analog output multiplier by 100<sub>10</sub>, and then convert to hexadecimal.  
              For reading, convert the hexadecimal value to decimal, and then divide by 100<sub>10</sub>. The allowable range is 0 to 1.00.

                  0.00 multiplier would be 0

                  0.50 multiplier would be 50<sub>10</sub>

                  1.00 multiplier would be 100<sub>10</sub>

27. LATCH CLEAR

Write Command: 75

Read Command: NA

Interpret: Send this command to reset alarm latches.

28. OUTPUT ENABLE

Write Command: 30

Read Command: 64

Interpret:       0 == OFF  
                  1 == ON

29. SOFTWARE REVISION

Write Command: NA

Read Command: 05

Interpret: Returns revision level of software

30. SET TEMPERATURE READ

Write Command: NA

Read Command: 06

Interpret: Convert the returned hexadecimal value to decimal, and then divide by 100<sub>10</sub>.

31. EEPROM WRITE ENABLE or DISABLE

Write Command: 31

Read Command: 65

Interpret:       0 == EEPROM write is disabled  
                  1 == EEPROM write is enabled

*Note: This function is always stored to EEPROM.*

Upon a power-up or reset condition the controller performs an initialization of all variables with write commands and transfers their last written state stored in non-volatile memory (EEPROM) to appropriately referenced static RAM locations. This action is performed so the controller can run at a quicker pace due to the slow access of EEPROM. When EEPROM is write enabled, all variables with write commands have mirror storage of their communicated value. When EEPROM write is disabled, variables with write commands are not stored except to the appropriate static RAM locations. With EEPROM writes disabled, you have the ability to change the run-time values and configuration while not affecting the desired power-up state. Alternatively, this will also alleviate a possible problem by minimizing the number of writes to any EEPROM location. (The maximum number of writes that can be made is 1,000,000.)

32. INPUT2 SECONDARY SENSOR OFFSET

Write Command: 32

Read Command: 66

Interpret: Value to offset INPUT2 by in order to calibrate sensor.

33. HEAT MULTIPLIER

Write Command: 34

Read Command: 68

Interpret: This multiplies the heater percentage of power to offset its effectiveness. Sending 0 will prevent the controller from applying any power when heating would otherwise be required. Sending 1.00 would allow the controller to provide full power for heating as required. To write, first multiply the desired value by 100<sub>10</sub>, and then convert to hexadecimal. When reading, convert the hexadecimal value to decimal, and then divide by 100<sub>10</sub>.

34. COOL MULTIPLIER

Write Command: 33

Read Command: 67

Interpret: This multiplies the cooling percentage of power to offset its effectiveness. Sending 0 will prevent the controller from applying any power when cooling would otherwise be required. Sending 1.00 would allow the controller to provide full power for cooling as required. To write, first multiply the desired value by 100<sub>10</sub>, and then convert to hexadecimal. When reading, convert the hexadecimal value to decimal, and then divide by 100<sub>10</sub>.

35. LCD VIEW ADJUST

Write Command: 35

Read Command: 69

Interpret: Allowable range 0 to 255<sub>10</sub>. When adjusting the contrast, disable EEPROM writes until the desired contrast is achieved. A lower number will provide higher contrast; a higher number will provide lower contrast.

36. TEMP2 DISPLAY

Write Command: 2c

Read Command: 60

Interpret:       0 == OFF  
                  1 == AUTOMATIC  
                  2 == ON

37. ALARM 1 FAN

Write Command: 36

Read Command: 6a

Interpret:       0 == alarm switched  
                  1 == fan control +  
                  2 == fan control –

38. HIGH PWM % FAN

Write Command: 37

Read Command: 6b

Interpret: Allowable range is 0 to 100<sub>10</sub>. This is the high fan PWM % in cooling mode when using fan speed control. HIGH PWM % FAN should always be greater than LOW PWM % FAN.



39. LOW PWM % FAN

Write Command: 38

Read Command: 6c

Interpret: Allowable range is 0 to 100<sub>10</sub>. This is the low fan PWM % in cooling mode when using fan speed control. LOW PWM % FAN should always be less than HIGH PWM % FAN.

40. FAN PWM % BOOST

Write Command: 39

Read Command: 6d

Interpret: Allowable range is 0 to 100<sub>10</sub>, this is the OUTPUT% at which the fan speed starts to increase from LOW PWM% to HIGH PWM%.

41. FAN HEAT MODE (when Output >0%)

Write Command: 3b

Read Command: 6f

Interpret:       0 == FAN OFF DURING HEAT  
                  1 == FAN AT LOW DURING HEAT  
                  2 == FAN ON DURING HEAT (This proportionally increases the fan speed in the heating mode. This is a beta feature and technical support is not available at this time.)

42. FAN DELAY TIMER COUNTS

Write Command: 3e

Read Command: 72

Interpret: Range 0 to 32768<sub>10</sub>; 1 count corresponds to 0.02 seconds

43. FAN PWM FREQUENCY

Write Command: 3c

Read Command: 70

Interpret:       PWM frequency used for fan speed control (consult fan manufacturer for suitable frequency).  
                  0 == 43,200 Hz  
                  1 == 5,400 Hz  
                  2 == 675 Hz  
                  3 == 169 Hz  
                  4 == 42 Hz

44. SET MODE

Write Command: 3d

Read Command: 71

Interpret:       0 == NORMAL SET  
                  1 == RAMP/SOAK SET MODE  
                  2 == PROPORTIONAL+DEAD BAND

45. RAMP/SOAK SEQUENCE START/STOP

Write Command: 08

Read Command: NA

Interpret:       Send 1 to start sequence  
                  Send 0 to abort sequence

46. RAMP/SOAK status  
 Write Command: NA  
 Read Command: 09  
 Interpret: Convert the returned hexadecimal value to binary and interpret the bits as follows:  
 All zeros means no sequence running.  
 Bit 0 == means sequence running.  
 Bit 1 == means SOAK stage.  
 Bit 2 == means RAMP stage.  
 For example, if a sequence is running during the ramp stage, the read command would return 0005<sub>16</sub>. This converts to 101<sub>2</sub> where Bit 0 (the rightmost bit) is set and Bit 2 is set.
47. SEQUENCE POINTER  
 Write Command: NA  
 Read Command: 0a  
 Interpret: Ramp/Soak sequence stage value 0 through 7
48. STAGE SOAK TEMPERATURES  
 Write Commands: a0 through a7  
 Read Commands: a8 through af  
 Interpret: To send a soak temperature, multiply the decimal value by 100<sub>10</sub> and convert to hexadecimal. To read the soak temperature, convert the returned hexadecimal value to decimal, and then divide by 100<sub>10</sub>.
49. STAGE RAMP TIME COUNTS  
 Write Commands: b0 through b7  
 Read Commands: b8 through bf  
 Interpret: Ramp Time counts
50. STAGE SOAK TIME COUNTS  
 Write Commands: c0 through c7  
 Read Commands: c8 through cf  
 Interpret: Soak Time counts
51. STAGE NUMBER OF REPEAT COUNTS  
 Write Commands: d0 through d7  
 Read Commands: d8 through df  
 Interpret: Repeat counts
52. STAGE REPEAT LOCATION  
 Write Commands: e0 through e7  
 Read Commands: e8 through ef  
 Interpret: Repeat Stage pointer values (0 no repeats) and 1 – 8. This Repeat Stage pointer value corresponds to the PROGRAM STEP number shown in the GUI. These are numbered from 1-8, whereas the *index values* are numbered from 0-7. Within the controller hardware this Repeat Stage pointer value is decremented by 1 to get the ARRAY INDEX number in the ramp soak array (provided it is not 0).
53. RAMP SOAK TIMER RUN METHOD  
 Write Command: f0  
 Read Command: f1  
 Interpret: 0 == Set Temp Only  
 1 == Wait for control temp

54. RAMP SOAK ALLOWABLE DELTA FROM SET FOR RAMP SOAK TIMER RUN

Write Command: f2

Read Command: f3

Interpret: Fixed temperature difference in degrees.

Allowable range is 1.00<sub>10</sub> to 20.00<sub>10</sub>. To send, multiply the decimal value by 100<sub>10</sub> and convert to hexadecimal. To read, convert the returned hexadecimal value to decimal, and then divide by 100<sub>10</sub>.

55. RAMP/SOAK INCREMENT COUNTER

Write Command: f4

Read Command: f5

Interpret: Basic increment counter for the Ramp/Soak timers. This value multiplied by .05 is the base time in seconds. For example, sending a value of 20 would set the base timer to 1.0 seconds (20 x 0.05 = 1.0). When using TE Technology's GUI, the base increment counter is set to 20 so that the time scale in the ramp / soak user interface program is accurate.

56. CONTROL TYPE

Write Command: 3f

Read Command: 73

Interpret: 0 == PID PWM MODE  
1 == MANUAL SETTING OF OUTPUT VALUE  
2 == PID ANALOG OUTPUT

57. MANUAL OUTPUT PWM COUNT

Write Command: 40

Read Command: 74

Interpret: Range -511<sub>10</sub> to 511<sub>10</sub>, corresponds to (-100% power output to +100% power output)

58. PROPORTIONAL + DEADBAND FULL HEAT SET

Write Command: 41

Read Command: 76

Interpret: To send the low set temperature, multiply the decimal value by 100<sub>10</sub> and convert to hexadecimal. To read the low set temperature, convert the returned hexadecimal value to decimal, and then divide by 100<sub>10</sub>.

If the INPUT1 sensor reaches this temperature, the controller will provide maximum heating output power.

59. PROPORTIONAL + DEADBAND START HEAT SET

Write Command: 42

Read Command: 77

Interpret: To send the low dead set temperature, multiply the decimal value by 100<sub>10</sub> and convert to hexadecimal. To read the low dead set temperature, convert the returned hexadecimal value to decimal, and then divide by 100<sub>10</sub>.

If the INPUT1 sensor is greater than the PROPORTIONAL + DEADBAND START HEAT SET temperature but less than the PROPORTIONAL + DEADBAND START COOL SET temperature, then the controller will not provide any output power for cooling or heating. If the INPUT1 sensor is less than the PROPORTIONAL + DEADBAND START HEAT SET temperature, the controller will proportionally increase the amount of heating output power.

60. PROPORTIONAL + DEADBAND START COOL SET

Write Command: 43

Read Command: 78

Interpret: To send the high dead set temperature, multiply the decimal value by  $100_{10}$  and convert to hexadecimal. To read the high dead set temperature, convert the returned hexadecimal value to decimal, and then divide by  $100_{10}$ .

If the INPUT1 sensor is greater than the PROPORTIONAL + DEADBAND START HEAT SET temperature but less than the PROPORTIONAL + DEADBAND START COOL SET temperature, then the controller will not provide any output power for cooling or heating. If the INPUT1 sensor is greater than the PROPORTIONAL + DEADBAND START COOL SET temperature, the controller will proportionally increase the amount of cooling output power.

61. PROPORTIONAL + DEADBAND FULL COOL SET

Write Command: 44

Read Command: 79

Interpret: To send the high set temperature, multiply the decimal value by  $100_{10}$  and convert to hexadecimal. To read the high set temperature, convert the returned hexadecimal value to decimal, and then divide by  $100_{10}$ .

If the INPUT1 sensor reaches this temperature, the controller will provide maximum cooling output power.

**User Defined Lookup Table**

This table, stored in EEPROM, is used to define a profile of the temperature of the sensor versus a reference voltage. The table consists of 129 integer pointers, ranging from 0 to 128. Pointer 0 corresponds to 0 volts; Pointer 128 corresponds to 5 V. The controller will linearly interpolate values between the indexed values with the remaining bits. This is a 16-bit signed number.

62. USER DEFINED LOOKUP TABLE POINTER

Write Command: 90

Read Command: NA

Interpret: Range 0 to  $128_{10}$ ; sets the index pointer for writing or reading a value.

63. USER DEFINED LOOKUP TABLE VALUE WRITING

Write Command: 91

Read Command: NA

Interpret: The USER DEFINED LOOKUP TABLE POINTER must be set first before using this command. The value for this location ranges from  $-32767_{10}$  to  $32768_{10}$ . This corresponds to a range  $-327.67\text{ }^{\circ}\text{C}$  to  $+327.68\text{ }^{\circ}\text{C}$ .

64. USER DEFINED LOOKUP TABLE VALUE READING

Write Command: NA

Read Command: 92

Interpret: Send the index value with the Read Command to receive back the indexed value.

Example: Send 0 with the 92 command to see the value at TABLE[0].

65. OUTPUT CURRENT COUNTS

Write Command: NA

Read Command: 07

Interpret: Output current reading in A/D counts; approximately  $15_{10}$  counts/amp.

66. OUTPUT CURRENT A/D COUNTS OVERCURRENT DETECT VALUE

Write Command: 45

Read Command: 7a

Interpret: Overcurrent compare value of above current counts (greater than or equal trips over current alarm).

67. OUTPUT OVER CURRENT RETRIES BEFORE SHUTDOWN

Write Command: 46

Read Command: 7b

Interpret: Amount of output retries during overcurrent condition allowed before output shutdown. 30000<sub>10</sub> value is constant retry.

68. SPARE (non-volatile) EEPROM MEMORY

Write Command: 80

Read Command: 81

Interpret: When writing, first use the USER DEFINED LOOKUP TABLE POINTER command to set the index.  
Read value by sending index with read command request.  
Valid index values are 0 through 9 (10 total locations). Valid values are 0 to 255<sub>10</sub>.

69. PROPORTIONAL BANDWIDTH RAMP/SOAK ARRAY INDEX

Write Command: 82

Read Command: NA

Interpret: Acceptable values range from 0 to 7. This is the index number is used to set which PROGRAM STEP the PROPORTIONAL BANDWIDTH RAMP/SOAK ARRAY VALUE will be written. (Reference PROGRAM STEP number in TE Technology's LabVIEW-based GUI, Ramp Soak programming). The index number + 1 = PROGRAM STEP number.

70. PROPORTIONAL BANDWIDTH RAMP/SOAK ARRAY VALUE

Write Command: 83

Read Command: 84

Interpret: When writing, first use the PROPORTIONALBANDWIDTH RAMP/SOAK ARRAY INDEX command to set the index value. Then use the write command to write the PROPORTIONAL BANDWIDTH RAMP/SOAK ARRAY VALUE.

When reading, just send the index value (0 to 7) with the Read Command to receive back the value at the indexed location.

71. INTEGRAL GAIN RAMP/SOAK ARRAY INDEX

Write Command: 85

Read Command: NA

Interpret: Acceptable values range from 0 to 7. This is the index number is used to set which PROGRAM STEP the INTEGRAL GAIN RAMP/SOAK ARRAY VALUE will be written. (Reference PROGRAM STEP number in TE Technology's LabVIEW-based GUI, Ramp Soak programming). The index number + 1 = PROGRAM STEP number.

72. INTEGRAL GAIN RAMP/SOAK ARRAY VALUE

Write Command: 86

Read Command: 87

Interpret: When writing, first use the INTEGRAL GAIN RAMP/SOAK ARRAY INDEX command to set the index value. Then use the write command to write the INTEGRAL GAIN RAMP/SOAK ARRAY VALUE.

When reading, just send the index value (0 to 7) with the Read Command to receive back the value at the indexed location.

73. DERIVATIVE RAMP/SOAK ARRAY INDEX

Write Command: 88

Read Command: NA

Interpret: Acceptable values 0 through 7. This is the index number is used to set which PROGRAM STEP the DERIVATIVE RAMP/SOAK ARRAY VALUE will be written. (Reference PROGRAM STEP number in TE Technology's LabVIEW-based GUI, Ramp Soak programming). The index number + 1 = PROGRAM STEP number.

74. DERIVATIVE RAMP/SOAK ARRAY VALUE

Write Command: 89 send with derivative value for the index setting in 73 above.

Read Command: 8a send index (0 to 7) with read command

Interpret: When writing, first use the DERIVATIVE RAMP/SOAK ARRAY INDEX command to set the index value. Then use the write command to write the DERIVATIVE RAMP/SOAK ARRAY VALUE.

When reading, just send the index value (0 to 7) with the Read Command to receive back the value at the indexed location.

75. READ PROPORTIONAL BANDWIDTH VALUE IN USE

Read Command: 99

76. READ INTEGRAL GAIN VALUE IN USE

Read Command: 9a

77. READ DERIVATIVE GAIN VALUE IN USE

Read Command: 9b

78. PCB Temperature

Read Command: 0c

79. INTERLOCK ENABLE

Write Command: 48

Read Command: 7d

Interpret:       0 == disabled  
                  1 == enabled no latching  
                  2 == enabled with latching

80. FACTORY DEFAULT RESTORE VALUE

Write Command: 10

Read Command: NA

Interpret: Send command with value 123<sub>10</sub> (which converts to 7b<sub>16</sub>) to restore settings to factory default condition.

## V. ASCII Reference Table

Dec	Oct	Hex	Binary	Description
000	000	00	00000000	^@ ^` NULL NUL null c-@ c-`
001	001	01	00000001	^A ^a SOH GTL c-A c-a start-of-heading
002	002	02	00000010	^B ^b STX c-B c-b start-of-text
003	003	03	00000011	^C ^c ETX c-C c-c end-of-text
004	004	04	00000100	^D ^d EOT SDC end-of-transmission c-D c-d ..._.
005	005	05	00000101	^E ^e ENQ PPC c-E c-e enquiry
006	006	06	00000110	^F ^f ACK c-F c-f acknowledge
007	007	07	00000111	^G ^g BELL BEL bell c-G c-g \a
008	010	08	00001000	^H ^h BS GET backspace c-H c-h \b
009	011	09	00001001	^I ^i TAB TCT HT tab c-I c-i \t
010	012	0A	00001010	^J ^j LF lf linefeed c-J c-j \n
011	013	0B	00001011	^K ^k VT vertical-tab c-K c-k \v
012	014	0C	00001100	^L ^l FF ff formfeed page \f c-L c-l
013	015	0D	00001101	^M ^m CR cr carriage-return c-M c-m \r
014	016	0E	00001110	^N ^n SO c-N c-n shift-out
015	017	0F	00001111	^O ^o SI c-O c-o shift-in
016	020	10	00010000	^P ^p DLE c-P c-p data-link-escape
017	021	11	00010001	^Q ^q DC1 LLO go XON xon c-Q c-Q
018	022	12	00010010	^R ^r DC2 c-R c-r
019	023	13	00010011	^S ^s DC3 stop XOFF xoff c-S c-s
020	024	14	00010100	^T ^t DC4 DCL c-T c-t
021	025	15	00010101	^U ^u NAK PPU negative-acknowledge c-U c-u
022	026	16	00010110	^V ^v SYN c-V c-v synchronous-idle
023	027	17	00010111	^W ^w ETB end-of-transmission-block c-W c-w
024	030	18	00011000	^X ^x CAN SPE c-X c-x cancel
025	031	19	00011001	^Y ^y EM SPD c-Y c-y end-of-medium
026	032	1A	00011010	^Z ^z SUB suspend c-Z c-z substitute
027	033	1B	00011011	^[ ^{ ESC escape c-[ c-{ m-
028	034	1C	00011100	^\\ ^  FS field-separator c-\ c-
029	035	1D	00011101	^] ^} GS group-separator
030	036	1E	00011110	^^ ^~ RS record-separator c-^ c-~
031	037	1F	00011111	^_ ^DEL unit-separator US c-_ c-DEL
032	040	20	00100000	SPC space spc
033	041	21	00100001	! exclamation-point
034	042	22	00100010	" straight-double-quotation-mark
035	043	23	00100011	# number-sign
036	044	24	00100100	\$ @@ dollar-sign
037	045	25	00100101	% percent-sign
038	046	26	00100110	& ampersand
039	047	27	00100111	' apostrophe
040	050	28	00101000	( left-parenthesis
041	051	29	00101001	) right-parenthesis
042	052	2A	00101010	* asterisk star
043	053	2B	00101011	+ addition-sign
044	054	2C	00101100	, comma
045	055	2D	00101101	- subtraction-sign minus hyphen negative dash
046	056	2E	00101110	. period dot decimal

```

047 057 2F 00101111 / right-slash
048 060 30 00110000 0
049 061 31 00110001 1
050 062 32 00110010 2
051 063 33 00110011 3
052 064 34 00110100 4
053 065 35 00110101 5
054 066 36 00110110 6
055 067 37 00110111 7
056 070 38 00111000 8
057 071 39 00111001 9
058 072 3A 00111010 : colon
059 073 3B 00111011 ; semicolon
060 074 3C 00111100 < less-than
061 075 3D 00111101 = equals
062 076 3E 00111110 > greater-than, right-chevron
063 077 3F 00111111 ? question-mark, query
064 100 40 01000000 @ at-symbol, at-sign
065 101 41 01000001 A
066 102 42 01000010 B
067 103 43 01000011 C
068 104 44 01000100 D
069 105 45 01000101 E
070 106 46 01000110 F
071 107 47 01000111 G
072 110 48 01001000 H
073 111 49 01001001 I
074 112 4A 01001010 J
075 113 4B 01001011 K
076 114 4C 01001100 L
077 115 4D 01001101 M
078 116 4E 01001110 N
079 117 4F 01001111 O

080 120 50 01010000 P
081 121 51 01010001 Q
082 122 52 01010010 R
083 123 53 01010011 S
084 124 54 01010100 T
085 125 55 01010101 U
086 126 56 01010110 V
087 127 57 01010111 W
088 130 58 01011000 X
089 131 59 01011001 Y
090 132 5A 01011010 Z
091 133 5B 01011011 [ left-bracket, open-square
092 134 5C 01011100 \ left-slash, backslash bash
093 135 5D 01011101 ] right-bracket, close-square
094 136 5E 01011110 ^ hat, circumflex, caret, up-arrow
095 137 5F 01011111 _ UNT, underscore, underbar

096 140 60 01100000 ` accent-grave, backprime, backquote
097 141 61 01100001 a

```



098	142	62	01100010	b
099	143	63	01100011	c
100	144	64	01100100	d
101	145	65	01100101	e
102	146	66	01100110	f
103	147	67	01100111	g
104	150	68	01101000	h
105	151	69	01101001	i
106	152	6A	01101010	j
107	153	6B	01101011	k
108	154	6C	01101100	l
109	155	6D	01101101	m
110	156	6E	01101110	n
111	157	6F	01101111	o
112	160	70	01110000	p
113	161	71	01110001	q
114	162	72	01110010	r
115	163	73	01110011	s
116	164	74	01110100	t
117	165	75	01110101	u
118	166	76	01110110	v
119	167	77	01110111	w
120	170	78	01111000	x
121	171	79	01111001	y
122	172	7A	01111010	z
123	173	7B	01111011	{ left-brace begin
124	174	7C	01111100	logical-or vertical-bar
125	175	7D	01111101	} right-brace end
126	176	7E	01111110	~ similar
127	177	7F	01111111	^? DEL rubout delete

## Appendix C – Programming Custom Sensor Curves

### Hardware operation:

First let's look at the controller's sensor circuitry. Sensors are connected to JP2 at terminals 1 and 2 (control sensor), and 3 and 4 (secondary sensor). Each sensor is in series with a 6650 ohm resistor that forms a voltage divider.

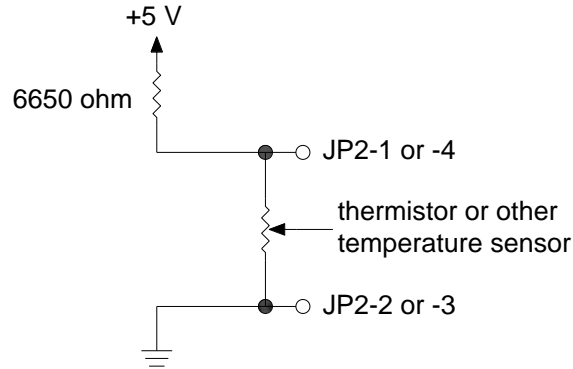

The voltage at JP2-1 and JP2-2 (or JP2-3 and JP2-4) can be calculated with the formula:

$$V_{SENSOR} = 5V \left( \frac{SENSOR\_ \Omega}{6650\Omega + SENSOR\_ \Omega} \right)$$

The controller then reads the voltage using a 16 bit digital-to-analog (D-A) converter for each sensor input. The temperature resolution that is measurable with the controller is dependent on the voltage change per °C from the sensor. The minimum voltage change the controller can measure is  $5V/2^{16} = 5V/65536 = 0.000763V$ . The maximum temperature resolution of the controller is 0.01 °C. If a temperature change of more than 0.01°C is required to achieve this minimum voltage change, the controller will not be able to fully resolve temperatures to a 0.01 °C resolution.

### Creating A User Defined Temperature Sensor Curve:

There are several basic steps we have followed for creating a user-defined sensor curve:

1. Create an index column in a spreadsheet program with the numbers 0 through 128
2. Assign a voltage value next to each to each index number, these should span from 0 to 5 V. This represents the range of sensor voltages as measured by the controller
3. Assign a corresponding temperature value next to each voltage
4. Make a .csv file containing the temperature data only, and upload it to the controller

The following example shows how to create a user defined thermistor curve. We will use the 15k thermistor as our example. It varies from 146,735 ohms to 1014 ohms over the temperature range of -20 °C to 100 °C. We can determine the extreme values for the sensor voltage. This is 4.78 V at 146,735 ohms, and 0.66 V at 1014 ohms.

There are 129 locations in the array corresponding to voltages ranging from 0 to 5 V. Consequently, the voltage for each index ( $5V/128 = 0.039V$  per increment) is shown in the VOLTAGE column in table below. The temperature corresponding to each voltage can then be entered at the corresponding index location. For index voltages above and below the sensor maximum and minimum voltages, the corresponding maximum and minimum temperatures are used. The table below shows the temperatures that correspond to each index location for our example 15k thermistor.

<u>INDEX</u>	<u>VOLTAGE</u>	<u>TEMP.</u>	<u>INDEX</u>	<u>VOLTAGE</u>	<u>TEMP.</u>	<u>INDEX</u>	<u>VOLTAGE</u>	<u>TEMP.</u>
0	0.00	100	43	1.68	62.8	86	3.36	27.2
1	0.04	100	44	1.72	61.8	87	3.40	26.4
2	0.08	100	45	1.76	60.8	88	3.44	25.5
3	0.12	100	46	1.80	59.9	89	3.48	24.7
4	0.16	100	47	1.84	58.9	90	3.52	23.8
5	0.20	100	48	1.88	58	91	3.55	23.1
6	0.23	100	49	1.91	57.3	92	3.59	22.3
7	0.27	100	50	1.95	56.3	93	3.63	21.4
8	0.31	100	51	1.99	55.4	94	3.67	20.5
9	0.35	100	52	2.03	54.5	95	3.71	19.6
10	0.39	100	53	2.07	53.6	96	3.75	18.6
11	0.43	100	54	2.11	52.8	97	3.79	17.7
12	0.47	100	55	2.15	51.9	98	3.83	16.7
13	0.51	100	56	2.19	51	99	3.87	15.8
14	0.55	100	57	2.23	50.2	100	3.91	14.8
15	0.59	100	58	2.27	49.3	101	3.95	13.8
16	0.63	100	59	2.30	48.7	102	3.98	13
17	0.66	100	60	2.34	47.9	103	4.02	11.9
18	0.70	98	61	2.38	47	104	4.06	10.8
19	0.74	95.6	62	2.42	46.2	105	4.10	9.7
20	0.78	93.5	63	2.46	45.4	106	4.14	8.6
21	0.82	91.6	64	2.50	44.6	107	4.18	7.4
22	0.86	89.7	65	2.54	43.8	108	4.22	6.2
23	0.90	87.9	66	2.58	43	109	4.26	5
24	0.94	86.2	67	2.62	42.1	110	4.30	3.7
25	0.98	84.6	68	2.66	41.3	111	4.34	2.3
26	1.02	83	69	2.70	40.5	112	4.38	0.89
27	1.05	81.9	70	2.73	39.9	113	4.41	-0.22
28	1.09	80.4	71	2.77	39.1	114	4.45	-1.76
29	1.13	79	72	2.81	38.3	115	4.49	-3.38
30	1.17	77.6	73	2.85	37.5	116	4.53	-5.1
31	1.21	76.2	74	2.89	36.7	117	4.57	-6.93
32	1.25	75	75	2.93	35.9	118	4.61	-8.91
33	1.29	73.7	76	2.97	35.1	119	4.65	-11
34	1.33	72.5	77	3.01	34.3	120	4.69	-13.4
35	1.37	71.3	78	3.05	33.5	121	4.73	-16
36	1.41	70	79	3.09	32.7	122	4.77	-18.9
37	1.45	69	80	3.13	31.9	123	4.80	-20
38	1.48	68.1	81	3.16	31.3	124	4.84	-20
39	1.52	67	82	3.20	30.5	125	4.88	-20
40	1.56	66	83	3.24	29.7	126	4.92	-20
41	1.60	64.9	84	3.28	28.9	127	4.96	-20
42	1.64	63.8	85	3.32	28	128	5.00	-20

You must now create a .csv file. This is most easily created using Excel by entering the temperatures in a single column. You could also use a text editor with each line containing only one temperature and a carriage return. The screen shot below of an Excel spreadsheet shows how this should look. (The screenshot only shows the first 34 rows though.)

	A	B	C	D	E	F	G	H	I	J	K	L	M	N
1	100													
2	100													
3	100													
4	100													
5	100													
6	100													
7	100													
8	100													
9	100													
10	100													
11	100													
12	100													
13	100													
14	100													
15	100													
16	100													
17	100													
18	100													
19	98													
20	95.6													
21	93.5													
22	91.6													
23	89.7													
24	87.9													
25	86.2													
26	84.6													
27	83													
28	81.9													
29	80.4													
30	79													
31	77.6													
32	76.2													
33	75													
34	73.7													
35	72.5													

Save the .csv file with a convenient file name. In our example, it is saved as 15kthermistor.csv. Open the Sensor menu, and click the “Configure Sensor” button. The screen shown below then pops up; click the “Load User Defined Sensor Table” button, and then select the .csv file. The resulting graph plots the data and can provide a visual confirmation of whether there are any data entry errors associated with discontinuities. Then click exit.

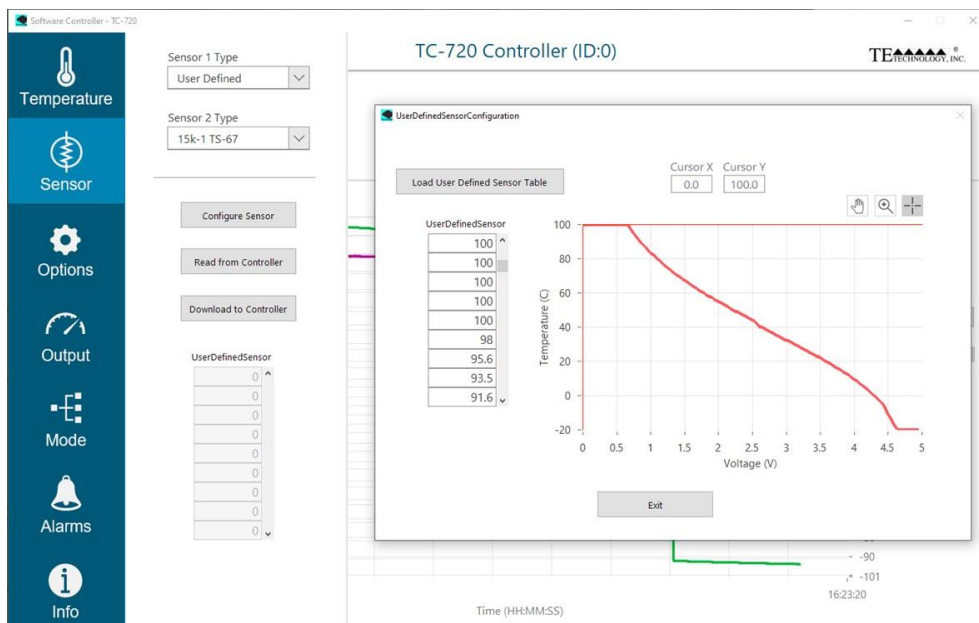

Then click the “Download to Controller” button. Finally, select “User Defined” for the sensor type, and the controller will begin using the new sensor.

You can also click the “Read from Controller” button. This will show the data in the “UserDefinedSensor” table so you can verify that the controller does in fact have the correct user-defined sensor curve programmed. The table will not show the full resolution of the data you entered though; it is just a quick check to verify the sensor is programmed into the controller.

The controller is not limited to using thermistors. It can also use such devices as the LM335 where its voltage varies linearly with temperature. The following example shows how to set up the controller to use an LM335.

The LM335 provides a linear output voltage directly proportional to temperature at 10 mV/K. It provides a range from -40 °C to 100 °C. The LM335 has an output of 2.98 V at 25 °C (298 K): at -40 °C, the output is 2.33 V, and at 100 °C, it is 3.73 V. Recall from the previous example that we have 129 index locations spanning over a 0 V to 5 V range. The volts per location equal  $5V/128 = 39.06 \text{ mV/location}$ . This leaves 60 ( $2.33 \text{ V}/0.03906 \text{ V} = 59.65$ ) locations at the low end of the table that would be filled with the low temperature value of -40 °C. The upper end of the table is filled with the upper limit of 100 °C in 33 locations [ $(5 \text{ V} - 3.73 \text{ V})/0.03906 \text{ V} = 32.6$ ]. The remaining 36 locations ( $129 - 60 - 33 = 36$ ), are used to map the temperature range of the LM335.

Below is a table showing the temperature values corresponding to their respective index locations. The index locations are shown for reference only. As in the previous example above, you would only enter the temperatures in a single column to create the .csv file.

1	-40	27	-40	53	-40	79	31.54	105	100
2	-40	28	-40	54	-40	80	35.44	106	100
3	-40	29	-40	55	-40	81	39.35	107	100
4	-40	30	-40	56	-40	82	43.26	108	100
5	-40	31	-40	57	-40	83	47.16	109	100
6	-40	32	-40	58	-40	84	51.07	110	100
7	-40	33	-40	59	-40	85	54.98	111	100
8	-40	34	-40	60	-40	86	58.88	112	100
9	-40	35	-40	61	-38.78	87	62.79	113	100
10	-40	36	-40	62	-34.87	88	66.69	114	100
11	-40	37	-40	63	-30.96	89	70.6	115	100
12	-40	38	-40	64	-27.06	90	74.51	116	100
13	-40	39	-40	65	-23.15	91	78.41	117	100
14	-40	40	-40	66	-19.24	92	82.32	118	100
15	-40	41	-40	67	-15.34	93	86.23	119	100
16	-40	42	-40	68	-11.43	94	90.13	120	100
17	-40	43	-40	69	-7.52	95	94.04	121	100
18	-40	44	-40	70	-3.62	96	97.94	122	100
19	-40	45	-40	71	0.29	97	100	123	100
20	-40	46	-40	72	4.19	98	100	124	100
21	-40	47	-40	73	8.1	99	100	125	100
22	-40	48	-40	74	12.01	100	100	126	100
23	-40	49	-40	75	15.91	101	100	127	100
24	-40	50	-40	76	19.82	102	100	128	100
25	-40	51	-40	77	23.73	103	100	129	100
26	-40	52	-40	78	27.63	104	100		

### Appendix D – Programming Ramp/Soak Routines

Ramp/Soak routines can be created to run long repeated processes or simple routines. In the example shown below, the controller will begin applying power to the TE device in the heating or cooling mode as required in order to reach 25 °C in 100 seconds (assuming the TE device is capable of providing this ramp rate). The controller then will hold this temperature for the next 100 seconds using the proportional bandwidth (P), integral gain (I), and derivative gain (D) settings. The controller will then proceed to step 2, taking 100 seconds to reach 30 °C, and then maintaining 30 °C for the next 100 seconds. The controller will then proceed to step 3 and so on. After the controller finishes step 8, the program will automatically end, and the controller will set the main output% to 0%.

**Ramp Soak Configuration** ✕

Program Step	Set Temp (°C)	Ramp Time (seconds)	Soak Time (seconds)	P	I	D	Go To Step	Repeats
1	25	100	100	5	1	0	0	0
2	30	100	100	5	1	0	0	0
3	35	100	100	5	1	0	0	0
4	40	100	100	5	1	0	0	0
5	45	100	100	5	1	0	0	0
6	50	100	100	5	1	0	0	0
7	55	100	100	5	1	0	0	0
8	60	100	100	5	1	0	0	0

Timer Mode

Set Temperature       Sensor Temperature

Max Temp Delta From Timer

Here's another example showing the program GO TO STEP operation:

**Ramp Soak Configuration** ✕

Program Step	Set Temp (°C)	Ramp Time (seconds)	Soak Time (seconds)	P	I	D	Go To Step	Repeats
1	15	0	60	2	1	0	0	1
2	20	60	60	1	0	0	0	1
3	15	60	0	1	0	0	1	12
4	10	60	60	2	1	0	0	1
5	5	60	60	2	1	0	0	1
6	0	60	60	2	1	0	0	12
7	25	60	60	2	1	0	1	3600
8	0	0	0	0	0	0	0	0

Timer Mode

Set Temperature

Sensor Temperature

Max Temp Delta From Timer

Exit

- a. The controller will execute steps 1, 2, and 3 twelve times
- b. The controller will execute steps 4, 5, and 6 twelve times.
- c. The controller will execute step 7
- d. The controller will repeat the sequences in a, b, and then c 3600 times.
- e. The program stops in step 8 because it contains all zeros. If GO TO STEP in program step 7 was a zero the routine would go to step 8 and end.

## Appendix E – Additional Notes on Fan Control

### Fan Speed Control, 2-Wire Fans

It is possible, though expressly NOT recommended, to pulse-width modulate (PWM) standard two-wire fans by connecting the ground wire to the Alarm 1 JP2-8 terminal and selecting “FAN CONTROL+ ”. However, this can be dangerous. The fan may appear to work for a while, and the fan speed may vary based on the control, but there can be long term problems. First the control may not be uniform. The speed response of the fan may not be uniform with the speed control output%. The speed response can also vary depending on the frequency of the control.

Second, and most important, the PWM input can cause physical damage to the fan motor. Since the fan is not rated for PWM speed control there is no specific PWM frequency that will be recommended. Higher frequencies may cause the internal commutation circuitry to malfunction. The motor will almost always run hotter. This degrades the spindle bearings more quickly, and it can overheat the electrolytic capacitors within the fan. During PWM control, the voltage applied to the fan is either its rated voltage or zero volts. However, because the fan is spinning at something less than its rated speed, its back EMF is reduced. This causes higher-than-nominal current flow through the windings during the on period of the PWM cycle. The motor windings can overheat, causing the winding insulation to break down. These negative effects may be minimized by using a low PWM frequency, but they will never be eliminated. The end result is that the fan can fail, and the user will not know when or how the fan will fail. Thus, the recommendation is do not PWM speed control a two-wire fan unless you know it is designed for PWM speed control.

However, some two-wire fans are designed for PWM control. They often incorporate an input filter to change the pulsed DC into a steady DC voltage. These fans are designed for a specific PWM frequency range.

### Fan Speed Control, 3-Wire Fans

Typically, the fan’s power leads are connected to the power source and the control is connected to the fan speed control terminal. The most common control will be “FAN CONTROL - ” mode. Refer to the fan manufacturer’s data for proper operation.

Issues to be mindful of are:

- Be sure that the speed control can be accomplished through a PWM input, and not an analog input.
- Many of these fans have a specific PWM frequency that is recommended, use the proper frequency.
- Sometimes 0 % duty cycle on the fan will cause the fan to operate at a minimum speed, other times it will stop the fan blades from rotating. Be sure to know how the fan you are using will respond.
- Some fans have an internal pull-up resistor on the input terminal, other times you may need to add this pull –up resistor externally.

### Fan Speed Control, 4 Wire Fans

These are similar to three wire speed controllable fans, so refer to the notes regarding 3-wire fans. 4-wire fans often have an additional output wire used as a speed monitor or an output alarm. The TC-720 cannot monitor these inputs. Be sure not to connect the speed monitor or an output alarm wires to the PWM control terminal on the TC-720.



## Fan Control Examples

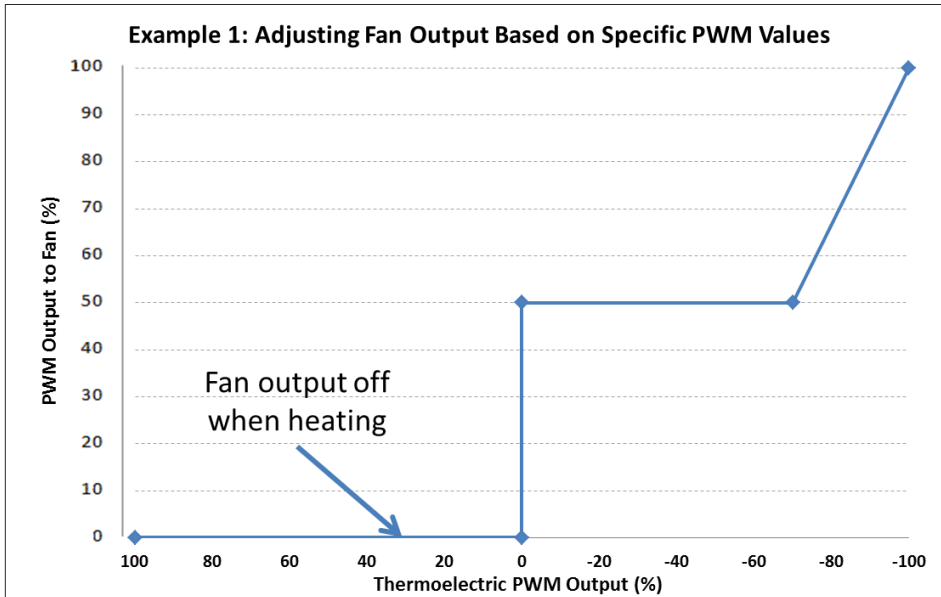

**Example 1:** Adjusting fan output based on TE PWM output value.

Example 1 Parameter	Setting
FAN OPERATION, HEAT MODE	FAN OFF
FAN PWM % MAXIMUM OUTPUT	100 %
FAN PWM % MINIMUM OUTPUT	50 %
INCREASE FAN SPEED STARTING AT	70 %

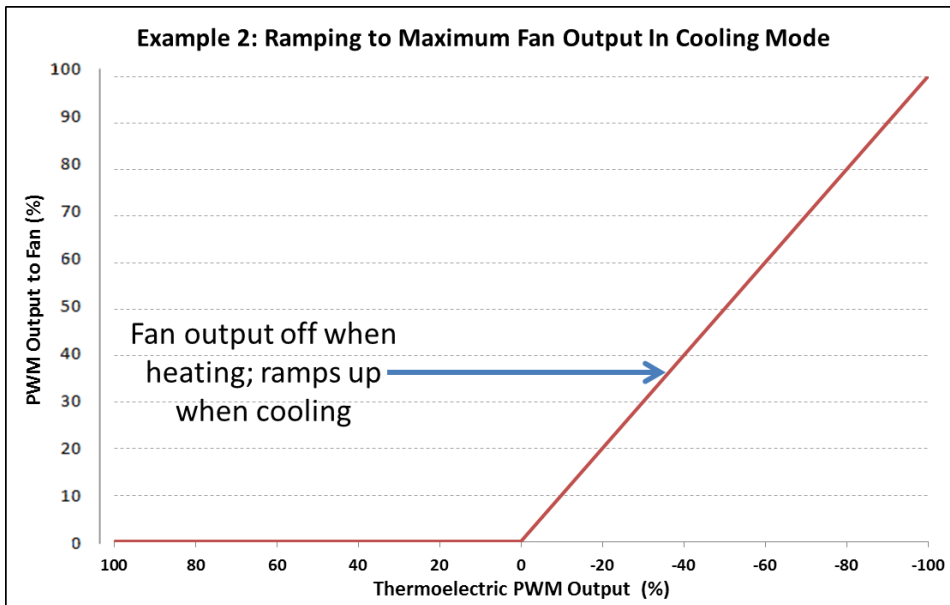

**Example 2:** A linear ramp in fan PWM output% as a function of TE PWM output %.

Example 2 Parameter	Setting
FAN OPERATION, HEAT MODE	FAN OFF
FAN PWM % MAXIMUM OUTPUT	100 %
FAN PWM % MINIMUM OUTPUT	0 %
INCREASE FAN SPEED STARTING AT	0 %

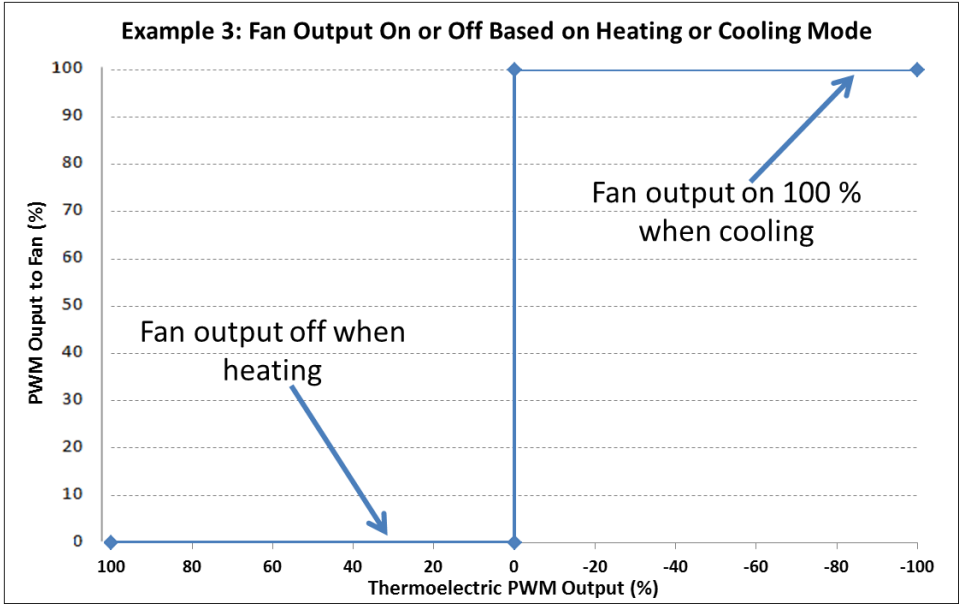

**Example 3:** This is the only fan control configuration acceptable for use with a 2 wire, non-speed controllable fan; the fan is either completely on or completely off.

Example 3 Parameter	Setting
FAN OPERATION, HEAT MODE	FAN OFF
FAN PWM % MAXIMUM OUTPUT	100 %
FAN PWM % MINIMUM OUTPUT	100 %
INCREASE FAN SPEED STARTING AT	0 %

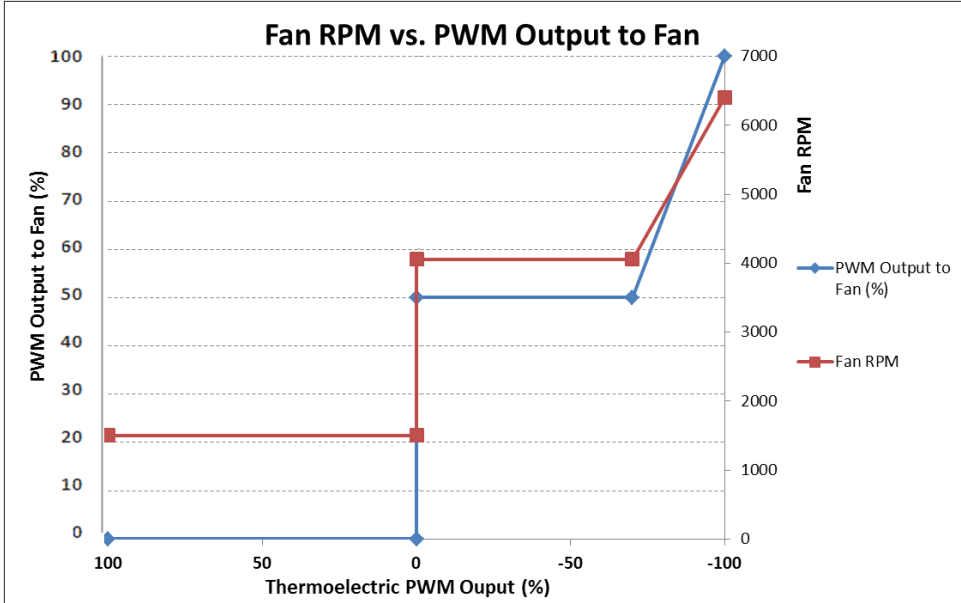

**Example 4:** Fan speed (RPM) changes will vary depending on fan model. This fan, as with many other fans, will still run at a minimum RPM above zero even when the fan output is off.

Parameter	Setting
FAN OPERATION, HEAT MODE	FAN OFF
FAN PWM % MAXIMUM OUTPUT	100 %
FAN PWM % MINIMUM OUTPUT	50 %
INCREASE FAN SPEED STARTING AT	70 %

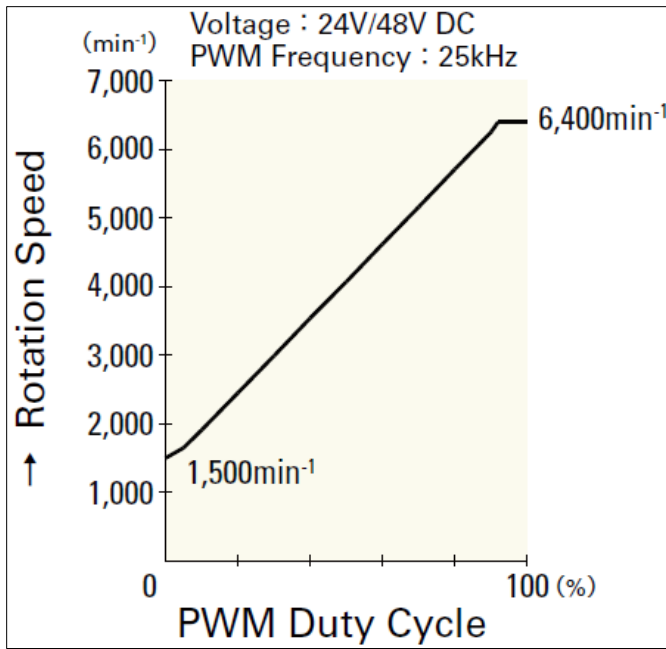

The graph above in this example is based on the fan Manufacturer's published relationship between fan PWM Duty Cycle and rotational speed.