

**Instruction Manual
For
Model TC-36-25 RS485
Thermoelectric Cooler
Temperature Controller**

**17-OCT-2023
Drawing #5106 Rev. E**



**1590 Keane Drive
Traverse City, MI 49696-8257
<http://www.tetech.com>**

**Phone: (231) 929-3966
Fax: (231) 929-4163
e-mail: cool@tetech.com**

All Materials Copyright © 2023, TE Technology, Inc.

General Safety Warnings



This manual is available in English only. It must be read and followed carefully before installation and operation.



THE LATEST REVISION OF THIS MANUAL IS AVAILABLE AT www.tetech.com. Verify that you are using the latest revision available.



The TC-36-25 RS485 should not be used as a toy, or serious injury could result. The TC-36-25 RS485 should only be used for its intended purpose of providing temperature control of TE Technology's thermoelectric devices only. The controller is intended for light industrial, laboratory, or similar use. It is not intended for household use or medical use.



Do not use in an explosive or potentially explosive environment.



Do not use the TC-36-25 RS485 to control capacitive or inductive loads or the controller could be damaged and/or overheat. Examples of capacitive or inductive loads include but are not limited to motors, fans, filters, and solenoids.



Do not allow the electrical connections on the printed circuit board to touch any electrically conductive surfaces.



Do not operate in an environment where the controller could come in contact with condensation, water, metal shavings, dirt or other contaminants, or electrically conductive materials.



Use ESD (Electro Static Discharge) protection when installing the controller or coming in contact with electrical connections or components on the controller.



Do not touch any of the electrical connections or components of the TC-36-25 RS485 while the controller is energized. Doing so can disrupt the function of the controller.



Do not use if the controller has been damaged in any way.



Only qualified technicians should install and operate this controller with the appropriate personal protective equipment.



Improper tuning of this temperature controller can lead to excessive thermal cycling and/or overheating of the thermoelectric device, either of which are known to reduce the lifetime of any thermoelectric device. Care should be taken to prevent the temperature of the thermoelectric device from going beyond the range specified by the device manufacturer. Care should also be taken so that any thermal cycling of the thermoelectric device is a result of changes in the controller's set-point temperature and not instability at a given set point due to improper selection of the tuning variables.



The temperature controller base underneath the transistor-mounting area could exceed 60 °C under normal operation. Use caution! Protect against accidental contact with hot surfaces.



Use protection devices to prevent hazardous conditions and/or damage to equipment.



Each power input that is used with the controller must be fused separately. Alternatively, a power supply with integral over-current protection may be used if it is appropriately sized for protecting the controller/TE device.



The temperature controller is intended to be used with, or incorporated into, other machinery made by TE Technology, Inc. and must not be put into service until the relevant machinery into which it is to be incorporated into has been declared in conformity with the essential requirements of the Machinery Directive 2006/42/EC.

For more information regarding protection devices read, TE Technology's Thermoelectric Cooling Assembly (TCA) Instruction manual which is available for download from TE Technology's website at www.tetech.com. The terms and provisions relating to protection devices as provided in the TCA Instruction manual are hereby incorporated by reference. A copy of the TCA Instruction manual can also be sent via regular mail upon request.

TE Technology, Inc. does not make any warranty, expressed or implied, that the use or operation of the equipment will be functional or effective if the equipment is not installed and used in accordance with this manual.

TE Technology, Inc. shall not be liable, and Purchaser shall defend, hold harmless, and indemnify TE Technology, Inc. from and against, any losses, costs, expenses (including reasonable attorneys' fees), injuries, liabilities or damages of any kind or nature whatsoever, arising out of the use or inability to use this TE Technology, Inc. product, from the omission or failure to use protection devices, or from failure to comply with this manual. This provision is in addition to any other indemnification provisions which are a part of the Purchase Order or contract with Purchaser.

Table of Contents

License Agreement	5
Features	8
Setup Instructions.....	14
1.0 Initial Setup	14
2.0 Controller Setup	20
3.0 FINAL SETUP—CONTROLLER TUNING.....	31
Controller Wiring Diagram: TC-36-25 RS485 with One Power Supply Setup	34
Controller Wiring Diagram: TC-36-25 RS485 with Two Power Supplies Setup.....	35
Expansion Connector Wiring Diagram.....	36
Mechanical Package Drawing.....	37
Block Diagram.....	37
RS485 Communications Connections.....	39
Appendix A Troubleshooting Controller	40
APPENDIX B: Troubleshooting Communications	42
APPENDIX C: Serial Communications.....	43
APPENDIX D: Thermistors for TC-36-25 RS485.....	56
APPENDIX E: Multiple Controller (RS-485) Wiring Diagram	61

TE TECHNOLOGY, INC. (TE TECH)

License Agreement

CAREFULLY READ THE FOLLOWING TERMS AND CONDITIONS BEFORE OPENING THIS PACKAGE OR SIGNIFYING YOUR ACCEPTANCE BY CLICKING THE APPROPRIATE DIALOG BOX. OPENING THIS PACKAGE, CLICKING THE APPROPRIATE DIALOG BOX OR USING ANY PART OF THE SOFTWARE SIGNIFIES YOUR ACCEPTANCE OF (1) THESE TERMS AND CONDITIONS FOR THE LICENSED SOFTWARE, AND (2) THE TERMS OF ACCEPTANCE OF TE TECH FOR ANY PRODUCTS PURCHASED FROM TE TECH. IF YOU DO NOT AGREE WITH THEM, PROMPTLY RETURN THE PACKAGE UNOPENED AND UNUSED ALONG WITH ANY OTHER ITEM THAT WAS INCLUDED IN THE SAME PRODUCT NUMBER FOR FULL CREDIT.

You, as the Customer, agree as follows:

1. DEFINITIONS

“Application Software” shall mean those portions of the Licensed Software created by TE TECH.

“Designated Hardware” shall mean the one (1) hardware device, purchased from TE TECH, upon which Customer shall run the Licensed Software.

“Licensed Software” shall mean the Application Software plus any other software supplied by TE TECH pursuant to this Agreement.

“Third Party Software” shall mean software owned or licensed by a third party, including but not limited to operating systems, that is embedded within the Licensed Software or otherwise included with any product provided to Customer from TE TECH.

2. LICENSE

2.1 Except as provided in section 2.2 below, you are granted only a personal, non-transferable, nonexclusive license to use the Licensed Software only on the Designated Hardware. You may copy the Licensed Software into machine readable form for backup purposes or to support your use of the Licensed Software on the Designated Hardware. No other copies shall be made unless authorized in writing by TE TECH. You may not (i) reverse engineer, decompile, or disassemble the Licensed Software (except to the extent such foregoing restriction is expressly prohibited by applicable law); (ii) sub-license, lease, or rent the Licensed Software; (iii) distribute in part, modify, or create derivatives of the Licensed Software; (iv) amend, modify, or supplement Licensed Software with any additional code except for the purpose of further configuring the Licensed Software for use with Designated Hardware; or (v) directly or indirectly, export, re-export, download, or ship the Licensed Software in violation of the laws and regulations of the U.S. The Licensed Software, comprising proprietary trade secret information of TE TECH and/or its Licensor’s, shall be held in confidence by Customer and protected from disclosure to third parties. No title to the intellectual property is transferred, You must reproduce and include all applicable copyright notices on any copy. Licensed Software shall not be copied, reproduced, or used for any other purpose outside of operation of the TE TECH hardware, and shall not be used on any other piece of hardware other than the TE TECH hardware with, or for, which it was provided. Notwithstanding the foregoing, in the event that you download the Licensed Software from the internet without purchasing Designated Hardware, the Licensed Software may only be used for evaluation purposes and must be deleted (including all copies) within fifteen (15) days of downloading. You may not use the Licensed Software with any other equipment other than the Designated Hardware without prior written approval from TE TECH. If no operating system software is included in the software provided under this Agreement, you must make provision for any required operating system software licenses. At its option, TE TECH may, upon request, provide the source code for the Licensed Software. The limited warranty provided in section 3 below shall be null and void immediately upon TE TECH providing the source code, or any portion thereof, to you.

2.2 If you are an authorized TE TECH distributor or an Original Equipment Manufacturer who incorporates the Licensed Software into your equipment for sale to an end user, or you use the Licensed Software to create redistributables, you may transfer the Licensed Software to an end user provided that the end user agrees to be bound by the provisions of this Agreement. You shall use your best efforts to enforce your agreement with customers made in accordance with this Section 2.2 and shall promptly report any violation or suspected violation to TE TECH. In the event that your customer violates any portion of this agreement, you agree to defend, hold harmless and indemnify TE TECH from any and all such claims. TE TECH may, at its option, bring suit against your customer to enforce the terms of this agreement, TE TECH’s costs and expenses incurred as a result of such action (including reasonable attorneys’ fees) shall be your responsibility.

2.3 The Licensed Software may include Third Party Software licensed to TE TECH. Customer hereby acknowledges and agrees that any Third Party Software provided by TE TECH to Customer hereunder (a) shall not be modified and shall be used and/or used and redistributed or resold (to the extent permitted under Section 2.2) only embedded within the TE TECH hardware product as provided by TE TECH, (b) shall always contain and only be redistributed (to the extent permitted under Section 2.2) with all proprietary markings present as provided to Customer hereunder and under the same terms and conditions as set forth in this Agreement. All rights and benefits afforded to TE TECH under this Agreement shall apply equally to the owner of the Third Party Software (the “Third Party”) and its licensors with respect to the Third Party Software. The Third Party and its licensors are intended third party beneficiaries of this Agreement, and the provisions of this Agreement relating to the Licensed Software, as the same incorporate the Third Party Software, are made expressly for the benefit of, and are enforceable by, the Third Party and its licensors. The Third Party and its licensors retain ownership of all copies of the Third Party Software. **Unless a pass-through warranty covering the Third Party Software is extended directly to you by the Third Party, all Third Party Software is provided “AS IS” without warranty of any kind, and each Third Party and its licensors disclaim all warranties, either express or implied, including but not limited to the implied warranties of merchantability, title, non-infringement or fitness for a particular purpose with regard to the Third Party Software. The Third Party shall not have any liability for special, indirect, punitive, incidental or consequential damages.**

2.4 EXCEPT AS PROVIDED IN SECTION 2.2 ABOVE, IF YOU TRANSFER POSSESSION OF ANY COPY OF THE LICENSED SOFTWARE TO ANOTHER PARTY WITHOUT WRITTEN CONSENT OF TE TECH, YOUR LICENSE IS AUTOMATICALLY TERMINATED. Any attempt otherwise to sublicense, assign or transfer any of the right, duties or obligations hereunder is void.

2.5 If the Licensed Software or associated documentation is provided to any U.S. Government entity, unit, or agency, the restrictions set forth at section 52.227-19(c) (“Commercial computer software - restricted rights”) of the Federal Acquisition Regulations (FARs) shall apply. If the Licensed Software or associated documentation is provided to the U.S. Government, Department of Defense (DOD), or any entity, unit, or agency thereof, the restrictions set forth at section 252.227-7015 (“Technical Data - Commercial Items”) of the DOD FAR Supplement (DFARS) shall also apply.

2.6 For rights granted in this Agreement, Customer shall pay to TE TECH the then-current product price (license fee) for each copy of the Licensed Software provided by TE TECH to Customer.

2.7 Customer shall pay all import duties and registration fees and all sales, use and excise taxes (and any other assessments in the nature of taxes however designated) on the Licensed Software or its license to use the Licensed Software, or resulting from this Agreement, exclusive of taxes based on TE TECH’s net income.

2.8 Customer acknowledges that the Licensed Software, including, without limitation, TE TECH logos, trademarks and all information contained therein, is proprietary to TE TECH, is valuable, gives a competitive advantage to TE TECH, and could not, without significant expense and difficulty, be obtained or duplicated by others who have not been able to acquire the same through means expressly authorized in this agreement. You agree that, unless you first obtain the prior written consent of TE TECH, or unless

required by law, you shall not communicate or disclose, directly or indirectly, to any person or firm, or use at any time, any of the TE TECH's proprietary information, except as provided in this Agreement. The provisions of the section, among certain others, shall survive the termination of this Agreement for whatever reason. The Licensed Software shall be and remain the exclusive property of TE TECH.

3. WARRANTY

3.1 Only if Customer has purchased Designated Hardware (the purchase price of which automatically includes the license fee), TE TECH warrants that the Application Software will be in substantial conformance with the specifications in the manual pertaining thereto as of the date of shipment by TE TECH. If, within ninety (90) days of date of shipment, it is shown that the Application Software does not meet this warranty, TE TECH will, at its option, either correct the defect or error in the Application Software, free of charge, or make available to Customer satisfactory substitute software, or, as a last resort, return to Customer all payments made as license fees and terminate the license with respect to the Application Software affected. TE TECH does not warrant that operation of the Application Software will be uninterrupted or error free or that it will meet Customer's needs. All other portions of the Licensed Software are provided "as is" without warranty of any kind.

3.2 TE TECH warrants that the media on which the Application Software is delivered will be free from defects in material or workmanship under normal use and service for a period of ninety (90) days from the date of delivery. If any defects are discovered in the media is discovered and reported by Customer within ninety (90) days after delivery TE TECH shall, at no cost to Customer, upon return of same to TE TECH, replace the media and deliver (electronically) to Customer a new and complete copy of the Licensed Software.

3.3 Any modification to the Licensed Software by the Customer without the express written consent of TE TECH shall void the warranty.

3.4 THE FOREGOING WARRANTIES ARE EXCLUSIVE AND ARE IN LIEU OF ALL OTHER WARRANTIES WITH RESPECT TO THE LICENSED SOFTWARE WHETHER WRITTEN, ORAL, IMPLIED OR STATUTORY. **NO IMPLIED OR STATUTORY WARRANTY OF MERCHANTABILITY OR FITNESS FOR A PARTICULAR PURPOSE SHALL APPLY. NO WARRANTY ARISING FROM COURSE OF PERFORMANCE, COURSE OF DEALING, OR USAGE OF TRADE SHALL APPLY. NOTWITHSTANDING ANYTHING TO THE CONTRARY HEREIN, UNLESS CUSTOMER HAS PAID TE TECH A SEPARATE LICENSE FEE THEREFOR, TE TECH MAKES NO WARRANTIES AS TO THE LICENSED SOFTWARE, WHICH IS PROVIDED "AS IS" WITHOUT WARRANTY OF ANY KIND, WHETHER EXPRESS OR IMPLIED.**

4. LIMITATION OF LIABILITY

4.1 IN NO EVENT, WHETHER AS A RESULT OF BREACH OF CONTRACT, BREACH OF WARRANTY, TORT (INCLUDING NEGLIGENCE) OR OTHERWISE, SHALL TE TECH OR ITS SUPPLIERS BE LIABLE FOR ANY SPECIAL, CONSEQUENTIAL, INCIDENTAL OR PENAL DAMAGES INCLUDING, BUT NOT LIMITED TO, LOSS OF PROFIT OR REVENUES, LOSS OF USE OF THE LICENSED SOFTWARE OR ANY PART THEREOF, OR ANY ASSOCIATED EQUIPMENT, DAMAGE TO ASSOCIATED EQUIPMENT, COST OF CAPITAL, COST OF SUBSTITUTE PRODUCTS, FACILITIES, SERVICES OR REPLACEMENT POWER, DOWN TIME COSTS, OR CLAIMS OF CUSTOMER'S CUSTOMERS AND TRANSFEREES FOR SUCH DAMAGES EVEN IF TE TECH HAS BEEN ADVISED OF THE POSSIBILITY OF SUCH DAMAGES.

4.2 EXCEPT AS PROVIDED IN SECTION 5, INDEMNITY, IN NO EVENT, WHETHER AS A RESULT OF BREACH OF CONTRACT OR WARRANTY, TORT (INCLUDING NEGLIGENCE) OR OTHERWISE, SHALL TE TECH'S LIABILITY TO CUSTOMER FOR ANY LOSS OR DAMAGE ARISING OUT OF, OR RESULTING FROM THIS AGREEMENT, OR FROM ITS PERFORMANCE OR BREACH, OR FROM THE LICENSED SOFTWARE OR ANY PART THEREOF, OR FROM ANY SERVICE FURNISHED HEREUNDER, EXCEED THE QUOTED CHARGES FOR THE LICENSED SOFTWARE. ANY SUCH LIABILITY SHALL TERMINATE UPON THE TERMINATION OF THE WARRANTY PERIOD AS SET FORTH IN SECTION 3.

4.3 If TE TECH furnishes Customer with advice or other assistance which concerns Licensed Software or any portion thereof supplied hereunder or any system or equipment on which any such software may be installed and which is not required pursuant to this Agreement the furnishing of such advice or assistance will not subject TE TECH to any liability, whether in contract, warranty, tort (including negligence) or otherwise.

4.4 The products (hardware and software) to be licensed or sold hereunder are not intended for use in any application specifically prohibited in writing by TE TECH, including, without limitation, in any nuclear, chemical or weapons production facility or activity, or other activity where failure of the products could lead directly to death, personal injury or severe physical or environmental damage. If so used, TE TECH disclaims all liability for any damages arising as a result of the hazardous nature of the business in question, including but not limited to nuclear, chemical or environmental damage, injury or contamination, and Customer shall indemnify, hold harmless and defend TE TECH, its officers, directors, employees and agents against all such liability, whether based on contract, warranty, tort (including negligence), or any other legal theory, regardless of whether TE TECH had knowledge of the possibility of such damages.

5. INDEMNITY

5.1 Should the Application Software be held by a court to constitute patent or copyright infringement and its use is enjoined, TE TECH shall, at its expense and option, either procure for Customer the right to continued use, or replace same with a non-infringing product or part, or modify the Application Software so that it becomes non-infringing, or remove the software and refund the license charge pertaining thereto (less reasonable depreciation for any period of use) and any transportation costs separately paid by Customer. The foregoing states the entire liability of TE TECH for patent and copyright infringement by the Licensed Software or any part thereof.

5.2 The indemnity under the preceding paragraph shall not apply to any use of Application Software in conjunction with any other product in a combination not furnished by TE TECH as a part of this transaction. As to any such use in such combination, or any improper or unauthorized use, installation, or operation of the Application Software, TE TECH assumes no liability whatsoever for patent and copyright infringement and Customer will hold TE TECH harmless against any infringement claims arising there from (including, but not limited to, reasonable attorney's fees).

6. TERM AND TERMINATION

6.1 You may terminate the license granted hereunder at any time by destroying the Licensed Software together with all copies thereof and notifying TE TECH in writing that all use of the Licensed Software has ceased and that same has been destroyed.

6.2 TE TECH, upon thirty (30) days' notice, may terminate this Agreement or any license hereunder if Customer fails to perform any obligation or undertaking to be performed by it under this Agreement or if Customer attempts to assign this Agreement without the prior written consent of TE TECH. Within twenty (20) days after any such termination of this Agreement, Customer shall certify in writing to TE TECH that all use of the Licensed Software has ceased, and that same has been returned or destroyed, in accordance with TE TECH's instructions.

6.3 Sections 4, 6 and 7 of this Agreement shall survive any expiration or termination and remain in effect. Termination of this Agreement or any license hereunder shall not relieve Customer of its obligation to pay any and all outstanding charges hereunder nor entitle Customer to any refund of such charges previously paid.

7. IMPORT/EXPORT

7.1 If you intend to import or export (or re-export), directly or indirectly, whether electronically or otherwise, the software products or technical data relating thereto supplied hereunder or any portion thereof, it is your responsibility to assure compliance with U.S. and other applicable governmental import and/or export control laws and, if appropriate, to secure any required licenses or approvals in your own name. You are also responsible for the accuracy and completeness of any information or certification you provide for purposes of import or export control compliance.

8. GENERAL

8.1 This Agreement shall be governed by the laws of the State of Michigan, without regard to its conflict of law provisions. You agree that any civil action or claims which relate to this Agreement or the Licensed Software must be brought and maintained in a court of competent jurisdiction located in Grand Traverse County, Michigan, or, alternatively, the U.S. District court for the Western District of Michigan. You hereby waive venue in any other forum. The provisions of the United Nations Convention on the International Sale of Goods shall not apply to this Agreement

8.2 Should you have any questions concerning this Agreement, contact TE TECH by writing to: TE TECHNOLOGY, INC., 1590 KEANE DRIVE, TRAVERSE CITY, MI 49686.

8.3 YOU ACKNOWLEDGE THAT YOU HAVE READ THIS AGREEMENT, UNDERSTAND IT AND AGREE TO BE BOUND BY ITS TERMS AND CONDITIONS. YOU FURTHER AGREE THAT IT IS THE COMPLETE AND EXCLUSIVE STATEMENT OF THE AGREEMENT BETWEEN US AND SUPERSEDES ANY PROPOSAL OR PRIOR AGREEMENT, ORAL OR WRITTEN, AND ANY OTHER COMMUNICATIONS BETWEEN US RELATING TO THE SUBJECT MATTER OF THIS AGREEMENT. FURTHER, NO CHANGE OR AMENDMENT TO THIS AGREEMENT SHALL BE EFFECTIVE UNLESS AGREED TO BY WRITTEN INSTRUMENT SIGNED BY A DULY AUTHORIZED REPRESENTATIVE OF TE TECH.

Features

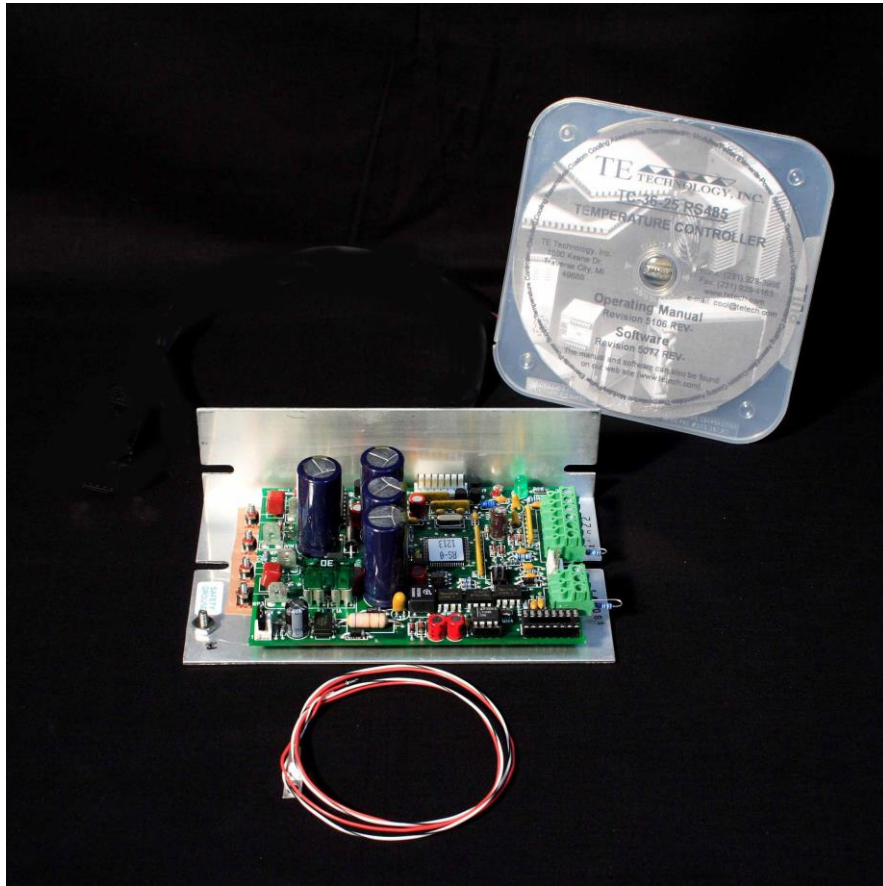

TC-36-25 RS485, Thermistor, I/O Cable, and Software

The TC-36-25 RS485 provides bi-directional (heating and cooling) temperature control for thermoelectric devices. Resistive heaters can also be controlled. An H-bridge configuration is used for the power output stage. The output stage is made from solid-state N-channel MOSFETs (no relays or mechanical components are used). These transistors are highly efficient and allow for the bi-directional flow of current through the thermoelectric coolers. Their high efficiency reduces the waste heat generated by the controller and allows for a compact design.

The TC-36-25 RS485 controller is programmable via a RS-485 port or RS-485 port adapter. The TC-36-25 RS485 can be networked with up to 254 controllers on one RS485 communications port. Field selectable parameters or data acquisition in a half duplex mode can be performed. The supplied software is compatible with Windows 10/8/7. The software provides a graphical user interface for setting control parameters and receiving feedback from the temperature sensor(s). However, the command set is also provided so that qualified personnel can use the controller as an embedded control, or they can create a custom program interface. The software can also be used to instruct the TC-36-25 RS485 to save the desired control parameters to the controller's non-volatile memory. This allows the controller to be disconnected from the computer and operated as a stand-alone controller. When operating as a stand-alone controller, the controller can be set to always control to the stored set point or it can be set up to accept a proportional signal to vary the set point as required.

Mechanically, the controller's printed circuit board is mounted to a metal bracket that is suitable for either horizontal or vertical orientation. The controller can operate in ambient temperatures from 0 °C to 60 °C without generally requiring additional heat sinking. The controller is intended to be used in locations where the controller can be protected by a secondary enclosure or other means of protection.

The MP-2986 Display and Keypad, shown below, is an optional accessory that can be purchased separately. It provides a convenient way of showing and adjusting the temperature set point or showing the actual temperature being sensed when the TC-36-25 RS485 is operating as a stand-alone controller. See the MP-2986 manual for further information.

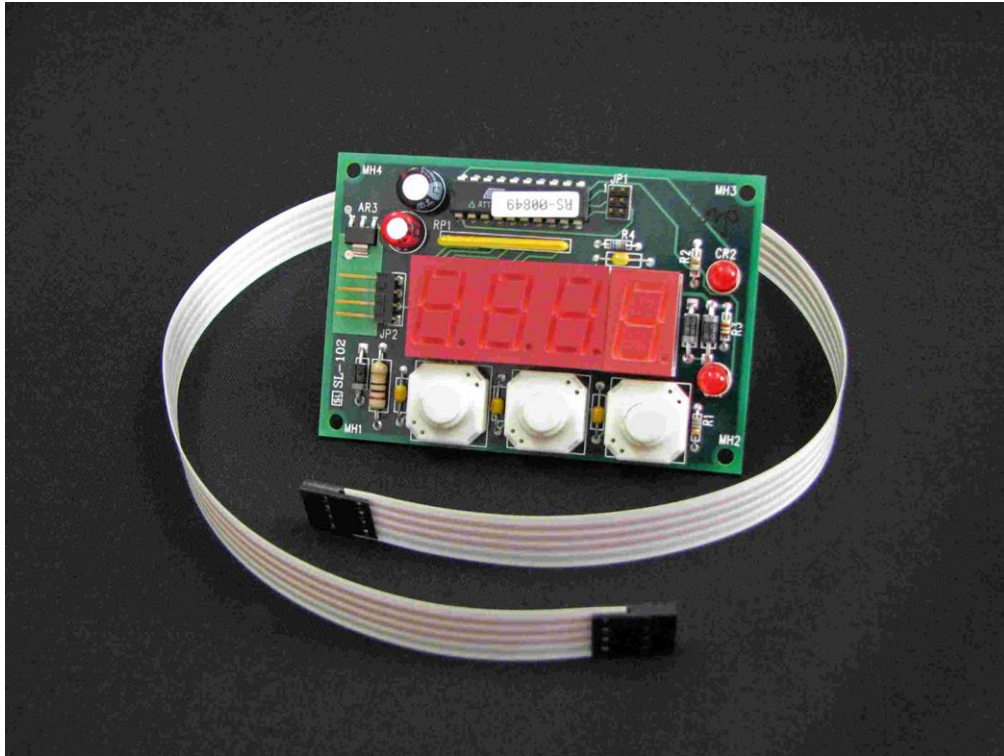

MP-2986 External Display and Keypad

Main Features

- RoHS compliant
- Operates as a stand-alone controller or with a computer monitor
- Bi-directional, solid-state H-bridge operation for both heating and cooling
- Can be configured to control both high and low voltage thermoelectric (TE) devices:
 - ✓ Single power supply configuration for TE devices with an input voltage range from (12 to 36) VDC
 - ✓ Dual power supply configuration for TE devices with an input voltage range is less than 12 VDC:
 - Controller-circuitry input voltage range from (12 to 36) VDC
 - TE device (H-Bridge) input voltage range from (0 to 36) VDC
- Maximum 25 A current rating, controls up to 900 W
- Soft-start features turns the output on slowly, over a one second period
- Over current shutdown that can be set in 2.5 A increments
- Open sensor and shorted sensor output shutdown with automatic restart
- Low Voltage shutdown protects the H-bridge when the control circuitry voltage is less than 12 VDC
- Pulse width modulation of output at 2700 Hz
- RS-485 communication protocol
- Computer programmable settings and monitoring
- Control temperature of $-20\text{ }^{\circ}\text{C}$ to $+100\text{ }^{\circ}\text{C}$ using thermistor supplied with controller
- Control temperature of $-40\text{ }^{\circ}\text{C}$ to $+250\text{ }^{\circ}\text{C}$ using optional thermistors
- Proportional (P), Integral (I) and Derivative (D) control that can be selected as P, PI, PD or PID; or Deadband (on/off) with an adjustable hysteresis
- Temperature resolution of $0.01\text{ }^{\circ}\text{C}$ or $0.01\text{ }^{\circ}\text{F}$
- Control stability of $\pm 0.01\text{ }^{\circ}\text{C}$ or $\pm 0.01\text{ }^{\circ}\text{F}$ (best case, when controlling a cold plate)
- Set temperature adjustable by several options:
 - Computer set via software
 - Remote potentiometer (customer supplied)
 - 0 mA to 20 mA current loop
 - 0 VDC to 5 VDC adjustable range
 - Differential temperature control (allows control to a programmable temperature difference above or below the temperature of the second thermistor, if used)
 - MP-2986 Display and Keypad (optional accessory)
- No computer programming experience required to use the communications software program (Supplied software is compatible with Windows 10/8/7)
- Command set is provided so programmers can create their own software interface or embedded controller applications
- Versatile alarm system:
 - Computer configurable alarms for 25 mA, with a compliance voltage up to 11 VDC
 - Alarm cancel: selectable via computer-software communication or remote contact closure

- The second sensor input is configurable as a heat-sink over-temperature shut-down
- Non-volatile memory retention of parameters (1,000,000 write cycles maximum; see command #34 in Appendix B for further details.)
- Operating temperature range of 0 °C to 60 °C, storage temperature range of -55 °C to +105 °C

Pulse-Width Modulated Power Output

The TC-36-25 RS485 requires a constant-voltage power supply to provide power for a thermoelectric (TE) device such as a TE cooling assembly or a Peltier (TE) module. The controller regulates the power to the TE device using a method called pulse-width modulation (PWM). With PWM, the power is rapidly switched “ON” and “OFF” at constant frequency (2700 Hz for this controller). This creates a square-wave “pulse” of power to the thermoelectric device. The “ON” time, or pulse width, can be varied to create an average output voltage (V_{average}) that is required by the TE device to maintain the set temperature.

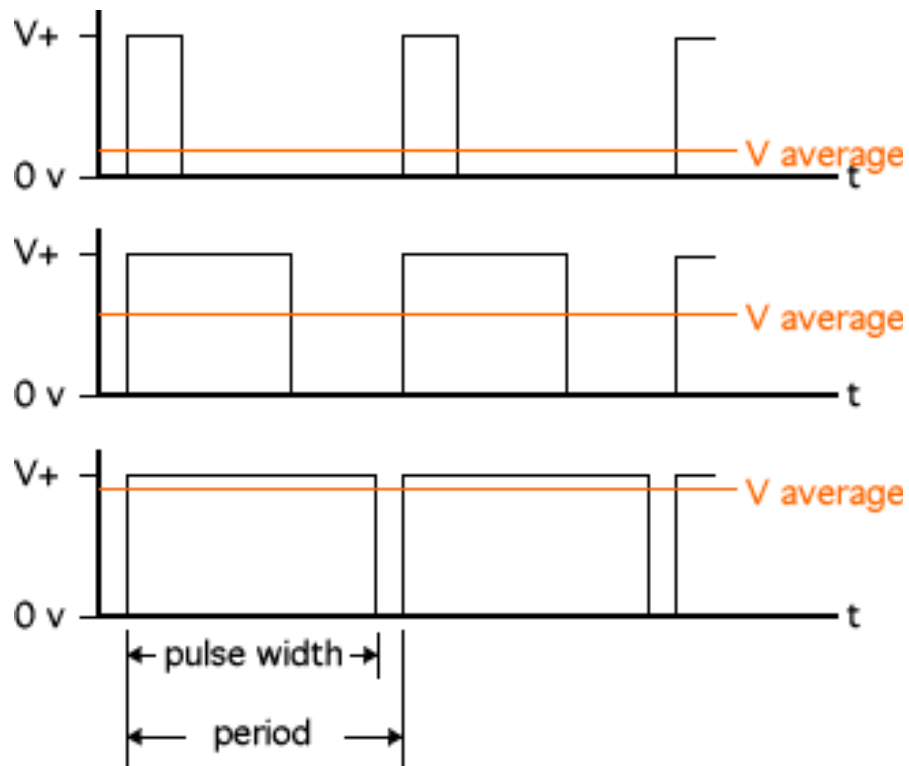

How Pulse-Width Modulation Works

The important advantage to PWM is that it does not cause the extreme temperature excursions that are experienced with a thermostatic control system. This helps to extend the life and reliability of the TE devices. Added benefits are that the controller does not generate a large amount of waste heat and it does not require a large heat sink.

Multiple Control Configurations

Depending on the input voltage required for the TE device, the TC-36-25 RS485 can be used with either one or two separate power supplies. When using one power supply, an input supply voltage ranging anywhere from (12 to 36) VDC is required to power both the controller and the TE device. The output voltage during the “ON” time is approximately equal to the input voltage.

When using two power supplies, one power supply, ranging anywhere from (12 to 36) VDC, can be used to power the controller itself, and a second power supply, ranging anywhere from (0 to 36) VDC, can be connected to the H-bridge of the controller. This second power supply allows the controller to control TE devices that must operate at a voltage less than 12 V. The self-contained H-bridge output transistors can deliver load currents from (0.1 to 25) A. (NOTE: consult appropriate installation instructions for power supply and heat sinking requirements for high current operation).

The controller tuning structure allows designation of a variety of control features:

1. The Computer Set Value provides for manual control of the output from 0% to $\pm 100\%$ of load power. This allows a remote device or computer to designate what output % the controller should deliver.
2. Proportional bandwidth (P) in degrees, Integral reset (I) in repeats per minute, and the Derivative rate (D) in minutes may be configured for P, PI, PD, or PID control.
3. Deadband control (on/off) with an adjustable hysteresis may also be selected. However, this control mode is not generally recommended with TE devices.
4. Differential temperature control is provided when two input sensing thermistors are used. The unit will control the differential between Input 2 (reference temperature) and Input 1 (actual system temperature).

A control temperature range of $-20\text{ }^{\circ}\text{C}$ to $+100\text{ }^{\circ}\text{C}$ is standard when using TE Technology’s supplied thermistor sensor probe (MP-3193) for the primary sense temperature. Other temperature ranges are available with optional thermistors.

The set point of the controller can be changed in a variety of ways by using either a computer, a remote set-temperature potentiometer, a (0 to 5) VDC signal, a (0 to 20) mA current loop, or the MP-2986 Display and Keypad accessory. A secondary thermistor can also be used for differential control (or it could be used for alarm condition sensing).

Two types of control output modes may be selected. This determines the direction of the current flow through the thermoelectric when heating is desired. This current flow may be from Wire Point WP1+ to Wire Point WP2-. Alternatively, this current flow may be reversed from WP2+ to WP1- as selected in the configuration menu.

Several alarm settings may be selected, some of which provide an output current of 25 mA for alarm signaling. The settings can be selected for no alarm function, tracking alarm, and fixed-value alarm. Alarm temperature values can be entered in the setup menu using the supplied software. The computer-controlled selection is available for additional embedded controller input/output options. The alarm setup menu also provides for selection of an alarm latching condition. The alarm sensor may be either the control temperature sensor or a secondary thermistor sensor.

The various alarms have the ability to determine the status of the output power to the thermoelectric cooler or auxiliary heater. The main output power may be maintained during an alarm condition or shut down, depending on the user’s setting.

Setup Instructions

1.0 Initial Setup



Portions of the temperature controller (the aluminum frame near the output transistors, for example) can exceed 60 °C during normal operating conditions. Temperatures greater than 60 °C can result in a hazard to the user. Use caution! Protect against accidental contact with hot surfaces.



If the temperature controller is to be used under conditions such that its surface temperatures could possibly exceed 60 °C, test the surface temperatures under the worst-case operating conditions of maximum ambient temperature and highest output current and voltage. If any portion of the temperature controller exceeds 60 °C place adequate guards around the temperature controller to prevent contact with any hot surfaces.



NOTE: the maximum allowable ambient temperature for the controller is 60 °C. Furthermore, the maximum allowable temperature of the controller base (underneath the transistor-mounting area) is 90 °C.

- 1.1 The TC-36-25 RS485 can run as a stand-alone controller, meaning that it can operate without the use of a computer. However, a computer with an RS485 port or an RS485 converter is required initially to set up various operating parameters.

Make sure the computer is **OFF** and the controller is **UN-POWERED**. Connect the RS-485 Communications Port from the controller (JP4) to the RS-485 port adaptor on the computer. Pin 1 of JP4 is the controller's (-), Pin 2 of JP4 is the controller's (+), and Pin 3 of JP4 is the controller's shield. If an RS485 converter is used to connect between the controller and the computer, the converter's Data (-) should be connected to JP4-2 and Data (+) should be connected to JP4-1.

The supplied resistor installed across JP4-1 and JP4-2 should **not** be removed if you have only one controller. If more than one controller is used, remove the resistor from all controllers but the farthest controller on the network. Connect the controllers in parallel with JP4-1 connected to JP4-1 and JP4-2 to JP4-2.

- 1.2 Attach the thermistor to the temperature-control location.

Generally, attaching the thermistor to the cold side of the TE device provides better control stability than locating it at the object, liquid, or air that is to be cooled/heated. However, in doing so, there will be a temperature difference between the TE device and the object, liquid, or air that is to be cooled/heated. The temperature set point can be adjusted to compensate for this temperature difference if necessary.

NOTE: When possible, it is recommended that at least 50 mm of the thermistor's wire be thermally connected to the cold side of the TE device. This can be accomplished by placing aluminum tape over the thermistor wires and attaching the wires and tape to the cold side of the cooler. If this is not done, the thermistor wires will be at a different temperature than the cold side and they will add or remove heat in the region of the thermistor, making the temperature reading **significantly less accurate** and thermal response time slower.

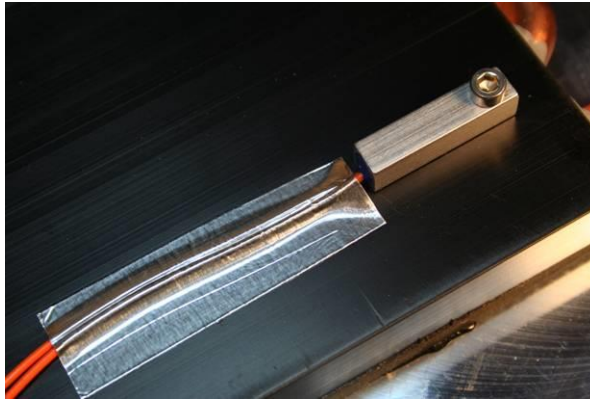

Thermistor attached to cold plate of cooler.

The standard thermistor supplied with the TC-36-25 RS485 is the MP-3193. Appendix C “*Thermistor Styles for TC-36-25*” shows dimensional data on the MP-3193 and other thermistor styles readily available as well as the corresponding temperature-resistance data (see also www.tetech.com for other thermistors that may be available). If you are using the MP-3193, it is recommended that you use thermal grease (such as TE Technology TP-1) between the thermistor and the surface to which it is mounted.

See also section 2.3 for further details on using thermistors with different resistance-temperature curves than the standard thermistor.

- 1.3 Connect the thermistor wire leads to terminals JP2-5 and JP2-6. The thermistor is non-polarized, so it does not matter which particular lead goes to which terminal. (See “*Controller Wiring Diagram*” for reference. The thermistor is indicated in the diagram as the ‘primary thermistor’.) You can lengthen the wire leads if necessary. The gauge of the wire is generally not important since the resistance of the wire is insignificant to the resistance of the thermistor.
- 1.4.0 The TC-36-25-RS485 can be used with either one or two separate power supplies, depending primarily on the nominal operating voltage of the TE device. If the maximum TE device input voltage is less than 12 V, then two power supplies must be used with the controller. In this case, one power supply is for the TE device, and the other power supply is for the controller itself (the microprocessor and associated electronics). Of course, just one power supply can be used for powering both the controller and the TE device provided that the TE device’s nominal operating voltage is within (12 to 36) V.



When using one power supply for powering the controller and the TE device together, the power supply input voltage is passed directly through the controller to the TE device during the “ON” pulse. The user should choose an input voltage that is required for the TE device and yet is also ≥ 12 V but ≤ 36 V. The controller could be damaged if it is operated outside this range.



When using two power supplies, the controller input power supply voltage must be ≥ 12 V but ≤ 36 V and provide a minimum of 200 mA current. The TE device power supply input voltage can be ≥ 0 V but ≤ 36 V, but it should be no greater than the rated input voltage for the TE device.



The TE device current rating should be no more than 25 A at the supplied input voltage regardless of whether you are using one power supply or using two independent power supplies. *NOTE: the maximum allowable ambient temperature for the controller is 60 °C. The maximum allowable temperature of the controller base (underneath the transistor-mounting area) is 90 °C. The controller might need additional heat sinking, depending on ambient conditions and how much current is being drawn by the TE device.*



The controller does have an internal 25 A fuse to limit current (Littelfuse PN: 0997025.WXN for controllers made after 1-JAN-2021 or Littelfuse PN: 142.6185.5256 for controllers made prior to 1-JAN-2021). This fuse provides a degree of protection to the controller. If the fuse needs replacing, be sure to compress the fuse holder tines to ensure the new fuse will have good electrical contact to the fuse holder. In any case, an external fuse, appropriately sized for protecting the TE device, should be connected between the controller and the TE device to prevent damage and to prevent injury to the user should an over-current condition occur with a TE device rated for less than 30 A. Alternately, a power supply with integral over current protection can be used if it is appropriately sized for protecting the controller/TE device.



When making a cooling system from a single TE device, the maximum operating voltage for that system is usually no more than 75% of the rated V_{max} of the TE module. The 75% rule is based on the TE module being thermally connected to a “good” heat sink; system modeling should be done to verify this rule is applicable though. If multiple TE modules are used in series or series-parallel combination, the V_{max} of the system will be approximately 75% of the rated V_{max} of each TE module multiplied by the number of modules in series. Applying a voltage greater than the system maximum will not necessarily damage the controller (unless voltage and/or current limits are exceeded), but the TE device could be damaged by overheating as a result.



Power supply and TE Device wire leads should be kept as short as possible to minimize electrical losses and reduce the likelihood of generating unwanted electromagnetic interference. Wire length must not exceed one meter. Use wires of a sufficient gage appropriate to the amount of electrical energy each wire is to carry. Wire insulation and size must also be appropriate to the ambient temperature and/or temperature of objects in contact with the wire. Wire leads supplied by TE Technology are for prototyping purposes and should be reviewed for appropriateness in the final application



Use protection devices to prevent hazardous conditions and/or damage to the load (e.g. cooling assembly, heater, et cetera) and other related equipment. Protection devices must operate independently of the temperature controller circuitry. Protection devices should be placed at all points on the load and related equipment where a hazardous condition can be detected. These protection devices should de-energize the TC-36-25 RS485, the load, and, as necessary, other related secondary equipment. It is further recommended that such devices require the user to remove and correct the root cause of a fault before allowing the TC-36-25 RS485, the load, and related equipment to be re-energized. Protection devices should include, but are not limited to:

- Fuses to prevent against electrical overloads,
- Over/under temperature thermostats to prevent against hazardous and/or damaging temperatures,
- Liquid flow meters to prevent against damage due to loss of coolant flow

The TC-36-25 RS485 controller (in conjunction with the standard and optional sensors) can detect under-temperature and over-temperature conditions as well as over-current conditions, and it can be configured to de-energize the load when such conditions are detected. However, hazards and/or risk of loss or damage to the load (e.g. cooling assembly, heater, etcetera), and/or secondary equipment could still occur if the temperature controller and/or sensors were to malfunction. Therefore, independent, redundant protection devices are recommended in addition to the safeguards provided by the temperature controller. For the purposes of this manual the temperature controller and sensors are not considered protection devices.

1.4.1 One Power Supply Operation:



Make sure the power supply is **NOT** energized while making electrical connections to the controller.



Power supply should provide voltage appropriate to the TE device.



If operating voltage is not between 12 V to 36 V, then two power supplies operation is required.

- a) Install jumper across JP6-1 and JP6-2 (default setup)
- b) Connect the constant DC voltage power supply (12 to 36) V to the controller:
 - Positive power supply terminal to WP3
 - Negative power supply terminal to WP4
- c) Do **NOT** connect the TE device to the controller at this time.
- d) See the “*Controller Wiring Diagram (Single Power Supply Setup)*” for further details.

1.4.2 **Two Power Supplies Operation:**



Make sure the power supplies are **NOT** energized while making electrical connections to the controller.

- a) Remove jumper across JP6-1 and JP6-2
- b) Connect the constant DC voltage controller power supply (12 to 36) VDC, 200 mA minimum to the controller:
 - Positive power supply terminal to JP6-2
 - Negative power supply terminal to JP6-3
 - Note: JP6 is a Molex connector, part number 22-23-2031
- c) Connect the constant DC voltage TE device power supply (0 to 36) VDC to the controller:
 - Positive power supply terminal to WP3
 - Negative power supply terminal to WP4
 - Install a 1.5 k Ω , 1 W (customer-supplied) resistor across the positive and negative power-supply terminals.
- d) Do **NOT** connect the TE device to the controller at this time.
- e) See the “*Controller Wiring Diagram (Two Power Supplies Setup)*” for further details.

- 1.5 Turn power on to both the computer and the power supply(s) (which in turn powers up the controller) and to the RS485 converter, if applicable. The on-board green LED will flash at a steady rate to indicate that the controller is energized correctly.



Do not mount the controller to a surface which is exposed to a source of heat, such as from electronics, machinery, or solar radiation.



Do not cover the controller with any object or otherwise restrict natural convection airflow around the controller. Doing so could cause the controller to overheat.



Do not mount the controller to an insulating surface. Doing so could cause the controller to overheat.



Do not operate the controller in such a manner as to cause the surface temperature of the circuit board or its frame to reach 70 °C. Otherwise the controller might be damaged and there might be a risk of fire as a result.



Do not allow the controller to be exposed to water (such as from dripping or leaking water lines or from water-vapor condensation if the surface temperature of the controller is below the dew point temperature).



Do not allow metallic dust/shavings to contact the controller electronics.

- 1.6 TE Technology offers the optional RS485 Adapter from our website (pictured below). It includes a pre-configured USB-COMi adapter, device drivers on a CD disk, USB cable, and a pre-wired 9-pin D-sub connector to connect the adapter to the temperature controller. If you are using the RS485 Adapter supplied by TE Technology, you can simply install the device drivers and connect the adapter to the computer and to the temperature controller (See *RS-485 Communications Connections* diagram).



RS-485 Converter

If you are using your own, customer-supplied USB-COMi adapter, you will need to configure the adapter to work properly with the controller. You will need to open up the adapter and adjust the jumpers as shown below:

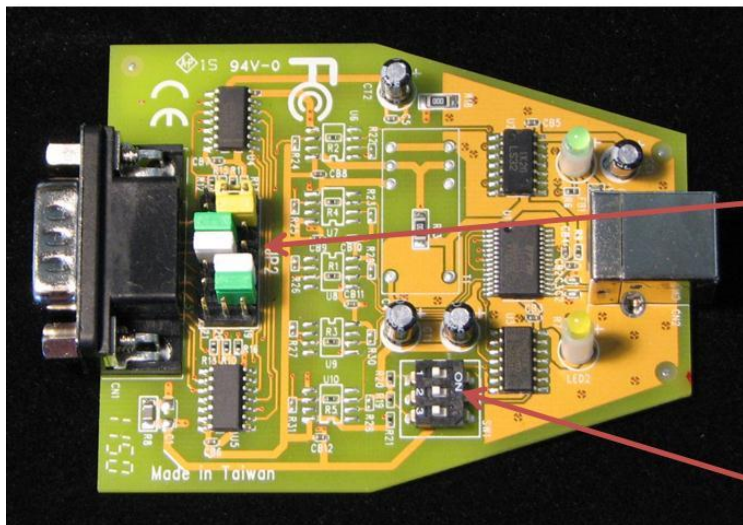

Row	Jumper	Pins
1-2-3	In	1-2
4-5-6	In	4-5
7-8-9	In	8-9
10-11-12	In	11-12
13-14-15	In	13-14
16-17-18	In	17-16
19-20-21	Out	

Switch	Jumper
1	Off
2	Off
3	Off

In addition, you will need to create your own 9-pin D-sub connector cable assembly. The connections are as follows:

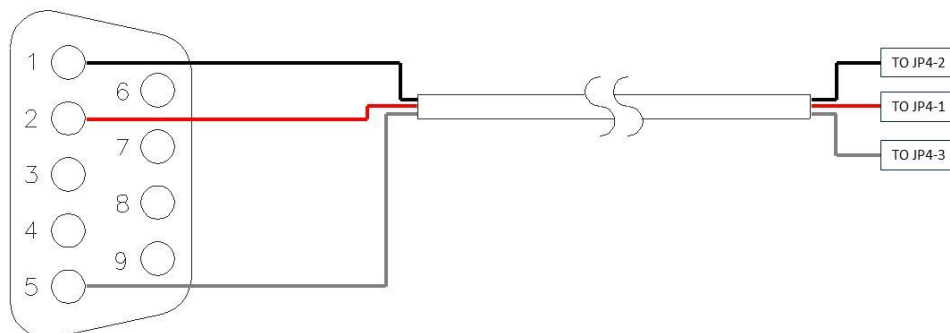

- 1.7 Insert the TC-36-25 RS485 software CD into the computer CD drive. To install the program, locate and run setup.exe on the CD, and follow the directions as displayed on the screen. The controller software itself is written in LabVIEW, so the LabVIEW runtime engine will also be installed.

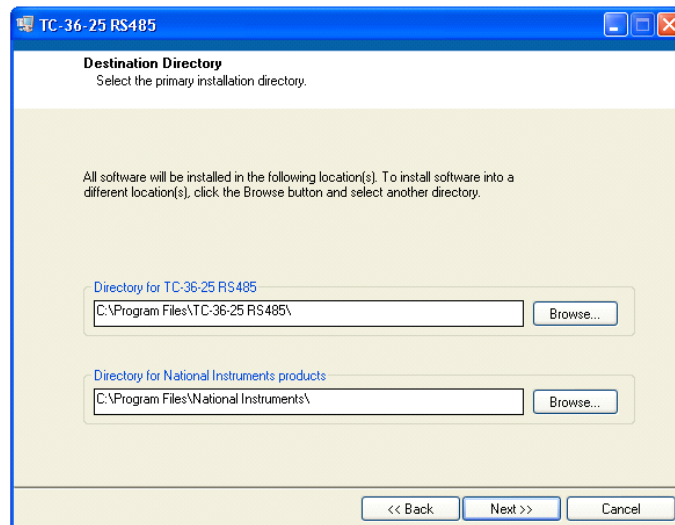
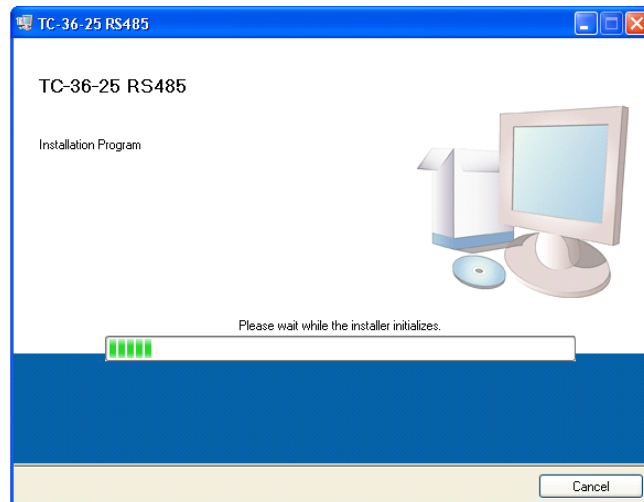

- 1.8 After installation run the program from the START – ALL PROGRAMS – TC-36-25 RS485 – TC-36-25 RS485 location.

2.0 Controller Setup

NOTE: If you plan to have more than one controller on the network, a unique address number must first be assigned to each controller to prevent communication errors. It is recommended that each controller be programmed with a unique address one at a time. Once done, the controllers can then be networked together.

If you plan on using only one controller on the network, then you can leave the default address as is. However, if you add another controller to the network, you must take steps to assign a different address to the new controller before using, or communication errors will result.

1. When only one controller will be on the network at a time:

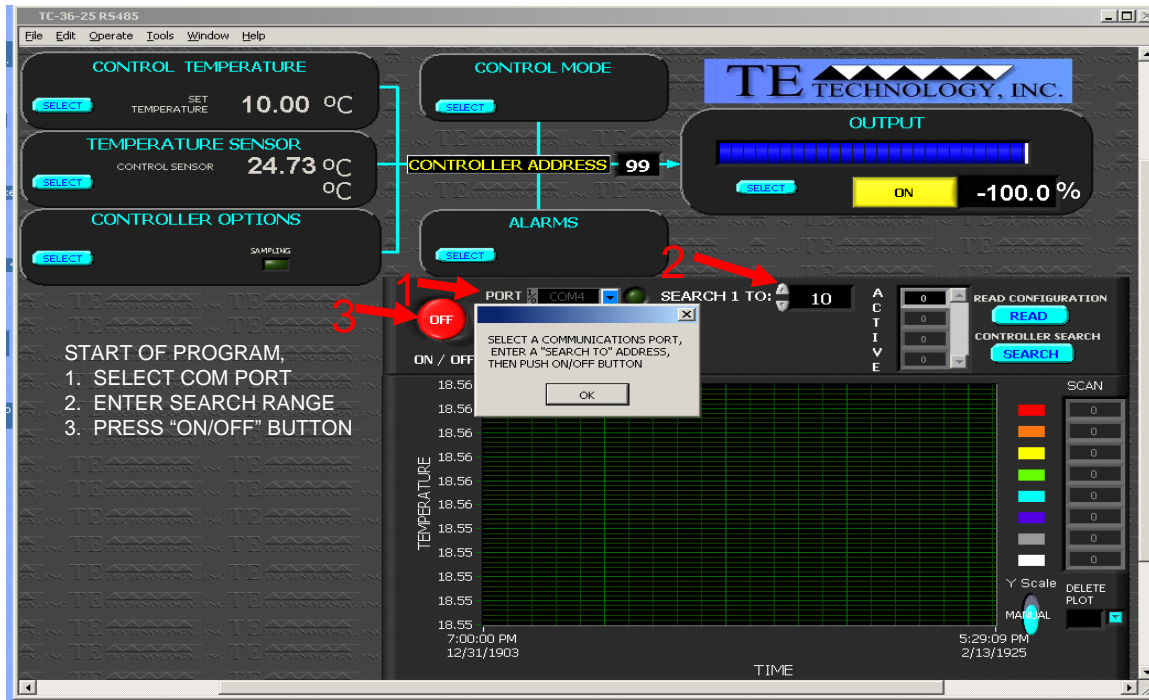

When the software is first started, it should prompt you to select the communications port to which the controller is connected. It should then prompt you to enter an address number corresponding to a range of controller addresses to search for. For new controllers, enter "98" [without the quotes] in the SEARCH ADDRESS RANGE (indicated below), and then click the blue START button. For an existing controller, enter the address for that controller. The software should then find and list the controller with its corresponding address (usually 98 for a new controller) in the CONTROLLER LIST.

2. When a controller is being added to an existing network:
Before applying power to the new controller and adding the controller to the network, place a jumper between JP2-1 and JP2-4. Also, if the new controller being added will be at the end of the network, make sure the new controller is the only one with a terminating resistor across JP4-1 and JP4-2. See *Multiple Controller Wiring (RS485) Diagram* for further details.

If the software is currently running the existing network, apply power to the new controller, and enter "99" [without the quotes] in the SEARCH ADDRESS RANGE. Then click the CONTROLLER SEARCH button to search for the new controller. When the jumper is added to the controller, it automatically assumes address 99. You can then assign a new address (see Section 2.4.6) to that controller (make sure EEPROM WRITE ENABLED is checked; see Section 2.4.1), remove power, remove the jumper, re-apply power, and communicate with the controller with the newly assigned address. You can also use this method if you have inadvertently assigned the same address to two or more controllers and need to reassign a new address.

2.1 ADDRESS

This is the address of the controller the software is currently communicating with. You can switch to a different controller (if on a multi-controller network) by entering in an address from the CONTROLLER LIST.

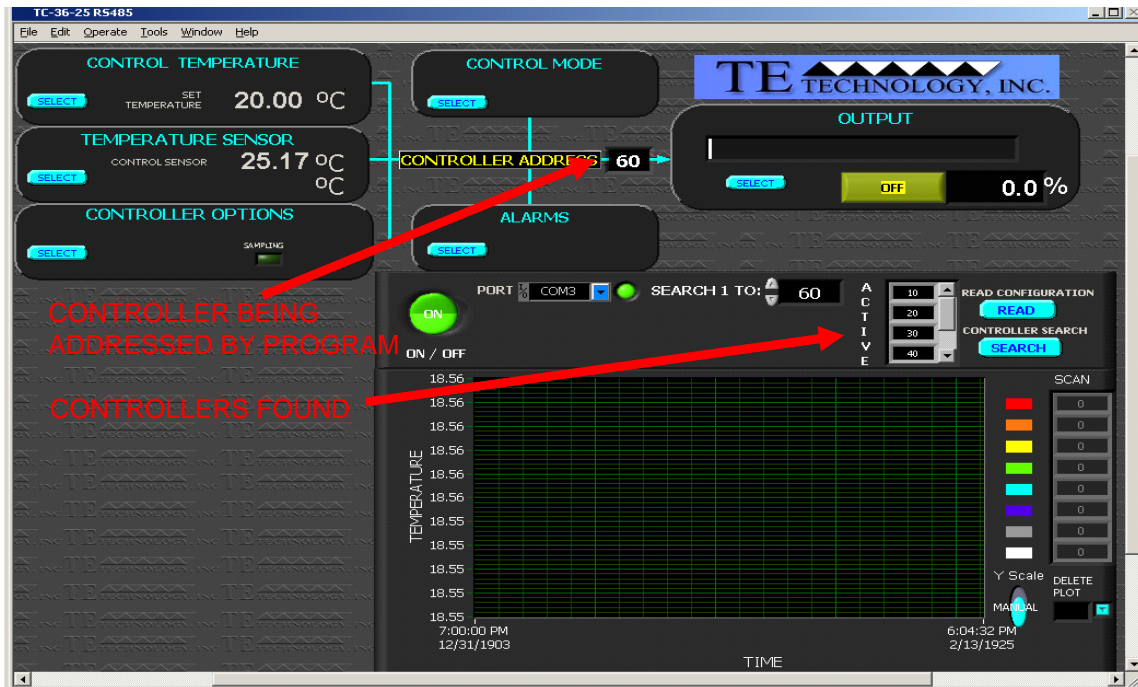

When you have switched to a new controller, click the blue READ CONFIGURATION button (lower right corner of the software); this will read the controller's current settings into the software. Any changes made to the software settings will only affect the controller whose address is shown in the ADDRESS box.

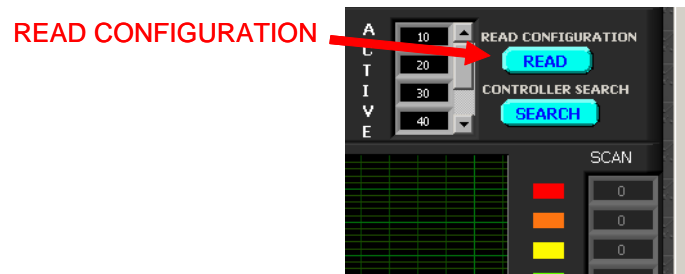

2.2 CONTROL TEMPERATURE

Click the SELECT button in the CONTROL TEMPERATURE section to display the CONTROL TEMPERATURE options.

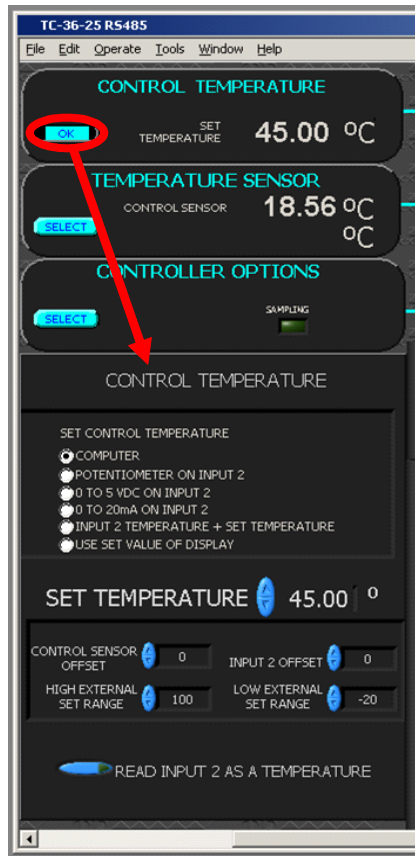

2.2.1 SET CONTROL TEMPERATURE BY:

The CONTROL TEMPERATURE can be set by various methods, as described below. The set temperature value can be anywhere within the range set in the EXTERNAL SET RANGE.

- COMPUTER:** This enables the controller to send a fixed percentage of output power. The values that can be entered in the SET TEMPERATURE box range from -5.11 to $+5.11$. This corresponds linearly to a fixed percentage of power output where -5.11 equals -100% power and $+5.11$ equals $+100\%$ power. If you selected HEAT WP+1 and WP2- in the OUTPUT section (See Section 2.7.1), then -5.11 corresponds to full-power cooling. The value is adjustable in 0.01 unit increments. See Section 2.5.1 for further details.
- POTENTIOMETER ON INPUT 2:** You can install a 5K ohm potentiometer on JP2 at pins 1, 2, and 3. The LOW EXTERNAL SET RANGE temperature and the HIGH EXTERNAL SET RANGE temperatures are mapped to the full counter-clockwise and full clockwise positions of the potentiometer, respectively. The set temperature scales linearly between 0 and 5K ohm set by the potentiometer.
- 0 TO 5VDC ON INPUT 2:** The set temperature can be changed by varying the voltage (up to 5 Vdc) applied across JP2-2(+) and JP2-1(-).
- 0 TO 20mA ON INPUT 2:** The set temperature can be controlled using a 20 mA current source. A 249 ohm resistor should be applied across pins JP2-1 and JP2-2.
- INPUT 2 TEMPERATURE + SET TEMPERATURE:** This can be used to maintain a constant temperature difference relative to the secondary thermistor. The secondary thermistor is installed at JP2-1, 2.
- USE SET VALUE OF DISPLAY:** The buttons on the optional, MP-2986 Keypad and Display Accessory are used for changing the set point temperature. The display must be enabled in order to use this feature (see Section 2.4.2).

2.2.2 SET TEMPERATURE

Enter the desired set temperature value in degrees Celsius. This temperature must be within both the range of the selected input sensor and the limits of low and high set ranges from the controller configuration setup. Also, verify that the cooler is capable of safely operating at the entered set temperature. This is particularly important if you are heating. While you can control to +100 °C using the standard thermistor, many TE devices are only rated for at most 70 °C.

2.2.3 CONTROL SENSOR OFFSET and INPUT 2 OFFSET

The temperature sensors on input 1 (primary CONTROL SENSOR thermistor) and input 2 (secondary thermistor) can be given separate offsets to correct for “errors” in the sensed temperature and the real temperature.

2.2.4 EXTERNAL SET RANGE

Use the HIGH EXTERNAL SET RANGE and LOW EXTERNAL SET RANGE to define the maximum and minimum allowable set temperature values when using an external input for setting the control temperature.

2.2.5 READ INPUT 2 AS A TEMPERATURE

Enabling this feature configures input 2 the same as input 1. That is, the controller assumes a secondary thermistor is installed. If you do not have a secondary thermistor installed, do not enable this feature; otherwise, the controller will assume a sensor error exists.



If you are using two thermistors with the controller, they must have the same resistance versus temperature characteristics. Also be sure that you have selected the correct sensor type. Otherwise a dangerous condition could exist because the actual temperature could be higher or lower than the temperature being interpreted by the controller.

2.3 TEMPERATURE SENSOR

The controller can accept several different types of negative-temperature coefficient thermistors. Available options correspond to various temperature-resistance curves for thermistors as shown in “*Temperature-Resistance Curves*” in the Appendix. Select the sensor type having the same temperature-resistance curve as the thermistor you intend to use with the controller:

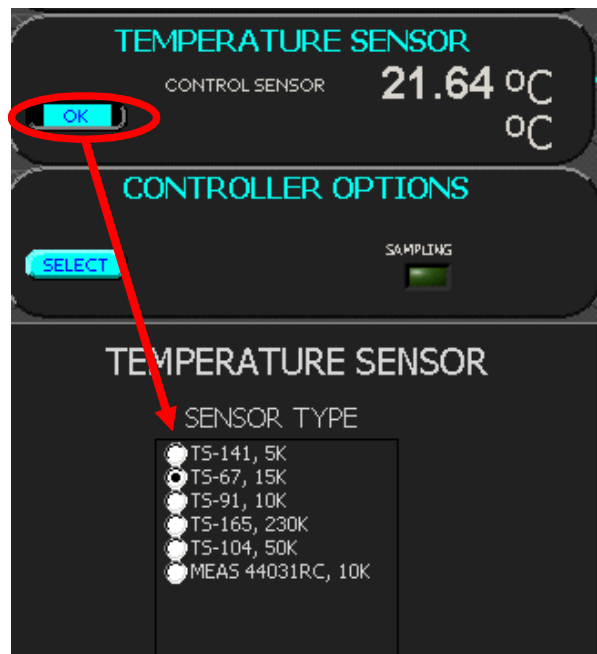

- a) TS-141 5K, control temperature range: -40 °C to +70 °C
- b) TS-67, TS132 15K, control temperature range: -20 °C to +100 °C
- c) TS-91 10K, control temperature range: -20 °C to +85 °C
- d) TS-165 230K, control temperature range: +25 °C to +250 °C
- e) TS-104 50K, control temperature range: 0 °C to 150 °C
- f) MEAS 44031RC 10K, control temperature range: 0 °C to +70 °C

NOTE: Select TS-67, TS132 15K when using the supplied MP-3193 sensor or one of the other sensors listed in Appendix C “*Thermistor Styles for TC-36-25.*” This will provide a control range of -20 °C to +100 °C. However, remember that depending on the type of TE device you have, it might not be suitable for operation at temperatures greater than 70 °C.

If you have an existing 10K Ohm thermistor, the TS-91 10K might be equivalent. The TS-91 10K is equivalent to the 10K ohm thermistor; curve “B” from Measurement Specialties, Inc.

Contact TE Technology if you need a sensor that uses a temperature scale different from the “TS-67, TS132 15K”.



If you are using two thermistors with the controller, they must have the same resistance versus temperature characteristics. Also be sure that you have selected the correct sensor type. Otherwise a dangerous condition could exist because the actual temperature could be higher or lower than the temperature being interpreted by the controller.

2.4 CONTROLLER OPTIONS

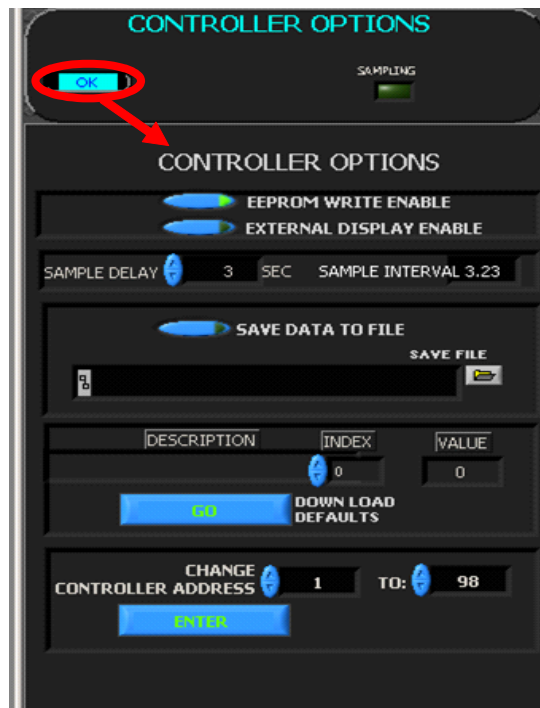

2.4.1 EEPROM WRITE ENABLE

Upon a power-up or reset condition, the controller performs an initialization of all command variables that have write commands. The controller transfers the last values stored in non-volatile memory (EEPROM) to appropriately referenced static RAM locations. This action is performed so that the controller can run faster (RAM is faster than ROM). This also allows the controller to run as a stand-alone controller, separate from the computer.

When this is turned on, any changes to software settings at run time are stored in EEPROM as well as RAM. The values can then be recalled upon a power-up or reset condition. The maximum number of writes to an EEPROM location is 1,000,000. So, you may want to keep this setting off most of the time in order to avoid this limit.

When this is turned off, any changes to software settings are only stored in RAM. No settings are saved to EEPROM. This setting gives you the ability to change run-time settings without changing desired power-up settings. This allows you to make unlimited changes to run-time settings without having to write to EEPROM.

2.4.2 EXTERNAL DISPLAY ENABLE

The optional MP-2986 display will display the set temperature and input 1 (primary thermistor) reading if this is enabled.

2.4.3 SAMPLE DELAY and SAMPLE INTERVAL

Enter a SAMPLE DELAY to set an *estimated* time interval between when data samples are taken. Because there can be up to 255 controllers communicating on the same network, the sample time interval set in SAMPLE DELAY can be different than the actual sample interval. This varies with the number of controllers in the network, alarm conditions, number of controllers being scanned and if data is being saved. The SAMPLE INTERVAL displays the actual sample period.

2.4.4 SAVE DATA TO FILE

Each sample can be saved to a file in the SAVE FILE box. The data saved is the controller address, sample time, and the temperature sensed on input 1 (primary thermistor) for each controller being scanned.

2.4.5 DOWNLOAD DEFAULTS

The DOWNLOAD DEFAULTS section is used to reprogram all settings in the controller with the factory defaults. The index control can be used to view the default settings. Clicking the GO button will program the controller in the ADDRESS box with these settings.

2.4.6 CHANGE CONTROLLER ADDRESS

The allowable address range is from 1 to 255, but not 99. Addresses 0 and 99 are reserved. Do **not** program a controller with a reserved address. A unique address number needs to be assigned to each controller on a multi-controller network to prevent communication errors.

NOTE: Programming two or more controllers with the same address will cause communication errors. If this occurs, place a jumper between JP2-1 and JP2-4 in one of the controllers to set the address to 99 (as described previously in Section 2.0). Alternatively, remove one of the controllers from the network, and reprogram it separately with a unique address before returning it to the network.

2.5 CONTROL MODE

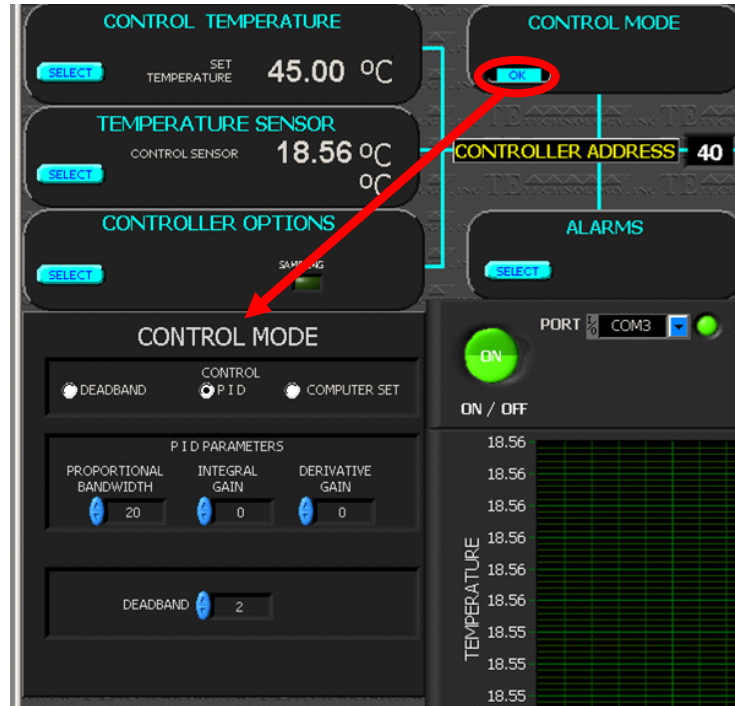

2.5.1 CONTROL MODE

The CONTROL MODE determines how the controller will attempt to obtain set point stability:

- PID CONTROL:** The controller uses proportional/integral/derivative control. When this mode is selected, the temperature controller compares the actual temperature to the set temperature and automatically adjusts the output power accordingly. The output power is a function of the primary temperature sensor feedback and the PID PARAMETERS (Section 2.5.2).
- COMPUTER CONTROL:** This enables the user to select a constant, fixed-duty-cycle output (a fixed percentage output). This applies when the COMPUTER option under the SET TEMPERATURE BY section is selected; see section 2.2.1 for further details.)
- DEADBAND CONTROL:** This causes the controller to behave much like a mechanical thermostat. DEADBAND CONTROL should not be used unless care is taken to prevent the TE device from being damaged by excessive thermal cycling.

2.5.2 PID PARAMETERS

PROPORTIONAL BANDWIDTH:

The acceptable bandwidth values that may be entered are (1 to 100) degrees.

The proportioning bandwidth is the temperature span over which the output power is proportioned from -100% to +100%. The bandwidth is centered about the temperature set point, and once set the proportional output will vary as the actual temperature moves through the bandwidth range. That is, the controller output is +100% at the end of the bandwidth range above the set point, it decreases to 0% power as it reaches the set point, and then reverses to -100% as it reaches the end of the bandwidth range below the set point.

For example, suppose the controller is being operated in the cooling mode, the set point is 10.0 °C, and the bandwidth is set to 5 °C (with INTEGRAL GAIN and DERIVATE GAIN both set to zero). The controller will be at +100% output until the temperature cools to 12.5 °C. Power then starts to proportionally decrease as the sensor temperature is cooled below 12.5°C. The power will be reduced to 0% when the sensor is at 10.0 °C. Finally, the power will reverse polarity and proportionally increase to -100% if the sensor temperature decreases to 7.5°C.

If the bandwidth is set too narrow, the temperature will oscillate around the set point. If the bandwidth is too wide, the controller will be slow to respond or may never reach set point.

INTEGRAL GAIN:

The acceptable values that may be entered are (0.00 to 10) repeats per minute.

With just proportional control, the controller's output is, by definition, 0% when the actual temperature reaches the set temperature. Because some non-zero output power level is almost always required to reach the set point, using **only** proportional control will not allow the controller to maintain a desired set point. Therefore, introducing an integral gain allows for an output amount other than 0% when the actual temperature reaches the set temperature. It essentially shifts the output power to the average level required to maintain the desired set point.

For example, suppose the set temperature is 10.0 °C, the bandwidth is set to 5 °C, and the controller settled to a constant 11.2 °C (corresponding to 48% power with only the proportional bandwidth active).

- In this case the "error", or difference in temperature between the set point and actual temperature, is 1.2 °C.
- From the example in section 3.3 we know that the proportional output will change by 40% for every 1 °C change in the error (this is bandwidth gain of 40 % per °C).
- Let's assume the integral gain is activated by changing its setting from "0" to "1 per minute".

The integral function will now ramp the output at a rate determined by the error signal, the proportional bandwidth gain, and the integral gain. The rate is determined by multiplying the error, the bandwidth gain, and the integral gain. In this case, if the integral control is set to 1 repeat per minute, the controller will increase the output power at a rate of 48% per 1 minute.

$$\left(40\%/\text{°C}\right)\left(1.2\text{°C}\right)\left(\frac{1}{\text{min}}\right) = 48\%/\text{min}$$

This output % is updated continuously. Of course, the maximum output is limited to +100% and the minimum is limited to -100%.

If the integral gain is set too high, the temperature will oscillate. If integral control is set too low, it will take a long time for the temperature to settle to steady state.

DERIVATIVE GAIN:

The acceptable values that may be entered are (0.00 to 10) cycles per minute.

The derivative gain senses the rate of change of the temperature and allows the controller to anticipate the power needed to compensate for rapid changes in system loading. This term is generally used only on very sluggish systems or where very quick response is necessary. It works in a way similar to the integral gain, but acts upon change in error signal and not the actual error signal.

The method of determining the proper parameters for proportional bandwidth, integral gain, and derivative gain is described in Section 3.0.

DEADBAND

The controller can be set to turn on and off by either rising or falling temperatures where no heating or cooling takes place. This band is expressed in degrees, and the acceptable values that may be entered are 0.1 to 100. This setting is only utilized when CONTROL TYPE is set to DEADBAND CONTROL.

2.6 ALARMS

The alarm status and controls are viewed and set in this section.

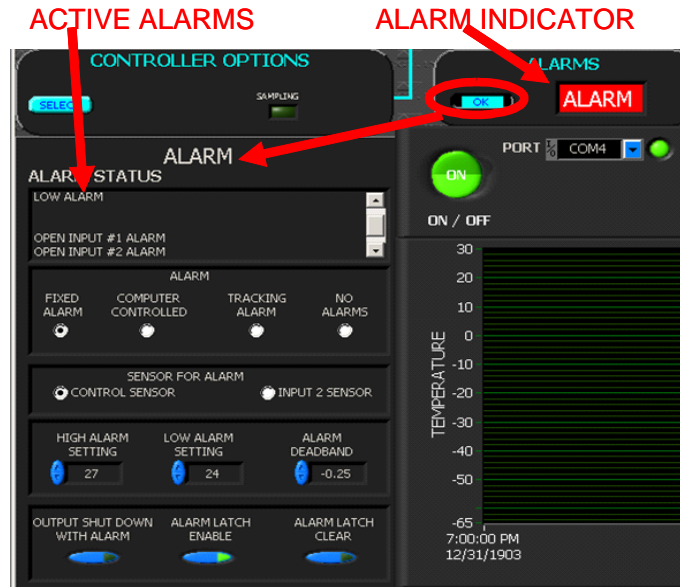

2.6.1 ALARM STATUS

Any alarm that occurs in the controller whose address is in the address box will be displayed in the alarm status box. When there is an active alarm the ALARM indicator light will blink.

The possible alarm conditions are:

HIGH ALARM: the temperature is greater than the HIGH ALARM SETTING

LOW ALARM: the temperature is lower than the LOW ALARM SETTING

COMPUTER CONTROLLED ALARM: the user has activated the alarm relay via the software

OVER CURRENT DETECTED: the TE device attempted to draw more current than allowed the OVER CURRENT SET

OPEN INPUT1: there is a problem with the primary temperature sensor

OPEN INPUT2: there is a problem with the secondary temperature sensor

DRIVER LOW INPUT VOLTAGE: the controller does not have a high enough voltage to properly operate

2.6.2 ALARM MODE

- FIXED VALUE ALARMS: permits the setting of a fixed, absolute temperature either above or below the sensor temperature or both.
- COMPUTER CONTROLLED: provides for user activation of the alarm relay via the computer software. This is turned on and off with the ALARM LATCH ENABLE button.
- SET TRACKING ALARMS: allows an alarm to be set with respect to the set temperature. It will move accordingly with a change of the temperature setting. This option can be used for a high alarm, low alarm, or both settings.
- NO ALARMS PICKED: no alarm condition will be monitored.
- The "Expansion Connector Wiring Diagram" shows how customer-supplied LED's can be installed to externally signal various alarm conditions as well.

Associated with the ALARM TYPE configuration are the HIGH ALARM SETTING box, LOW ALARM SETTING box, and the ALARM DEADBAND box. If an alarm type has been selected, enter the desired high and low temperature values that you want to have trigger an alarm condition. The ALARM DEADBAND option sets the hysteresis of the alarm values from 0.1 degrees to 100 degrees.

2.6.3 SENSOR FOR ALARM

- CONTROL SENSOR: if this is selected, the primary sensor is used for monitoring alarm conditions.
- INPUT 2 SENSOR: if this is selected, the secondary sensor is used for monitoring alarm conditions. This requires that a secondary thermistor be installed, and a potentiometer or voltage/current levels cannot be used for adjusting the set point temperature.

2.6.4 OUTPUT SHUT DOWN WITH ALARM

- a) If this is turned off, the controller will continue to supply power to the TE device regardless of any alarm condition.
- b) If this is turned on, the controller will shut off power output to the TE device when an alarm condition exists.

2.6.5 ALARM LATCH ENABLE:

If the ALARM MODE is set for FIXED VALUE ALARMS or SET TRACKING ALARMS, then the ALARM LATCH ENABLE button behaves as follows:

- a) If ALARM LATCH ENABLE is turned off, the controller will automatically reset to a non-alarm state if the alarm condition self-corrects.



If OUTPUT SHUT DOWN WITH ALARM is turned on, and the alarm condition self-corrects and is recurring, and the ALARM LATCH ENABLE is turned off, the TE device could be damaged by thermal fatigue stress imposed by repeated, long-term power cycling.

- b) If ALARM LATCH ENABLE is turned on, the controller will maintain the alarm condition until it is manually cleared. If an alarm condition exists, root cause should be determined and the condition corrected first. The alarm latch can be reset by clicking the ALARM LATCH CLEAR button or by electrically shorting the Alarm Cancel pin, JP5-5 to the circuit ground pin, JP5-4.

If the ALARM MODE is set to COMPUTER CONTROLLED, then the ALARM LATCH ENABLE button behaves as follows:

- c) If turned on, the controller behaves as if an alarm condition exists.
- d) If turned off, the controller behaves as if an alarm condition does not exist.

2.6.6 ALARM LATCH CLEAR

The alarm latch can be reset by clicking the ALARM LATCH CLEAR button or by electrically shorting the Alarm Cancel pin, JP5-5 to the circuit ground pin, JP5-4.

2.7 OUTPUT

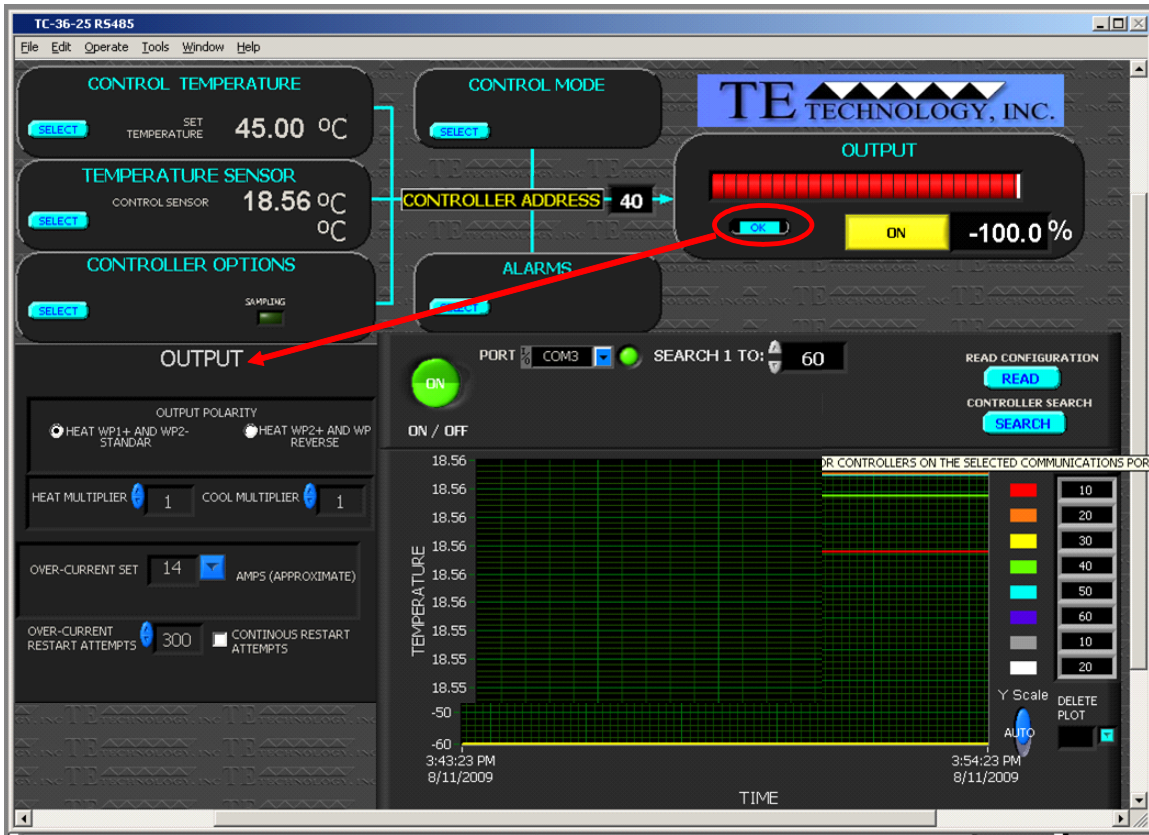

OUTPUT ON/OFF:

- a) OFF: output power to the TE device is shut off.
- b) ON: output power to the TE device is enabled and the controller will begin controlling to the set point temperature (if possible).

For the initial setup, (prior to connecting a TE device), turn output to OFF.

2.7.1 OUTPUT POLARITY HEAT: WP1+ AND WP2- or HEAT WP2+ AND WP1-

This selection establishes the polarity for the heating mode of the thermoelectric cooler. It allows you to reverse the current flow in the TE device without having to change the wiring.

NOTE: For TE Technology's standard products, the TE+ (red) wire should be attached to WP2 and the TE- (black) wire should be attached to WP1 as shown in the "Controller Wiring Diagram." The OUTPUT POLARITY should then be set to HEAT WP1+ and WP2-. Again though, do **NOT** connect the TE device at this time.

2.7.2 HEAT SIDE MULTIPLIER

This is a 0.00 to 1.00 numerical multiplier that compensates for the non-symmetrical response of the thermoelectric cooler between the heat and cool modes. When the controller is in heating mode it takes the computed PID output power value and multiplies it by this multiplier to derive the actual output level. Setting the value to 0 makes the controller a "cool only" controller.

2.7.3 COLD SIDE MULTIPLIER

This is a 0.00 to 1.00 numerical multiplier that compensates for the non-symmetrical response of the thermoelectric cooler between the heat and cool modes. When the controller is in cooling mode it takes the computed PID output power value and multiplies it by this multiplier to derive the actual output level. Setting the value to 0 makes the controller a "heat only" controller.

2.7.4 OVER CURRENT SET

This selects the level at which the over-current protection for the TE device turns off the output power. This level is adjustable in 2.5 A increments, and the allowable levels range from 0 A to 40 A. The controller will automatically attempt to restart the output (either continuously or a fixed number of times) per the conditions set as described in Section 2.7.5. During the restart attempts, the output will still be shut down each time if the over-current level is reached again. If a fixed limit of attempts is reached the output will be disabled until a “latch clear” signal is sent (see Section 2.6.6) or the controller is turned off and then on again.



NOTE: THIS IS NOT AN ANALOG CURRENT LIMIT FEATURE!

The over-current value is approximate; the actual current value the controller shuts off at may differ by 3 A or more from the selected over-current level. Also, it is normal to have an output current surge when the direction of current flow is instantaneously reversed to a TE device that has a temperature difference established across it. When this happens, the “apparent electrical resistance” of the TE device is lower because the Seebeck back-voltage does not immediately reverse polarity. The reversal of current will eventually reverse the temperature difference across the TE device (and then its Seebeck back-voltage will likewise change polarity). As the temperature difference reverses, the current will revert back down to a steady-state level.

2.7.5 OVER-CURRENT RESTART ATTEMPTS / CONTINUOUS boxes

This sets the number of restarts the controller will attempt. Selecting the CONTINUOUS box provides an infinite number of restarts. If a fixed limit of attempts is reached, the output will be disabled until a “latch clear” signal is sent or the controller is turned off and then on again.

2.8 DISPLAY SECTION

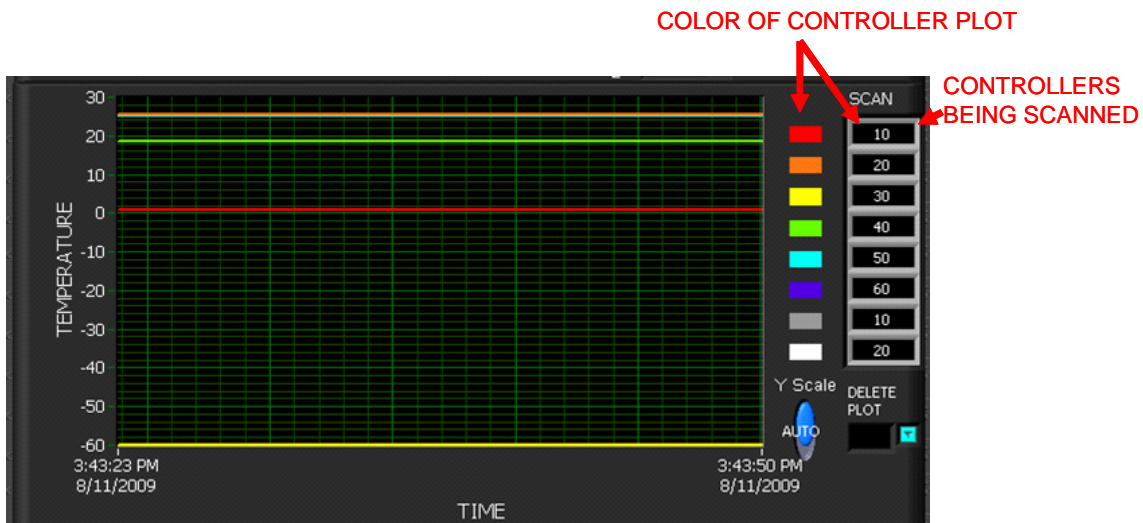

The DISPLAY SECTION contains the graphical display of samples taken of the controllers in the SCAN LIST. The SCAN LIST contains the addresses of controllers to be sampled and is created by entering up to eight addresses separated by commas. The PLOT LEGEND is automatically created from the SCAN LIST and depicts each controller sampled with a different color. The graph is auto scaled $\pm 10\%$ of the minimum and maximum readings. More graph options are available by right clicking on the graph.

3.0 FINAL SETUP—CONTROLLER TUNING

The tuning method follows the Ziegler-Nichols closed-loop tuning principals. The controller will first be set to a high proportional bandwidth setting with no integral or derivative function (integral gain and derivative gain = 0). Then, the bandwidth is gradually decreased until the temperature approaches set point and a small, sustained oscillation in temperature is observed. The other tuning parameters are then readjusted based on the time period of the temperature oscillation (natural period) and the proportional bandwidth needed to cause this oscillation.



Improper tuning of this temperature controller can lead to excessive thermal cycling and/or overheating of the thermoelectric device, either of which are known to reduce the lifetime of any thermoelectric device. Care should be taken to prevent the temperature of the TE device from going beyond the range specified by the device manufacturer. Care should also be taken so that any thermal cycling of the TE device is a result of changes in the controller's set-point temperature and not instability at a given set point due to improper selection of the tuning variables.

- 3.1 Connect **ONLY** the TE device to the controller (fans should not be connected to the controller):
 Positive TE device terminal to WP2
 Negative TE device terminal to WP1



TE Technology's standard thermoelectric cooling assemblies (TCA) have at least one fan on the heat sink. The standard configuration has the thermoelectric modules and fan(s) wired to a terminal block with jumpers across the terminals so that the fans and modules are connected in parallel. However, this configuration is applicable only when applying power directly from the power supply. When using the TCA with the temperature controller, the jumpers **MUST** be removed so that the controller is controlling power only to the thermoelectric modules. There must be no electrical connection between the fans and the modules; fans must be connected directly to the power supply, not to the controller. **The controller will be damaged if this is not followed.** See the cooler manual for further details, but the picture below shows the basic setup.

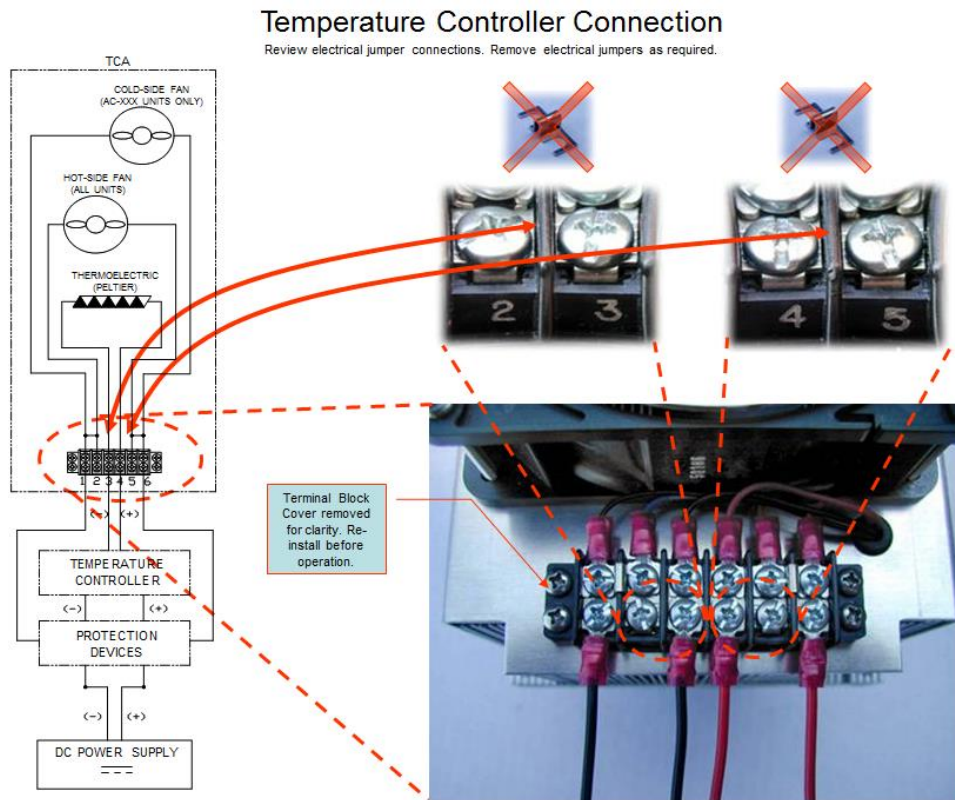

NOTE: Generally there is approximately a 0.5 to 1.3 V drop from the power supply to the TE device. You might need to adjust the power supply accordingly to ensure full power is delivered to the TE device when needed.

Next, click the ON/OFF button in the OUTPUT section to turn on output power (again, make sure the set point temperature is appropriate for the TE device before applying output power). The controller will begin to send output power to the TE device.

3.2 Enter the following parameters:
PROPORTIONAL BANDWIDTH: 20
INTEGRAL GAIN: 0
DERIVATIVE GAIN: 0

3.2.1 Allow the TE device to reach steady state. Incrementally reduce the bandwidth setting, allowing the controller to reach steady-state at each increment, until the temperature just begins to oscillate. At this point, the bandwidth is too small. Note the bandwidth setting that just caused the system to oscillate and note the time period of oscillation in minutes. The time period will be used later for determining the integral gain and derivative gain settings.

NOTE: The system temperature will likely begin to oscillate before reaching the set point temperature. This is normal.

3.2.2 Multiply the current proportional bandwidth setting by 2.2, and enter it as your new PROPORTIONAL BANDWIDTH setting. The temperature should stabilize and maintain a steady temperature near the set point.

3.2.3 The integral gain is calculated as follows: $I = 0.54/T$ where I is the integral gain, and T is the time period, in minutes, determined in section 3.2.1. Enter this value into the INTEGRAL GAIN.

For example, suppose the system's period of oscillation with the appropriately set proportional bandwidth was 75 seconds (1.25 minutes). The suggested integral gain is therefore:

$$I = 0.54/1.25 \text{ minutes} = 0.43 \text{ repeats/minute}$$

3.2.4 The derivative gain is often times difficult to apply and might cause more trouble than it is worth. If you are not experienced in process control, you may be better off leaving the DERIVATIVE GAIN set to zero.

If you decide to use derivative gain, the other values should be adjusted first.

- a) Instead of multiplying the initial bandwidth setting by 2.2, multiply it by 1.7, and enter this as the new PROPORTIONAL BANDWIDTH setting.
- b) Calculate the integral gain as follows: $I = 1.2/T$, and enter this into the INTEGRAL GAIN setting.
- c) Calculate the derivative gain as follows: $D = 0.075 \times T$, and enter this into the DERIVATIVE GAIN setting.

Setup of the TC-36-25 RS485 is now complete. However, the proportional, integral, and derivative settings are approximate settings and might need further minor adjustments.

You might also want to save your settings to EEPROM for future recall (see section 2.4.1)

Controller Wiring Diagram: TC-36-25 RS485 with One Power Supply Setup

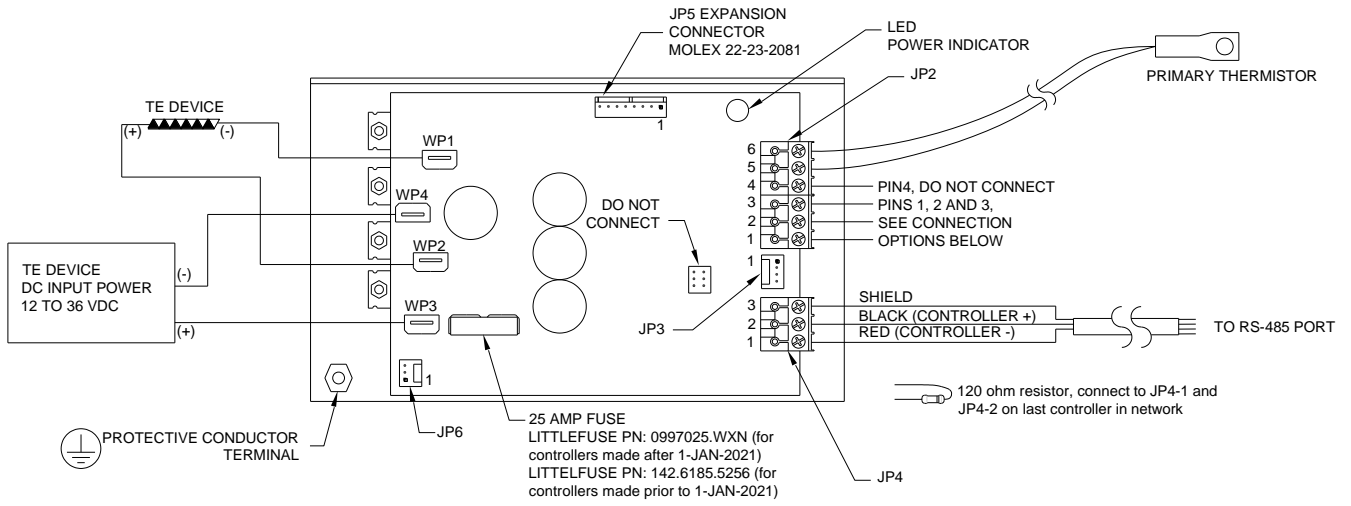

NOTE: 1. WP1, WP2, WP3, AND WP4 ARE 6.35 mm (.25 inch) QUICK CONNECT TERMINALS
2. SINGLE POWER SUPPLY SETUP: INSTALL JUMPER ON PINS 1 AND 2 OF JP6 (DEFAULT CONDITION)

OPTION 1 Proportional Signal for Adjusting Set Point

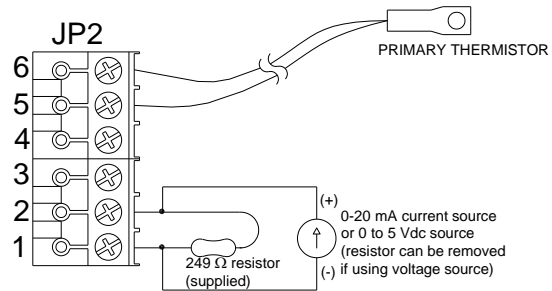

OPTION 2 Variable Resistance for Adjusting Set Point

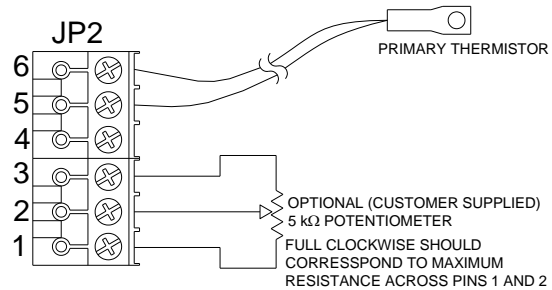

OPTION 3 Second Thermistor for Differential Control or for Sensing Over-temperature Condition

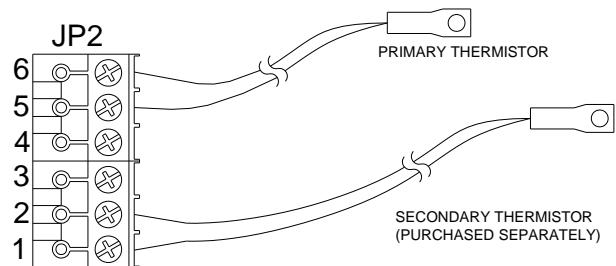

Controller Wiring Diagram: TC-36-25 RS485 with Two Power Supplies Setup

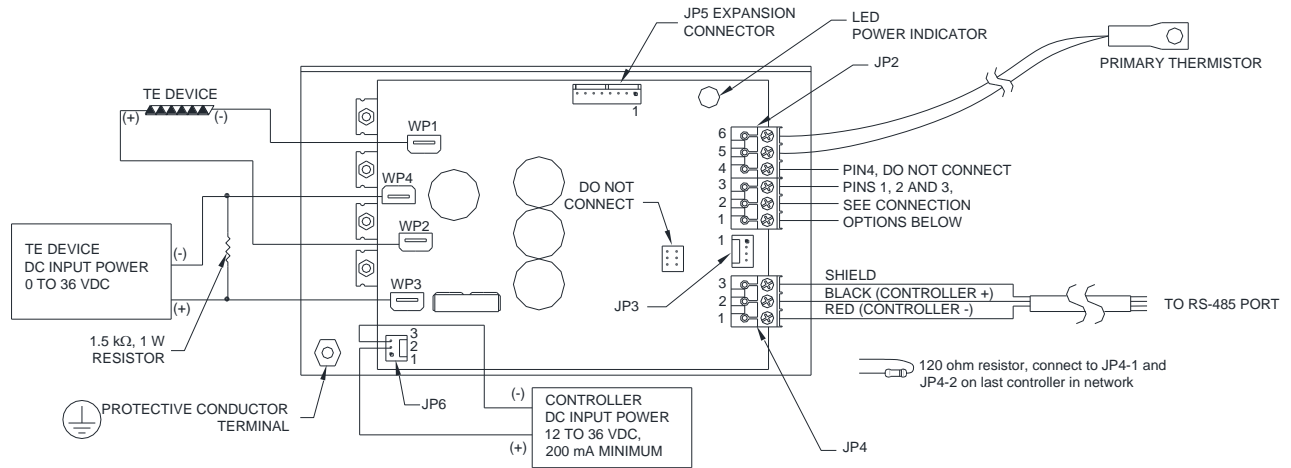

- NOTE: 1. WP1, WP2, WP3, AND WP4 ARE 6.35 mm (.25 inch) QUICK CONNECT TERMINALS
 2. TWO POWER SUPPLIES SETUP: A. TE DEVICE POWER SUPPLY CONNECTS TO WP3(+) AND WP4(-)
 B. CONTROLLER POWER SUPPLY CONNECTS TO JP6-2(+) AND JP6-3(-) (REMOVE JUMPER FROM JP6)
 JP6: MOLEX PN: 22-23-2031
 3. INSTALL 1.5 kΩ, 1 W RESISTOR (customer-supplied) ACROSS WP3(+) AND WP4(-).

OPTION 1 Proportional Signal for Adjusting Set Point

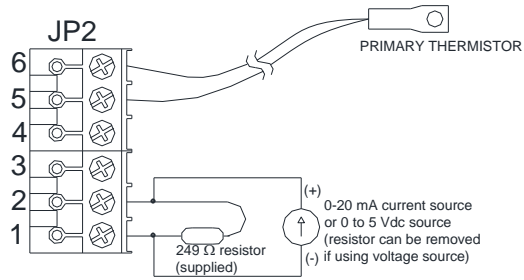

OPTION 2 Variable Resistance for Adjusting Set Point

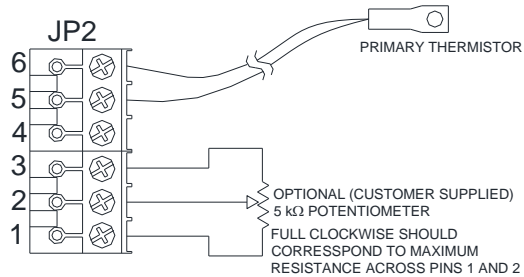

OPTION 3 Second Thermistor for Differential Control or for Sensing Over-temperature Condition

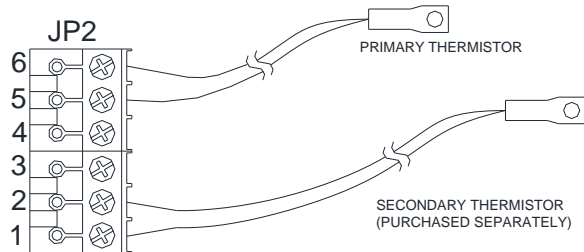

Expansion Connector Wiring Diagram

Note: The 25 mA current source is a true current source. Maximum compliance voltage is approximately $V+$, the input voltage to the temperature controller. No external current limit resistors are needed for the LED. The LED must be capable of being driven with a 25 mA continuous current.

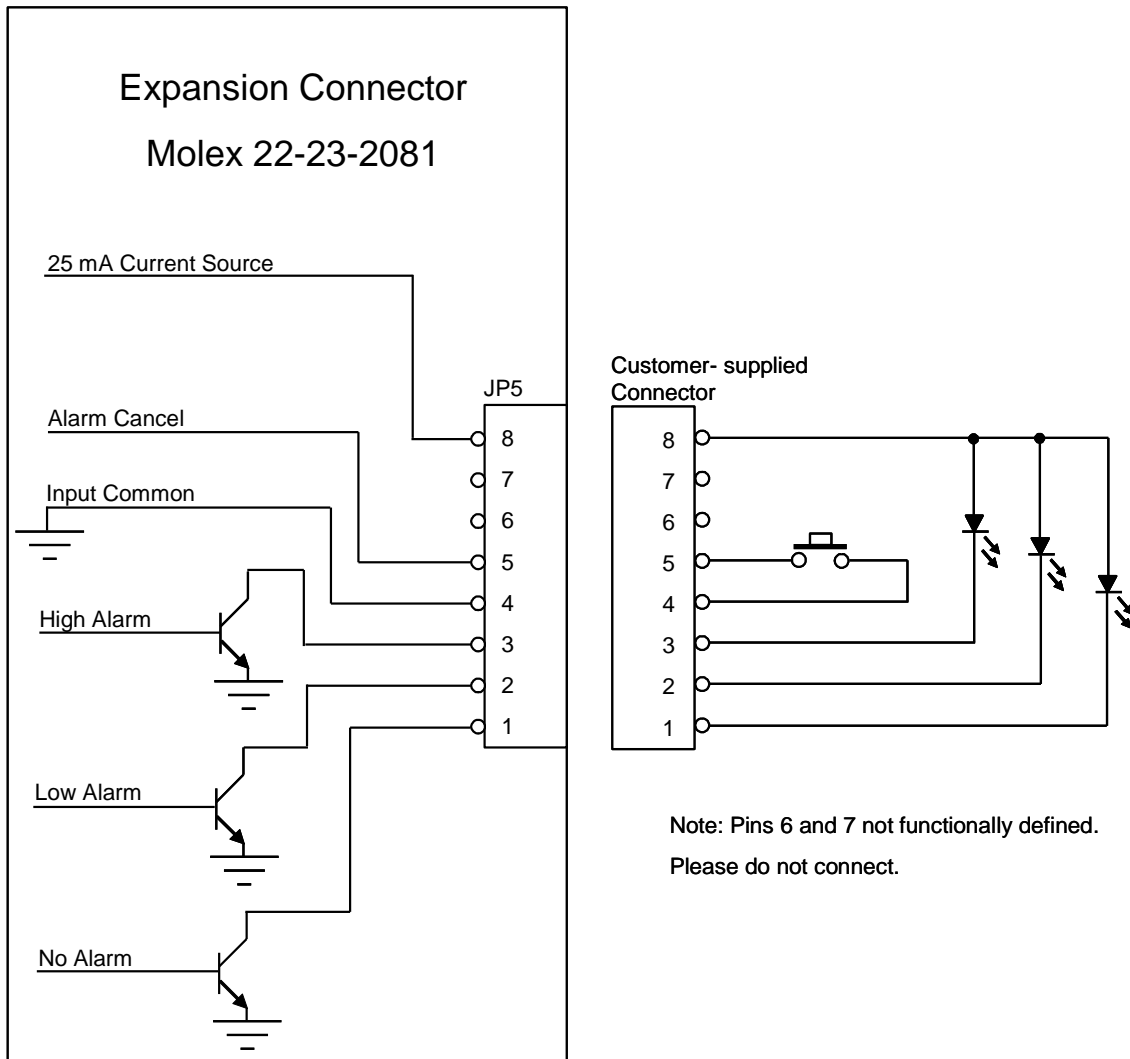

Mechanical Package Drawing

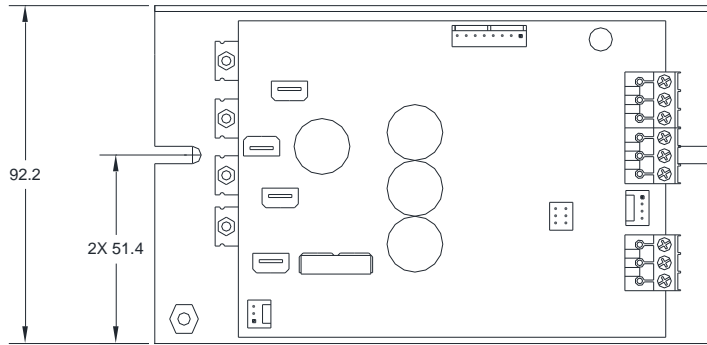

DIMENSIONS IN MILLIMETERS

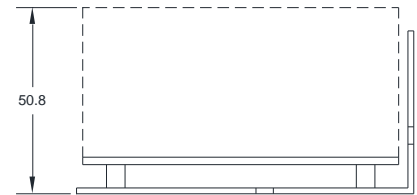
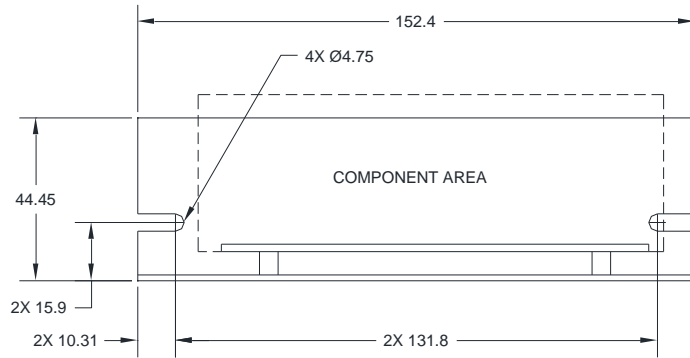

Block Diagram

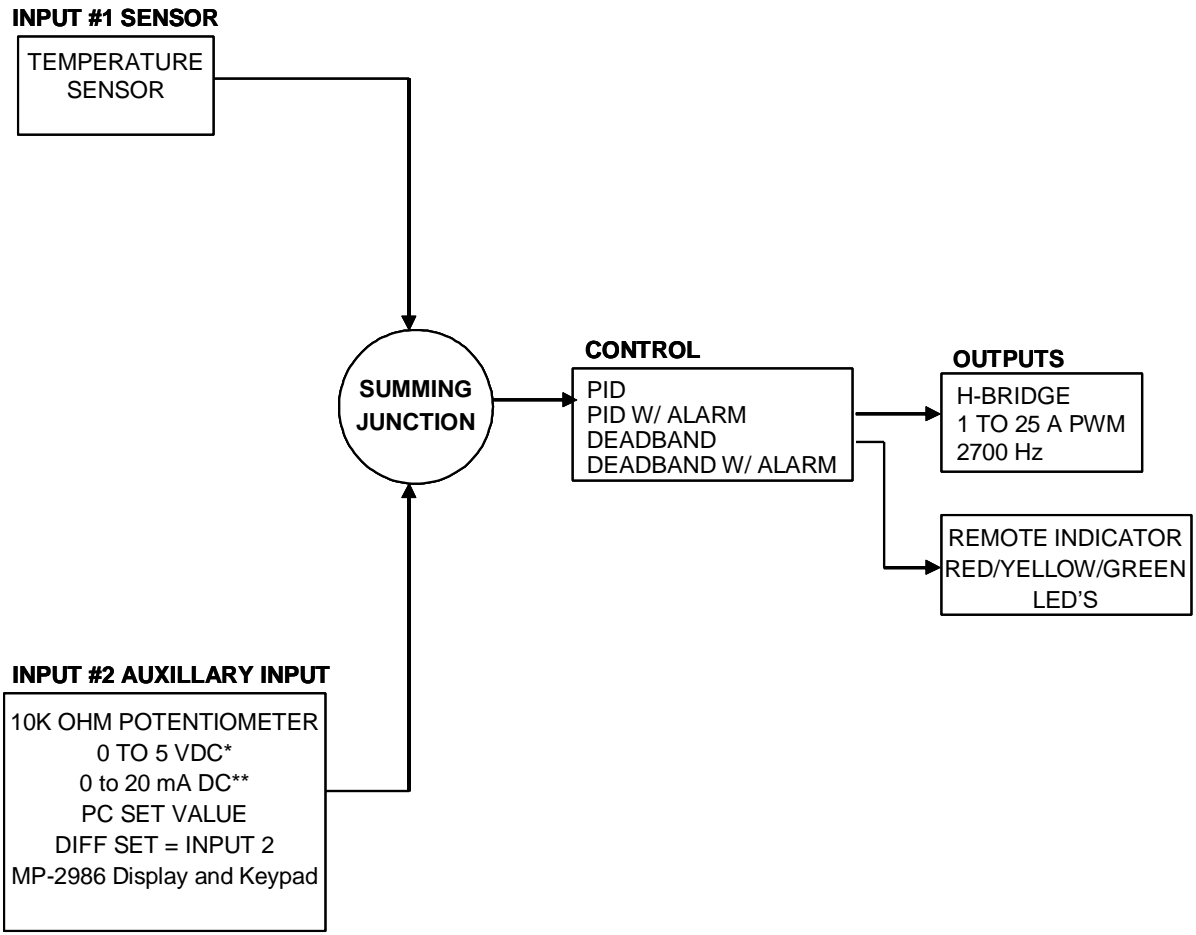

*CONTROLLER INPUT IMPEDANCE 6.5K OHMS

**REQUIRES ADDITION OF EXTERNAL RESISTOR

RS485 Communications Connections

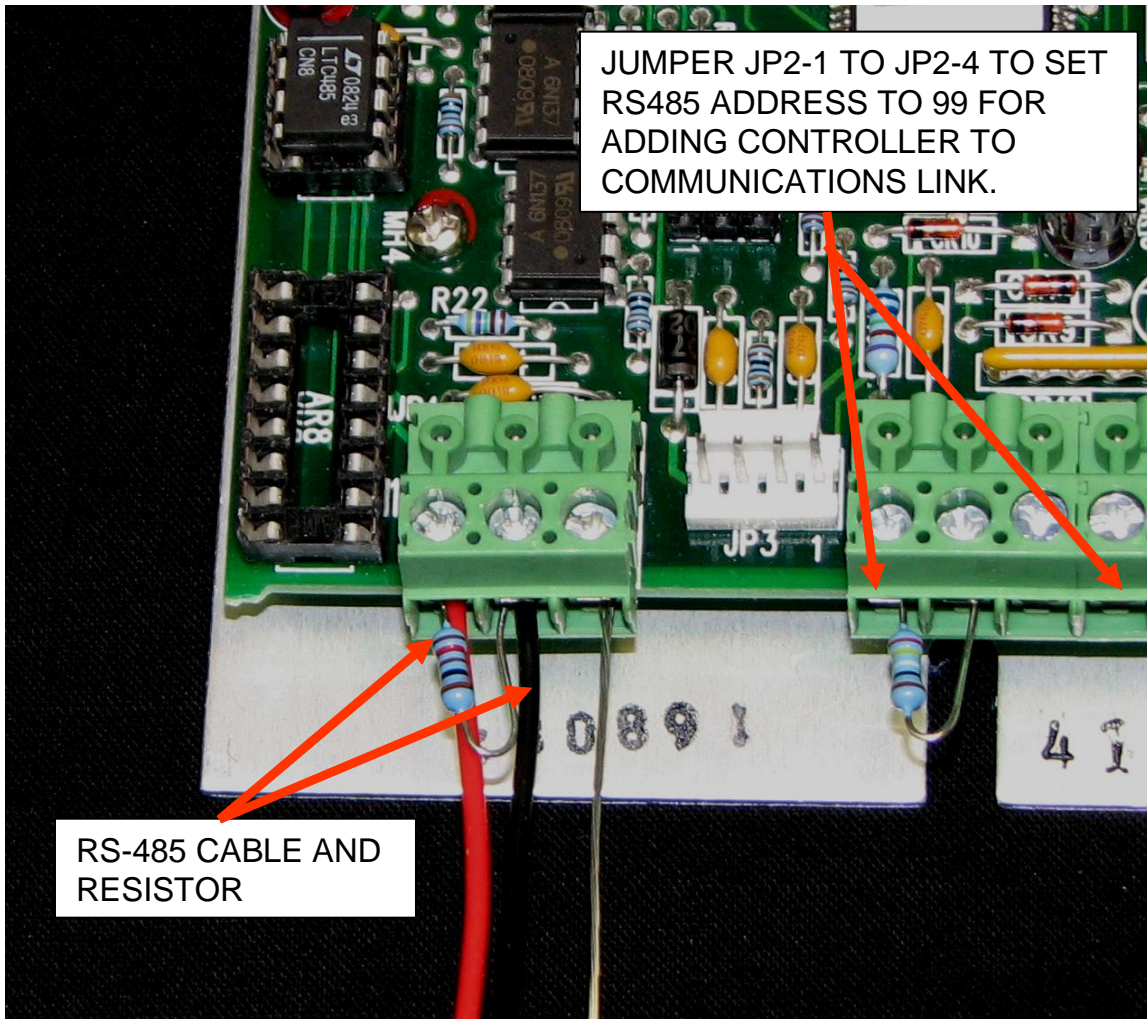

RS485 Connection Table

Computer/RS485 Adapter	Communication Path	Controller Function	Controller Connection
Data + (B), (TxD)	→	Data - (A), (RxD)	JP4-1
Data - (A), (RxD)	←	Data + (B), (TxD)	JP4-2
reference	---	reference	JP4-3

Appendix A Troubleshooting Controller

CONTROLLER NOT PROVIDING THE EXPECTED OUTPUT POWER:

COMMUNICATION

PROBLEM: A communication problem is not allowing software to turn the output ON, or some other parameter is not set properly due to communication problem. See Appendix B, Troubleshooting Communications.

HEAT SIDE MULTIPLIER: See Section 2.7.2 for reference. If this is set to 0.00, the controller will not provide any output power when the controller goes into the heating mode. Set this value to something greater than zero to restore the controller's capability of heating.

COOL SIDE MULTIPLIER: See Section 2.7.3 for reference. If this is set to 0.00, the controller will not provide any output power when the controller is in the cooling mode. Set this value to something greater than zero to restore the controller's capability of cooling.

LOW VOLTAGE: See Section 2.6.1 for reference. Verify the controller is receiving at least 12 V from the power supply. The controller will shut off output power to protect the MOSFETs from damage if the input voltage drops below 11.2 V.

OVER CURRENT: See Section 2.7.4, 2.7.5, and 2.6.1. Verify that the over-current level is set to an appropriate amount that is at least greater than the expected current draw of the thermoelectric device used with the controller. Check that a sufficient number of over-current restart attempts has been set.

OUTPUT ON/OFF: See Section 2.7. Verify that the controller has been set to turn on output power. You should also verify that the power supply is capable of providing the expected amount of current for the thermoelectric device at the voltage supplied by the power supply. If the power supply cannot provide sufficient current, it may be in an over-current condition.

ALARM: See Sections 2.6-2.6.6. Verify that there are no alarm conditions and that the temperatures which trigger an alarm condition are set correctly. If an alarm has occurred, correct the conditions causing the alarm. Then click the SEND LATCH CLEAR button.

SYSTEM TEMPERATURE INCREASES WHEN COOLING EXPECTED:

INSUFFICIENT

HEAT SINK: The thermoelectric (Peltier) elements do not have a sufficient heat sink, and input power heats entire system. In such a case, there is usually some initial reduction in temperature when power to the thermoelectric device is first turned on, but this is soon followed by a gradual heating of the system.

OUTPUT POLARITY

REVERSED: Review section 2.7.1 and wire attachments from controller to cooler. Ensure the wire polarity is correct per schematic, and ensure proper control mode is selected. Ensure wire attachment (polarity) to the cooling device is correct. For thermoelectric (Peltier) modules, review the "Thermoelectric Module Mounting (TEM) Mounting Procedure", available from www.tetech.com, and verify physical orientation of the cold side module within the system. For TE Technology standard cooling assemblies, verify wires are attached to proper positions on terminal strip (see section 3.1).

SYSTEM TEMPERATURE DOES NOT RESPOND AS EXPECTED:

CONTROL TYPE

IMPROPERLY SET: Set CONTROL TYPE to PID control if you want the temperature controller to adjust the output power based on the actual temperature and the set temperature. Set CONTROL TYPE to COMPUTER CONTROL if you want to use an external computer to adjust the power output manually. See Section 2.5.1.

IMPROPER

SENSOR TYPE: Only NTC thermistors of proper type can be utilized. Verify an NTC thermistor is being used and its Resistance-versus-Temperature (R-T) curve is one that is supported by the controller. Verify the proper SENSOR TYPE has been selected, see Section 2.3.

DIGITAL DISPLAY (MP-2986) DOES NOT RESPOND AS EXPECTED:

“Serr” DISPLAYED: EXTERNAL DISPLAY ENABLE has not been turned on. See Section 2.4.2

DISPLAY DOES NOT
ALTER SET

TEMPERATURE: USE SET VALUE OF DISPLAY must be selected. See Section 2.2.1. The HIGH EXTERNAL SET RANGE and LOW EXTERNAL SET RANGE (see Section 2.2.4) need to also be set to define the high and low limits that the temperature can be set to.

APPENDIX B: Troubleshooting Communications

Troubleshooting RS485

When you initialize, an error message may show up if there is any additional problem. The following table offers possible solutions corresponding to a particular error:

Error Message	Possible Cause	Solution
Zero Controllers Found	No power to TC-36-25 RS485 unit	Apply power to TC-36-25 RS485, review customer-hookup drawing for proper hookup
Zero Controllers Found	RS485 SEARCH TO Address is too low	Set to a higher value
Zero Controllers Found	Wrong COM Port selected	Check computer hardware setting and set to the correct Comm Port
VISA Read Error	Framing Error during transfer of data	Click Continue to resume program operation
Comm. Port Not Responding	Incorrect wiring of Comm Port to the converter or computer	Check for correct wiring of the converter to the computer, review converter specifications & computer for proper hookup*
Comm. Port Not Responding	Converter is not connected to TC-36-25 RS485	Check for correct connection of the converter to TC-36-25 RS485, review converter specifications & TC-36-25 RS485 customer drawing for proper hookup
Comm. Port Not Responding	Incorrect wiring of the converter to TC-36-25 RS485	Check for correct wiring of the converter to TC-36-25 RS485, review converter specifications & TC-36-25 RS485 customer drawing for proper hookup
Comm. Port Not Responding	RS485 Adaptor incorrectly or not installed	Reinstall or install RS485 Adaptor

*See the “*RS485 Communications Connections*” above for the correct connections. The DATA + from the computer connects to the DATA – of the controller; likewise the DATA – from the controller connects to the DATA + of the controller.

The controller will not communicate with the computer if the port settings are incorrect. The port settings for the RS485 controller are:

- Baud Rate – 115200
- Data Bits – 8
- Parity – None
- Stop Bits – 1
- Flow Control – None

APPENDIX C: Serial Communications

I. Definitions:

Note: where needed, the base of a number is indicated by its subscript. So, 20_{10} is the number 20 in decimal (base 10) format, and it converts to 14_{16} in hexadecimal (base 16) format.

Use lowercase ASCII characters.

(stx) Start of text character (*) or $2a_{16}$.

(etx) End of text character (carriage return) or $0d_{16}$.

(ack) Acknowledge character (^) or $5e_{16}$.

AA Address characters are ASCII characters ranging from 0 through 9 or a through f.

CC Command characters are ASCII characters from 0 through 9 or a through f.

DDDDDDDD This is the ASCII representation of the hexadecimal return or send value. Negative numbers are represented by the hex 2's complement of the number (32-bit word size):

$1_{10} = 00000001_{16}$

$-1_{10} = \text{ffffff}f_{16}$

SS The 8-bit (modulo 256) hexadecimal checksum of characters sent to/from the controlling computer. This is represented as 2 ASCII characters. The checksum calculation excludes the characters (stx), SS, and (etx). *The TC-36-25 RS485 sums (in an 8-bit register) the hexadecimal values of the ASCII characters sent to/from the controlling computer. Any overflow is truncated, leaving the 8-bit (modulo 256) checksum. When the controller is receiving data, this controller calculates the checksum and compares it to the checksum sent by the controlling computer. The TC-36-25 RS485 will respond as shown below depending on whether or not the checksums match. When the controlling computer is receiving data the checksum sent by the controller can be used to make sure the data has not been received with an error. Remember, when finding the ASCII value for a hexadecimal number (a, b, c, d, e, and f) be sure to reference lower case letters.*

To write a command to the controller, the controlling computer must send the following ASCII characters:

(stx)AACDDDDDDSS(etx)

If the temperature controller receives the command and the checksum is correct, the temperature controller will respond by sending back the "send value" and the checksum of those eight ASCII characters:

(stx)DDDDDDSS(ack)

To query a controller, there is no send value so the controlling computer only needs to send the following ASCII characters with the "D"s filled with zeros:

(stx)AACC000000SS(etx)

If the temperature controller receives the query and the checksum is correct, the temperature controller will respond by sending back a "return value" and the checksum of those eight ASCII characters:

(stx)DDDDDDSS(ack)

If the checksum for a command or query is not correct the temperature controller will respond with eight upper case X's and then c0, which is the checksum of these eight X's:

(stx)XXXXXXXXc0(ack)

II. Examples:

A) Set the controller to control via a computer programmable set point.

1. The controller address, AA, is in this example 62_{16} . (The default address of the controller is 98_{10} , but this must first be converted to hexadecimal for the proper send value.)
2. The write command, CC, for "SET TYPE DEFINE" is 29.
3. A data value of "0" selects a computer communicated set value, so the eight-character send value DDDDDDDD is 00000000.
4. Compute the checksum (SS) by adding the hexadecimal ASCII values of the following characters: 6, 2, 2, 9, 0, 0, 0, 0, 0, 0, 0, and 0:

<u>ASCII Character:</u>	<u>Hexadecimal Value:</u>
6	36
2	32
2	32
9	39
0	30
0	30
0	30
0	30
0	30
0	30
0	30
0	30
0	30
<u>0</u>	<u>30</u>
Sum	0253₁₆

The 8-bit checksum is the 8 least significant binary bits of the sum, represented as 53 in hexadecimal.

5. Combining all of these characters into one string we send: (stx)62290000000053(etx).
6. If the temperature controller receives the command and the checksum is correct, it will send back: (stx)0000000080(ack). If the checksum is not correct the temperature controller will send back: (stx)XXXXXXXXc0(ack).

B) Send the set temperature of 10.00 to the controller.

1. The controller address, AA, is in this example 62_{16} .
2. The control command, CC, for "FIXED DESIRED CONTROL SETTING" is 1c.
3. Multiply the desired set-point temperature by 100_{10} ($10.00 \times 100 = 1000$).
4. Convert 1000_{10} to hexadecimal ($3e8_{16}$) and add on leading zeros to make the eight-character send value DDDDDDDD (000003e8).
5. Compute the checksum (SS) by adding the ASCII values of the following characters: 6, 2, 1, c, 0, 0, 0, 0, 0, 3, e, and 8:

<u>ASCII Character:</u>	<u>Hexadecimal Value:</u>
6	36
2	32
1	31
c	63
0	30
0	30
0	30
0	30
0	30
0	30
0	30
3	33
e	65
<u>8</u>	<u>38</u>
Sum	02bc₁₆

The 8-bit checksum is the 8 least significant binary bits of the sum, represented as bc in hexadecimal.

6. Combining all of these characters in one string we send: (stx)621c000003e8bc(etx).

- If the temperature controller receives the command and the checksum is correct, it will send back: (stx)000003e8c0(ack). If the checksum is not correct the temperature controller will send back: (stx)XXXXXXXXc0(ack).

C) Send the set temperature of -1.50 °C.

- The controller address, AA, is in this example 62₁₆.
- The control command, CC, for "FIXED DESIRED CONTROL SETTING" is 1c.
- Multiply the desired set-point temperature by 100₁₀ (-1.50 x 100 = -150).
- Convert -150₁₀ to hexadecimal by taking the two's complement of the number. (This can be easily done by using the formula $2^n - N$, where n is the word-bit size and N is the absolute value of the number being converted.) Hence, you have $2^{32} - 150 = 429496714610$. This value then converts to fffff6a₁₆.
- Compute the checksum (SS) by adding the hexadecimal ASCII values of the following characters: 6, 2, 1, c, f, f, f, f, f, f, 6, and a:

<u>ASCII Character:</u>	<u>Hexadecimal Value:</u>
6	36
2	32
1	31
c	63
f	66
f	66
f	66
f	66
f	66
f	66
f	66
6	36
<u>a</u>	<u>61</u>
Sum	3f7₁₆

The 8-bit checksum is the 8 least significant binary bits of the sum, represented as f7 in hexadecimal.

- Combining all of these characters in one string we send: (stx)621cffff6af7(etx).
- If the temperature controller receives the command and the checksum is correct, it will send back: (stx)ffff6afb(ack). If the checksum is not correct the temperature controller will send back: (stx)XXXXXXXXc0(ack).

D) Read the actual temperature of the control thermistor (INPUT1) from the controller at address 62₁₆.

- Let us assume the actual temperature is 2.50 °C, and the working units have been defined as °C. This means that the controller will return a value in °C.
- The controller address, AA, is in this example 00.
- The control command, CC, for "INPUT1" is 01.
- There is no send value, so we can just calculate the checksum (SS) by adding the ASCII values of the following characters: 6, 2, 0, 1, 0, 0, 0, 0, 0, 0, 0:

<u>ASCII Character:</u>	<u>Hexadecimal Value:</u>
6	36
2	32
0	30
1	31
0	30
0	30
0	30
0	30
0	30
0	30
0	30
0	30
0	30
<u>0</u>	<u>30</u>
Sum	0249₁₆

The 8-bit checksum is the 8 least significant binary bits of the sum, represented as 49 in hex.

- Combining all of these characters in one string we send: (stx)6201000000049(etx).

6. If the temperature controller receives the command and the checksum is correct, it will send back: (stx)000000fae7(ack). The e7 at the end of the string is the checksum of "000000fa". The value 000000fa₁₆ converts to 250₁₀. This number must then be divided by 100₁₀, so the value would be interpreted as 2.50 °C. As in the other examples, if the checksum from the query were not correct the temperature controller would send back: (stx)XXXXXXXXc0(ack).

III. Communications Parameters (JP4 connector on controller board)

RS485
Baud Rate - 115200
Data Bits - 8
Parity - None
Stop Bits - 1
Flow Control - None

IV. Commands

1. INPUT1 (reads the temperature of the primary thermistor)

Write Command: NA

Read Command: 01

Interpret: Convert the hexadecimal "return value" to decimal and divide by 100₁₀ to interpret as the temperature in °F/°C.

Example:

Suppose the temperature is 10.00 °F (sensor type = 1), and the address is 62₁₆.

Send: *6201000000049^

Receive: *000003e8c0^

Convert 000003e8₁₆ to decimal = 1000₁₀

Divide by 100 = (10.00 °F)

2. DESIRED CONTROL VALUE (set value)

Write Command: NA

Read Command: 03

Interpret: This command returns the set value determined by Input2 or as a fixed value set by communications. Convert the hexadecimal "return value" to decimal and divide by 100₁₀ to interpret.

3. POWER OUTPUT

Write Command: NA

Read Command: 02 or 04

Interpret: -511₁₀ represents -100% output.

0 returned is 0% output.

511₁₀ represents 100% output.

4. ALARM STATUS

Write Command: NA

Read Command: 05

Interpret: 0 returned means no alarms.
Bit 0 = 1 means HIGH ALARM.
Bit 1 = 1 means LOW ALARM.
Bit 2 = 1 means COMPUTER CONTROLLED ALARM.
Bit 3 = 1 means OVER CURRENT DETECTED.
Bit 4 = 1 means OPEN INPUT1.
Bit 5 = 1 means OPEN INPUT2.
Bit 6 = 1 means DRIVER LOW INPUT VOLTAGE.

Example:

Suppose there are two alarm conditions: HIGH ALARM and OVER CURRENT DETECTED.

Send: *620500000004d^

Receive: *000000989^

Convert 0000009₁₆ to binary: 0001001₂ (bit 3 and bit 0 are set)

5. INPUT 2

Write Command: NA

Read Command: 06 hex

Interpret: When a secondary thermistor temperature sensor is used, the temperature it is sensing can be read. Convert the hexadecimal "return value" to decimal and divide by 100₁₀ to interpret as °F/°C.

6. OUTPUT CURRENT COUNTS

Write Command: NA

Read Command: 07

Interpret: Output current detection in A/D counts.

7. ALARM TYPE

Write Command: 28

Read Command: 41

Interpret: 0 sent or returned means no alarms.
1 sent or returned means Tracking Alarm Mode.
2 sent or returned means Fixed Alarm Mode.
3 sent or returned means Computer Controlled Alarm Mode (see write command ALARM LATCH ENABLE).

8. SET TYPE DEFINE (the desired control temperature or "set temp" input definition)

Write Command: 29

Read Command: 42

Interpret: This function tells the controller how the set-point will be communicated.
0 sent or returned means computer communicated set value.
1 sent or returned means Potentiometer Input.
2 sent or returned means 0 to 5 V Input.
3 sent or returned means 0 to 20 mA Input.
4 sent or returned means "Differential set": Desired Control Value = Temp2 + Computer Set.
5 sent or returned means set value is from optional MP-2986 Display and Keypad accessory.

The range of values is settable via the commands HIGH EXTERNAL SET RANGE and LOW EXTERNAL SET RANGE.

9. SENSOR TYPE

Write Command: 2a
Read Command: 43
Interpret: 0: TS141 5K
1: TS67 OR TS136 15K
2: TS91 10K
3: TS165 230K
4: TS104 50K
5: YSI H TP53 10K

10. CONTROL TYPE

Write Command: 2b
Read Command: 44
Interpret: 0 is deadband control.
1 is PID control.
2 is computer control.

11. CONTROL OUTPUT POLARITY

Write Command: 2c
Read Command: 45
Interpret: 0 is HEAT WP1+ and WP2-.
1 is HEAT WP2+ and WP1-.

12. OUTPUT ON/OFF

Write Command: 2d
Read Command: 46
Interpret: 0 is off.
1 is on.

13. OUTPUT SHUTDOWN IF ALARM

Write Command: 2e
Read Command: 47
Interpret: 0 is no shutdown upon alarm.
1 is to shutdown main output drive upon alarm.

14. FIXED DESIRED CONTROL SETTING

Write Command: 1c
Read Command: 50
Interpret: When writing, multiply the desired control temperature by 100_{10} and convert to hexadecimal. This becomes the "send value." When reading, convert the "return value" to decimal and divide by 100_{10} to convert to $^{\circ}\text{F}/^{\circ}\text{C}$.

When CONTROL TYPE is set to "computer control", the output power sent to the cooler can be set anywhere from -511_{10} to $+511_{10}$, corresponding to -100% to +100% output power. Remember to convert to hexadecimal before sending.

15. PROPORTIONAL BANDWIDTH

Write Command: 1d
Read Command: 51
Interpret: Fixed-point temperature bandwidth distributed around the control setting in $^{\circ}\text{F}/^{\circ}\text{C}$. A value of $5^{\circ}\text{F}/^{\circ}\text{C}$ for bandwidth and control setting of $25^{\circ}\text{F}/^{\circ}\text{C}$ would place the proportional band from $20^{\circ}\text{F}/^{\circ}\text{C}$ to $30^{\circ}\text{F}/^{\circ}\text{C}$; that is, 5° above and 5° below set point.

When writing, first multiply the desired bandwidth setting by 100_{10} and convert to hexadecimal for the "send value." When reading, convert the "return value" to decimal and divide by 100_{10} to convert to $^{\circ}\text{F}/^{\circ}\text{C}$.

16. INTEGRAL GAIN

Write Command: 1e

Read Command: 52

Interpret: Fixed-point gain in repeats/min.
Multiply desired integral gain by 100_{10} and convert to hexadecimal for the "send value." When reading, convert the "return value" to decimal and divide by 100_{10} to interpret.

17. DERIVATIVE GAIN

Write Command: 1f

Read Command: 53

Interpret: Fixed-point gain in minutes.
Multiply desired derivative gain by 100_{10} and convert to hexadecimal for the "send value." When reading, convert the "return value" to decimal and divide by 100_{10} to interpret.

18. LOW EXTERNAL SET RANGE

Write Command: 20

Read Command: 54

Interpret: Value mapped to zero voltage of Input2. Only integer values are allowed. Remember to convert to hexadecimal before sending.

19. HIGH EXTERNAL SET RANGE

Write Command: 21

Read Command: 55

Interpret: Value mapped to 5 volt or maximum voltage of Input2. Only integer values are allowed. Remember to convert to hexadecimal before sending.

20. ALARM DEADBAND

Write Command: 22

Read Command: 56

Interpret: Temperature Input1 must move to toggle alarm output. When writing, first multiply the desired deadband setting by 100_{10} and convert to hexadecimal for the "send value." When reading, convert the "return value" to decimal and divide by 100_{10} to convert to °F/°C.

21. HIGH ALARM SETTING

Write Command: 23

Read Command: 57

Interpret: Temperature reference to compare against Input1 for high alarm output. When writing, first multiply the desired setting by 100_{10} and convert to hexadecimal for the "send value." When reading, convert the "return value" to decimal and divide by 100_{10} to convert to °F/°C.

22. LOW ALARM SETTING

Write Command: 24

Read Command: 58

Interpret: Temperature reference to compare against Input1 for low alarm output. When writing, first multiply the desired setting by 100_{10} and convert to hexadecimal for the "send value." When reading, convert the "return value" to decimal and divide by 100_{10} to convert to °F/°C.

23. CONTROL DEADBAND SETTING

Write Command: 25

Read Command: 59

Interpret: Temperature or count span Input1 must move to toggle control output. When writing, first multiply the desired setting by 100_{10} and convert to hexadecimal for the "send value." When reading, convert the "return value" to decimal and divide by 100_{10} to convert to °F/°C.

24. INPUT1 OFFSET

Write Command: 26

Read Command: 5a

Interpret: Value to offset Input1 by in order to calibrate external sensor if desired. When writing, first multiply the desired setting by 100_{10} and convert to hexadecimal for the "send value." When reading, convert the "return value" to decimal and divide by 100_{10} to convert to °F/°C.

25. INPUT2 OFFSET

Write Command: 27

Read Command: 5b

Interpret: Value to offset Input2 by in order to calibrate external sensor if desired. When writing, first multiply the desired setting by 100_{10} and convert to hexadecimal for the "send value." When reading, convert the "return value" to decimal and divide by 100_{10} to convert to °F/°C.

26. HEAT MULTIPLIER

Write Command: 0c

Read Command: 5c

Interpret: This multiplies the heater percentage of power to offset its effectiveness. When writing, first multiply the desired setting by 100_{10} and convert to hexadecimal for the "send value." When reading, convert the "return value" to decimal and divide by 100_{10} to interpret.

27. COOL MULTIPLIER

Write Command: 0d

Read Command: 5d

Interpret: This multiplies the cooling percentage of power to offset its effectiveness. When writing, first multiply the desired setting by 100_{10} and convert to hexadecimal for the "send value." When reading, convert the "return value" to decimal and divide by 100_{10} to interpret.

28. OVER CURRENT COUNT COMPARE VALUE

Write Command: 0e

Read Command: 5e

Interpret: This is the count compare value which determines an over-current condition. Current is approximately 2.5 per count. Only integer values are allowed. Remember to convert to hexadecimal before sending.

29. ALARM LATCH ENABLE

Write Command: 2f

Read Command: 48

Interpret: 1 is latching enabled.
0 is latching disabled.
If ALARM TYPE is equal to 3 then
1 is Computer Alarm On.
0 is Computer Alarm Off.

30. COMMUNICATION ADDRESS

Write Command: 30

Read Command: 49

Interpret: Range of value 01₁₆ to ff₁₆
This is the AA value in the communication string for RS485 version. Address 00₁₆ and 63₁₆ (corresponding to address 99₁₀) are reserved; do not assign either of these addresses to a controller.

31. ALARM LATCH RESET

Write Command: 33

Read Command: NA

Interpret: Send this command to reset the alarm latches.

32. CHOOSE SENSOR FOR ALARM FUNCTION

Write Command: 31

Read Command: 4a

Interpret: 0 is for the Control Sensor Input.
1 is for the Input2 Secondary Input.

33. CHOOSE °C or °F TEMPERATURE WORKING UNITS

Write Command: 32

Read Command: 4b

Interpret: 0 is °F
1 is °C

34. EEPROM WRITE ENABLE

Write Command: 34

Read Command: 4c

Interpret: 0 is disable EEPROM writes
1 is enable EEPROM writes

Function Description: Upon a power-up or reset condition, the controller performs an initialization of all command variables that have write commands by transferring the last values stored in non-volatile memory (EEPROM) to appropriately referenced static RAM locations. This action is performed so that the controller can run faster (RAM is faster than ROM). When the "EEPROM WRITE ENABLE" is enabled, any changes in the run-time values of the command variables are also stored in EEPROM as well in RAM and thus will be recalled upon a power-up or reset condition. When the "EEPROM WRITE ENABLE" is disabled, run-time values are stored only in RAM. This setting gives you the ability to change run-time values without changing your desired power-up settings. This will also alleviate a possible problem since the maximum number of writes to an EEPROM location is 1,000,000.

35. OVER CURRENT CONTINUOUS

Write Command: 35

Read Command: 4d

Interpret: 1 is continuous retry when over current detected.
0 allows the RESTART ATTEMPTS value to be used.

36. OVER CURRENT RESTART ATTEMPTS

Write Command: 0f

Read Command: 5f

Interpret: Range of value 0 to 30000₁₀

This is the amount of times the controller will attempt to restart the output after an over current condition is detected.

37. JP3 DISPLAY ENABLE

Write Command: 36

Read Command: 4e

Interpret: 1 display function enabled.
0 display function disabled.

V. ASCII Reference Table

Dec	Oct	Hex	Binary	Description
000	000	00	00000000	^@ ^` NULL NUL null c-@ c-`
001	001	01	00000001	^A ^a SOH GTL c-A c-a start-of-heading
002	002	02	00000010	^B ^b STX c-B c-b start-of-text
003	003	03	00000011	^C ^c ETX c-C c-c end-of-text
004	004	04	00000100	^D ^d EOT SDC end-of-transmission c-D c-d ..._._
005	005	05	00000101	^E ^e ENQ PPC c-E c-e enquiry
006	006	06	00000110	^F ^f ACK c-F c-f acknowledge
007	007	07	00000111	^G ^g BELL BEL bell c-G c-g \a
008	010	08	00001000	^H ^h BS GET backspace c-H c-h \b
009	011	09	00001001	^I ^i TAB TCT HT tab c-I c-i \t
010	012	0A	00001010	^J ^j LF lf linefeed c-J c-j \n
011	013	0B	00001011	^K ^k VT vertical-tab c-K c-k \v
012	014	0C	00001100	^L ^l FF ff formfeed page \f c-L c-l
013	015	0D	00001101	^M ^m CR cr carriage-return c-M c-m \r
014	016	0E	00001110	^N ^n SO c-N c-n shift-out
015	017	0F	00001111	^O ^o SI c-O c-o shift-in
016	020	10	00010000	^P ^p DLE c-P c-p data-link-escape
017	021	11	00010001	^Q ^q DC1 LLO go XON xon c-Q c-Q
018	022	12	00010010	^R ^r DC2 c-R c-r
019	023	13	00010011	^S ^s DC3 stop XOFF xoff c-S c-s
020	024	14	00010100	^T ^t DC4 DCL c-T c-t
021	025	15	00010101	^U ^u NAK PPU negative-acknowledge c-U c-u
022	026	16	00010110	^V ^v SYN c-V c-v synchronous-idle
023	027	17	00010111	^W ^w ETB end-of-transmission-block c-W c-w
024	030	18	00011000	^X ^x CAN SPE c-X c-x cancel
025	031	19	00011001	^Y ^y EM SPD c-Y c-y end-of-medium
026	032	1A	00011010	^Z ^z SUB suspend c-Z c-z substitute
027	033	1B	00011011	^[^{ ESC escape c-[c-{ m-
028	034	1C	00011100	^\ ^ FS field-separator c-\ c-
029	035	1D	00011101	^] ^} GS group-separator
030	036	1E	00011110	^^ ^~ RS record-separator c-^ c-~
031	037	1F	00011111	^_ ^DEL unit-separator US c-_ c-DEL
032	040	20	00100000	SPC space spc
033	041	21	00100001	! exclamation-point
034	042	22	00100010	" straight-double-quotation-mark
035	043	23	00100011	# number-sign
036	044	24	00100100	\$ @@ dollar-sign
037	045	25	00100101	% percent-sign
038	046	26	00100110	& ampersand
039	047	27	00100111	' apostrophe
040	050	28	00101000	(left-parenthesis
041	051	29	00101001) right-parenthesis
042	052	2A	00101010	* asterisk star
043	053	2B	00101011	+ addition-sign
044	054	2C	00101100	, comma
045	055	2D	00101101	- subtraction-sign minus hyphen negative dash
046	056	2E	00101110	. period dot decimal
047	057	2F	00101111	/ right-slash
048	060	30	00110000	0
049	061	31	00110001	1
050	062	32	00110010	2
051	063	33	00110011	3
052	064	34	00110100	4

053	065	35	00110101	5
054	066	36	00110110	6
055	067	37	00110111	7
056	070	38	00111000	8
057	071	39	00111001	9
058	072	3A	00111010	: colon
059	073	3B	00111011	; semicolon
060	074	3C	00111100	< less-than
061	075	3D	00111101	= equals
062	076	3E	00111110	> greater-than, right-chevron
063	077	3F	00111111	? question-mark, query
064	100	40	01000000	@ at-symbol, at-sign
065	101	41	01000001	A
066	102	42	01000010	B
067	103	43	01000011	C
068	104	44	01000100	D
069	105	45	01000101	E
070	106	46	01000110	F
071	107	47	01000111	G
072	110	48	01001000	H
073	111	49	01001001	I
074	112	4A	01001010	J
075	113	4B	01001011	K
076	114	4C	01001100	L
077	115	4D	01001101	M
078	116	4E	01001110	N
079	117	4F	01001111	O
080	120	50	01010000	P
081	121	51	01010001	Q
082	122	52	01010010	R
083	123	53	01010011	S
084	124	54	01010100	T
085	125	55	01010101	U
086	126	56	01010110	V
087	127	57	01010111	W
088	130	58	01011000	X
089	131	59	01011001	Y
090	132	5A	01011010	Z
091	133	5B	01011011	[left-bracket, open-square
092	134	5C	01011100	\ left-slash, backslash bash
093	135	5D	01011101] right-bracket, close-square
094	136	5E	01011110	^ hat, circumflex, caret, up-arrow
095	137	5F	01011111	_ UNT, underscore, underbar
096	140	60	01100000	` accent-grave, backprime, backquote
097	141	61	01100001	a
098	142	62	01100010	b
099	143	63	01100011	c
100	144	64	01100100	d
101	145	65	01100101	e
102	146	66	01100110	f
103	147	67	01100111	g
104	150	68	01101000	h
105	151	69	01101001	i
106	152	6A	01101010	j
107	153	6B	01101011	k

108	154	6C	01101100	l
109	155	6D	01101101	m
110	156	6E	01101110	n
111	157	6F	01101111	o
112	160	70	01110000	p
113	161	71	01110001	q
114	162	72	01110010	r
115	163	73	01110011	s
116	164	74	01110100	t
117	165	75	01110101	u
118	166	76	01110110	v
119	167	77	01110111	w
120	170	78	01111000	x
121	171	79	01111001	y
122	172	7A	01111010	z
123	173	7B	01111011	{ left-brace begin
124	174	7C	01111100	logical-or vertical-bar
125	175	7D	01111101	} right-brace end
126	176	7E	01111110	~ similar
127	177	7F	01111111	^? DEL rubout delete

APPENDIX D: Thermistors for TC-36-25 RS485

Note: all dimensions in millimeters; standard thermistors have TS-67 temperature-resistance curves. See www.tetech.com for further optional thermistor styles available.

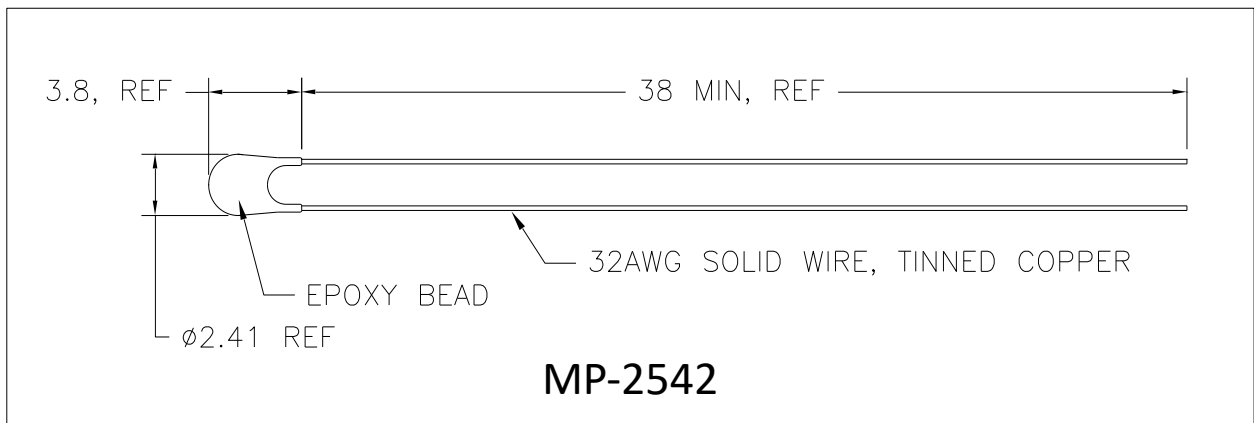
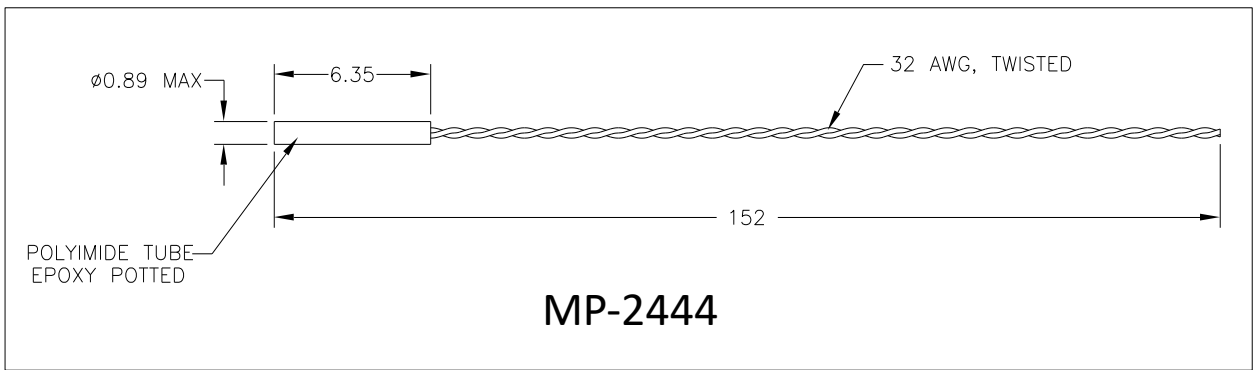
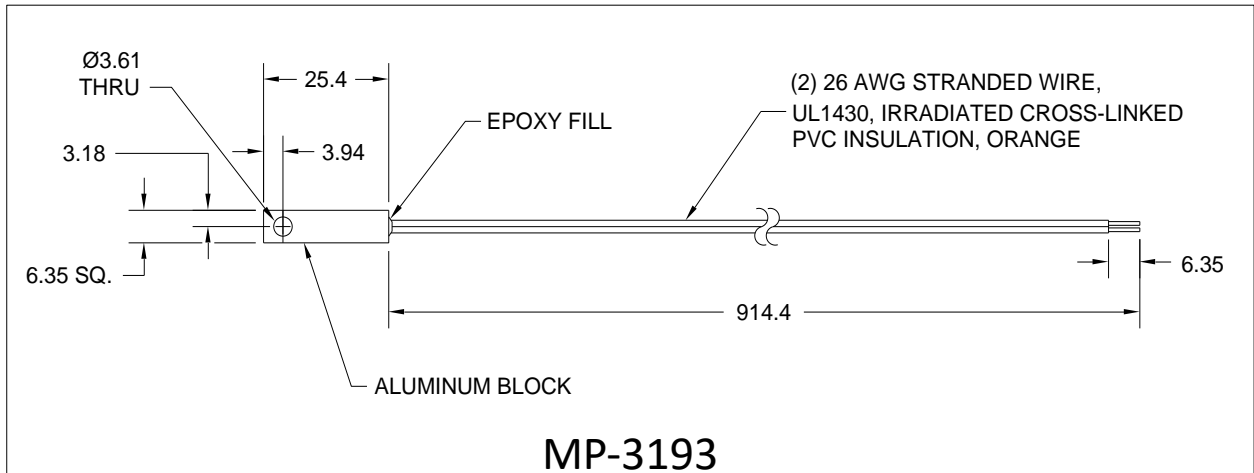

**TS-67 Temperature (°C) versus Resistance (ohms, Ω) Data
for MP-3193, MP-2444, MP-3189, MP-2996, and MP-2542 Thermistors**

-20	146735	1	46709	22	17136	43	7075	64	3227	85	1601
-19	138447	2	44397	23	16388	44	6801	65	3115	86	1551
-18	130677	3	42213	24	15676	45	6539	66	3008	87	1503
-17	123390	4	40150	25	15000	46	6289	67	2905	88	1457
-16	116554	5	38199	26	14356	47	6049	68	2806	89	1412
-15	110138	6	36354	27	13744	48	5820	69	2711	90	1369
-14	104113	7	34608	28	13161	49	5600	70	2620	91	1328
-13	98454	8	32957	29	12606	50	5391	71	2532	92	1288
-12	93137	9	31394	30	12078	51	5190	72	2448	93	1250
-11	88138	10	29914	31	11574	52	4997	73	2367	94	1212
-10	83438	11	28512	32	11095	53	4813	74	2288	95	1176
-9	79016	12	27183	33	10637	54	4637	75	2213	96	1142
-8	74855	13	25925	34	10202	55	4467	76	2141	97	1108
-7	70938	14	24731	35	9786	56	4305	77	2072	98	1076
-6	67249	15	23600	36	9389	57	4150	78	2005	99	1045
-5	63773	16	22526	37	9011	58	4001	79	1940	100	1014
-4	60498	17	21508	38	8650	59	3858	80	1878		
-3	57410	18	20541	39	8306	60	3721	81	1818		
-2	54498	19	19623	40	7976	61	3590	82	1761		
-1	51750	20	18751	41	7662	62	3464	83	1705		
0	49157	21	17923	42	7362	63	3343	84	1652		

Note: Tolerance is $\pm 650 \Omega$, corresponding to $\pm 1 \text{ }^\circ\text{C}$
over a $0 \text{ }^\circ\text{C}$ to $100 \text{ }^\circ\text{C}$ range.

**TS-141 Temperature (°C) versus Resistance (ohms, Ω) Data
for MP-3176**

-40	168300	-19	45830	2	14750	23	5460	44	2272	65	1041
-39	157500	-18	43270	3	14030	24	5225	45	2184	66	1006
-38	147500	-17	40860	4	13340	25	5000	46	2101	67	971
-37	138200	-16	38610	5	12700	26	4787	47	2021	68	938
-36	129500	-15	36490	6	12090	27	4583	48	1944	69	906.5
-35	121400	-14	34500	7	11510	28	4389	49	1871	70	875.5
-34	113900	-13	32630	8	10960	29	4204	50	1801		
-33	106900	-12	30880	9	10440	30	4029	51	1734		
-32	100300	-11	29230	10	9950	31	3861	52	1670		
-31	94200	-10	27670	11	9485	32	3702	53	1608		
-30	88500	-9	26210	12	9045	33	3549	54	1549		
-29	83200	-8	24830	13	8630	34	3404	55	1493		
-28	78250	-7	23540	14	8230	35	3266	56	1439		
-27	73600	-6	22320	15	7855	36	3134	57	1387		
-26	69250	-5	21170	16	7500	37	3008	58	1337		
-25	65200	-4	20080	17	7160	38	2888	59	1290		
-24	61450	-3	19060	18	6840	39	2773	60	1244		
-23	57900	-2	18100	19	6535	40	2663	61	1200		
-22	54550	-1	17190	20	6245	41	2559	62	1158		
-21	51450	0	16330	21	5970	42	2459	63	1117		
-20	48560	1	15520	22	5710	43	2363	64	1079		

TS-91 Temperature (°C) versus Resistance (ohms, Ω) Data

-20	97120	1	31040	23	10920	44	4544	65	2082
-19	91660	2	29500	24	10450	45	4368	66	2012
-18	86540	3	28060	25	10000	46	4202	67	1942
-17	81720	4	26680	26	9574	47	4042	68	1876
-16	77220	5	25400	27	9166	48	3888	69	1813
-15	72980	6	24180	28	8778	49	3742	70	1751
-14	69000	7	23020	29	8408	50	3602	71	1693
-13	65260	8	21920	30	8058	51	3468	72	1637
-12	61760	9	20880	31	7722	52	3340	73	1582
-11	58460	10	19900	32	7404	53	3216	74	1530
-10	55340	11	18970	33	7098	54	3098	75	1480
-9	52420	12	18090	34	6808	55	2986	76	1432
-8	49660	13	17260	35	6532	56	2878	77	1385
-7	47080	14	16460	36	6268	57	2774	78	1341
-6	44640	15	15710	37	6016	58	2674	79	1298
-5	42340	16	15000	38	5776	59	2580	80	1256
-4	40160	17	14320	39	5546	60	2488	81	1216
-3	38120	18	13680	40	5326	61	2400	82	1178
-2	36200	19	13070	41	5118	62	2316	83	1141
-1	34380	20	12490	42	4918	63	2234	84	1105
0	32660	21	11940	43	4726	64	2158	85	1071

TS-165 Temperature (°C) versus Resistance (ohms, Ω) Data

25	231438.2	71	35099.7	117	7792.1	163	2289.3	209	830.8
26	221032.6	72	33847.4	118	7567	164	2234.8	210	814.3
27	211147.1	73	32645.5	119	7349.4	165	2181.9	211	798.1
28	201753.2	74	31491.9	120	7139	166	2130.4	212	782.4
29	192824.2	75	30384.2	121	6935.4	167	2080.3	213	767
30	184334.8	76	29320.7	122	6738.6	168	2031.6	214	752
31	176261.5	77	28299.2	123	6548.2	169	1984.3	215	737.3
32	168581.8	78	27318.1	124	6363.9	170	1938.2	216	723
33	161274.8	79	26375.3	125	6185.6	171	1893.4	217	709
34	154320.7	80	25469.4	126	6013.1	172	1849.8	218	695.3
35	147700.8	81	24598.7	127	5846.1	173	1807.3	219	681.9
36	141397.6	82	23761.8	128	5684.4	174	1766	220	668.9
37	135394.3	83	22987.1	129	5527.9	175	1725.8	221	656.1
38	129675.4	84	22183.3	130	5376.3	176	1686.7	222	643.6
39	124226.1	85	21439.1	131	5229.6	177	1648.6	223	631.4
40	119032.5	86	20723.2	132	5087.4	178	1611.5	224	619.5
41	114081.4	87	20034.4	133	4949.7	179	1575.4	225	607.9
42	109360.3	88	19371.6	134	4816.3	180	1540.3	226	596.5
43	104857.6	89	18733.7	135	4687.1	181	1506.1	227	585.3
44	100562.2	90	18119.7	136	4561.8	182	1472.7	228	574.4
45	96463.6	91	17528.5	137	4440.4	183	1440.2	229	563.8
46	92551.8	92	16959.3	138	4322.8	184	1408.6	230	553.4
47	88817.6	93	16411.1	139	4208.7	185	1377.8	231	543.2
48	85252	94	15883	140	4098.7	186	1347.8	232	533.2
49	81846.8	95	15374.3	141	3991	187	1318.5	233	523.5
50	78593.9	96	14884.1	142	3887	188	1290	234	514
51	75485.9	97	14411.7	143	3786.2	189	1262.2	235	504.7
52	72515.7	98	13956.4	144	3688.3	190	1235.1	236	495.5
53	69676.6	99	13517.5	145	3593.5	191	1208.7	237	486.6
54	66962.1	100	13094.3	146	3501.4	192	1183	238	477.9
55	64366.4	101	12686.2	147	3412.1	193	1157.9	239	469.3
56	61883.6	102	12292.7	148	3325.4	194	1133.4	240	461
57	59508.3	103	11913	149	3241.3	195	1109.6	241	452.8
58	57235.5	104	11546.8	150	3159.6	196	1086.3	242	444.8
59	55060.2	105	11193.4	151	3080.3	197	1063.6	243	437
60	52977.8	106	10852.3	152	3003.4	198	1041.5	244	429.3
61	50984.1	107	10523.1	153	2928.6	199	1019.9	245	421.8
62	49074.7	108	10205.4	154	2856.1	200	998.8	246	414.4
63	47245.8	109	9898.6	155	2785.6	201	978.3	247	407.2
64	45493.6	110	9602.3	156	2717.1	202	958.2	248	400.2
65	43814.6	111	9316.3	157	2650.6	203	938.7	249	393.5
66	42205.4	112	9039.9	158	2586	204	919.6	250	386.5
67	40662.8	113	8773	159	2523.2	205	901		
68	39183.7	114	8515	160	2462.2	206	882.8		
69	37765.4	115	8265.8	161	2402.9	207	865		
70	36404.9	116	8024.9	162	2345.3	208	847.7		

**TS-104 Temperature (°C) versus Resistance (ohms, Ω) Data
for MP-3022**

0	163300	26	47870	52	16700	78	6705	104	3025	130	1503
1	155200	27	45830	53	16080	79	6490	105	2940	131	1465
2	147500	28	43890	54	15490	80	6280	106	2857	132	1429
3	140300	29	42040	55	14930	81	6080	107	2778	133	1394
4	133400	30	40290	56	14390	82	5890	108	2701	134	1360
5	127000	31	38610	57	13870	83	5705	109	2626	135	1326
6	120900	32	37020	58	13370	84	5525	110	2554	136	1294
7	115100	33	35490	59	12900	85	5355	111	2484	137	1263
8	109600	34	34040	60	12400	86	5190	112	2416	138	1232
9	104400	35	32660	61	12000	87	5030	113	2351	139	1203
10	99500	36	31340	62	11580	88	4875	114	2287	140	1174
11	94850	37	30080	63	11170	89	4726	115	2226	141	1146
12	90450	38	28880	64	10790	90	4582	116	2167	142	1119
13	86300	39	27730	65	10410	91	4444	117	2109	143	1092
14	82300	40	26630	66	10060	92	4310	118	2053	144	1067
15	78550	41	25590	67	9710	93	4182	119	1999	145	1042
16	75000	42	24590	68	9380	94	4057	120	1947	146	1018
17	71600	43	23630	69	9065	95	3937	121	1896	147	994
18	68400	44	22720	70	8755	96	3821	122	1847	148	971
19	65350	45	21840	71	8465	97	3709	123	1799	149	949
20	62450	46	21010	72	8185	98	3601	124	1753	150	927
21	59700	47	20210	73	7910	99	3497	125	1708		
22	57100	48	19440	74	7650	100	3396	126	1664		
23	54600	49	18710	75	7400	101	3298	127	1622		
24	52250	50	18010	76	7160	102	3204	128	1581		
25	50000	51	17340	77	6925	103	3113	129	1541		

YSI H TP-53 Temperature (°C) versus Resistance (ohms, Ω) Data

-15	61020	6	22430	27	9227	48	4179	69	2055
-14	58010	7	21450	28	8867	49	4033	70	1990
-13	55170	8	20520	29	8523	50	3893	71	1928
-12	52480	9	19630	30	8194	51	3758	72	1868
-11	49940	10	18790	31	7880	52	3629	73	1810
-10	47540	11	17980	32	7579	53	3504	74	1754
-9	45270	12	17220	33	7291	54	3385	75	1700
-8	43110	13	16490	34	7016	55	3270	76	1648
-7	41070	14	15790	35	6752	56	3160	77	1598
-6	39140	15	15130	36	6500	57	3054	78	1549
-5	37310	16	14500	37	6258	58	2952	79	1503
-4	35570	17	13900	38	6026	59	2854	80	1458
-3	33930	18	13330	39	5805	60	2760		
-2	32370	19	12790	40	5592	61	2669		
-1	30890	20	12260	41	5389	62	2582		
0	29490	21	11770	42	5193	63	2497		
1	28150	22	11290	43	5006	64	2417		
2	26890	23	10840	44	4827	65	2339		
3	25690	24	10410	45	4655	66	2264		
4	24550	25	10000	46	4489	67	2191		
5	23460	26	9605	47	4331	68	2122		

APPENDIX E: Multiple Controller (RS-485) Wiring Diagram

