

CP-035HT Peltier-Thermoelectric Cold-Plate Cooler

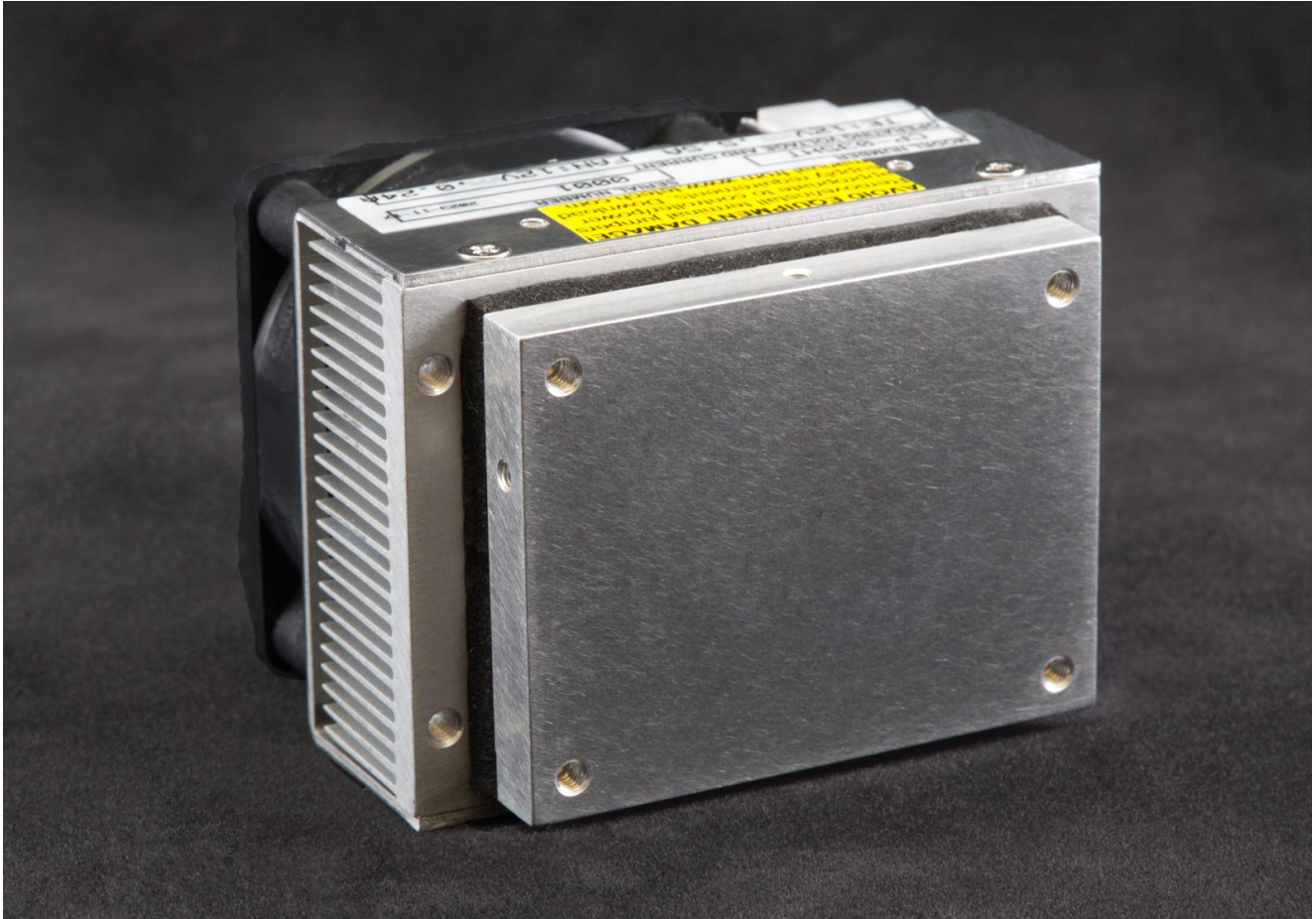

- TE Technology's smallest cold plate cooler.
- Low thermal mass reduces cool down times.
- Heats as well as cools (when used with heat & cool / bipolar controller).
- Can be used for heating up to 100 °C.
- Compatible with all of TE Technology's temperature controllers.
- An optional mounting bracket is available for converting the cooler into a bench-top version.
- Threaded holes located in the cold plate for attachment of a temperature sensor, interface plate, or object to be cooled.
- Mounting holes located in face of heat sink and sides of shroud for extra mounting options.

TE TECHNOLOGY, INC.®

Expert Engineering, Precision Manufacturing:
Quality Thermal Solutions Delivered

<https://tetech.com/> • cool@tetech.com • 231-929-3966 • 1590 Keane Drive • Traverse City, MI 49696

CP-035HT Specifications

Thermoelectric (TE) Power (typical) ^{1,3} :	12 VDC at 4.3 A
Thermoelectric (TE) Power (maximum) ^{2,3} :	12 VDC at 5.3 A
External (ambient) Fan Power:	12 VDC at 0.26 A
External (ambient) Fan Noise:	43 dBA

NEMA Rating: NA

Weight (kg): 0.39

⚠ Please review the [Thermoelectric Cooling Assembly \(TCA\) Instruction Manual](#) (or [manual in other languages](#)), [ordering information](#), and [FAQ's](#) for related technical information before purchasing or using this product.

Performance is based on unrestricted air flow to fans and from air-flow outlets. Do not operate if the heat sink or cold plate exceeds 100 °C. Do not operate fans at air temperatures below -10 °C or over 70 °C.

¹Current, at steady-state, is rated at +25 °C ambient, +25 °C internal, maximum heat removal. At -19 °C internal, the typical steady-state current is 4.1 A.

²Current, at steady-state operation under-worst case conditions, is rated at -10 °C ambient, +70 °C internal, maximum heat removal.

³Total current consumption is sum of TE current and Fan current.



RoHS Compliant
Directive 2011/65/EU

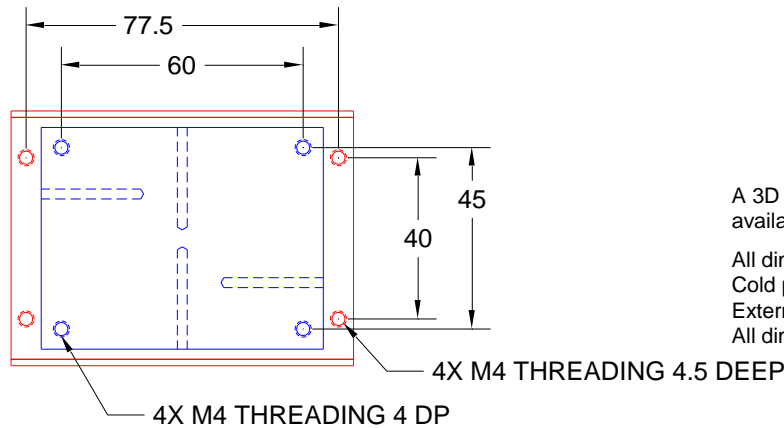

A 3D PDF, .stp, and .x_t solid models are available from the website.

All dimensions in millimeters.
Cold plate shown in blue;
External (ambient) side shown in red.
All dimensions nominal

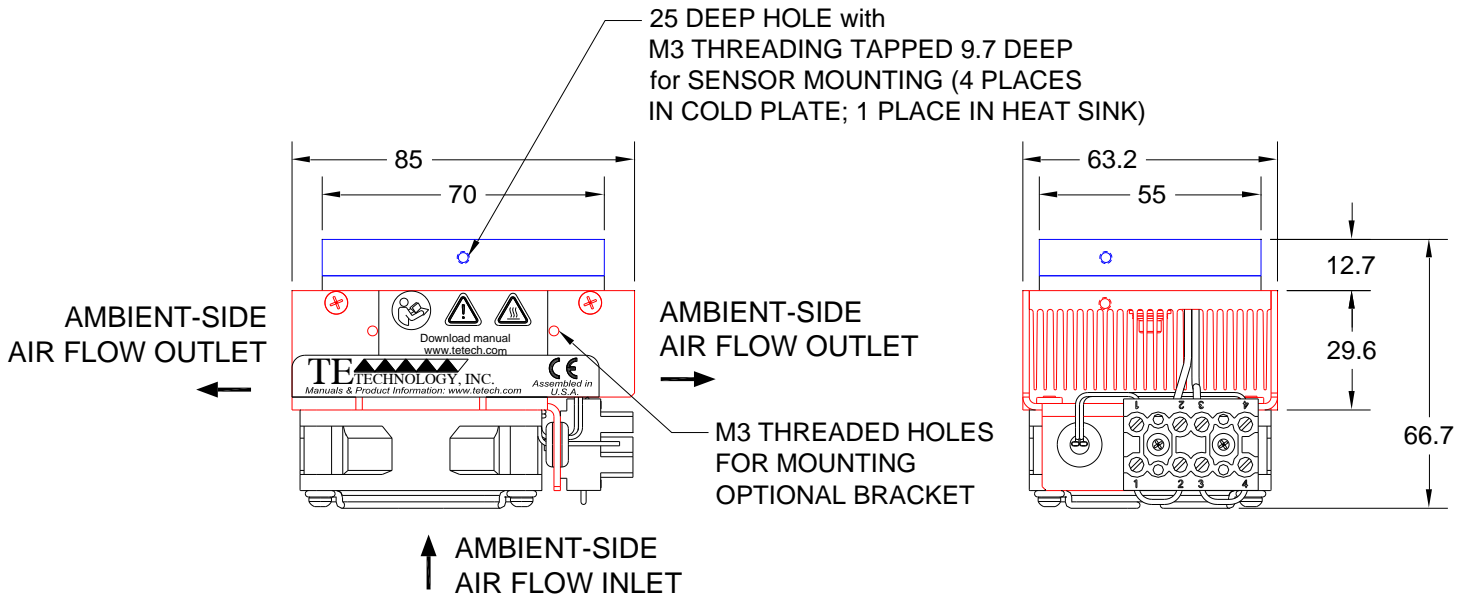

Expert Engineering, Precision Manufacturing:
Quality Thermal Solutions Delivered

<https://tetech.com/> • cool@tetech.com • 231-929-3966 • 1590 Keane Drive • Traverse City, MI 49696

CP-035HT with Optional Mounting Bracket

(for converting to bench-top use)

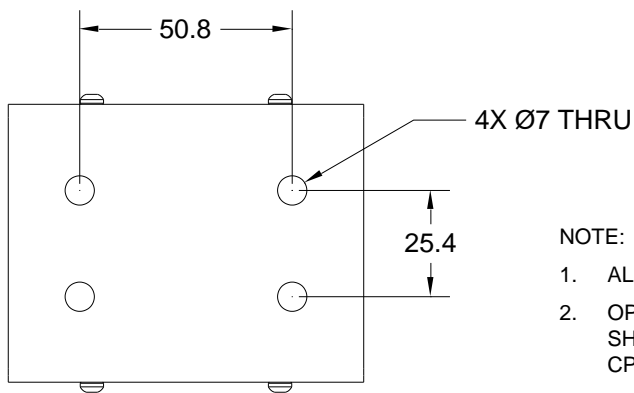
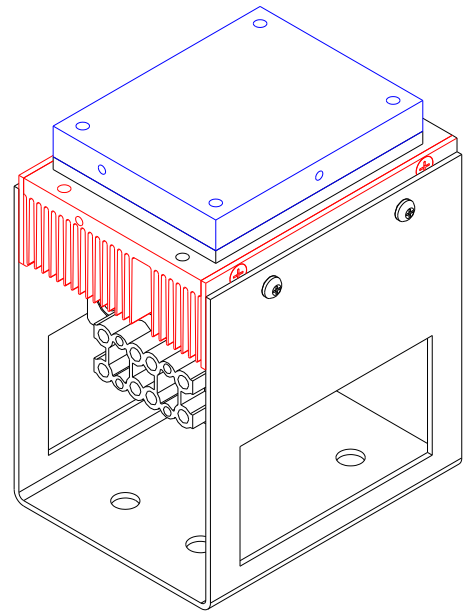
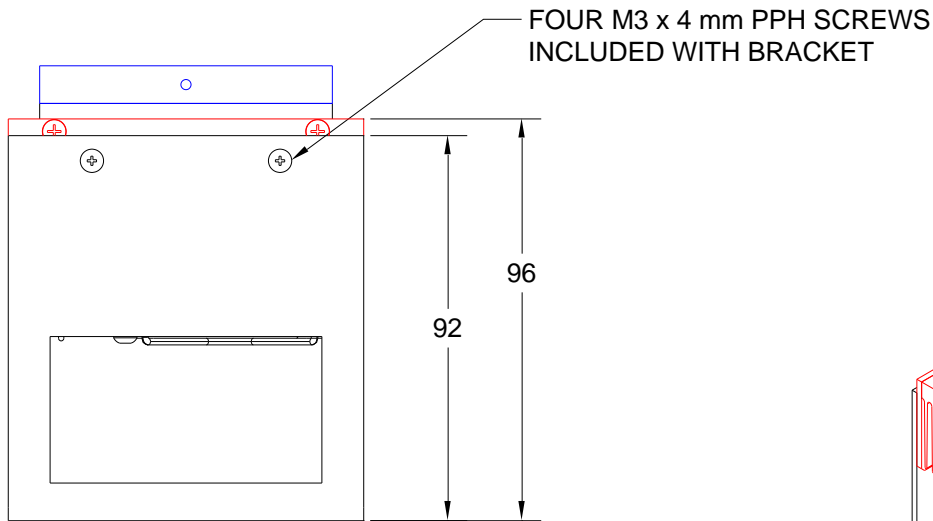

NOTE:

1. ALL DIMENSION IN MILLIMETERS
2. OPTIONAL MOUNTING BRACKET SHOWN ATTACHED TO CONVERT CP-035HT FOR BENCH-TOP USE



RoHS Compliant
Directive 2011/65/EU



Expert Engineering, Precision Manufacturing:
Quality Thermal Solutions Delivered

<https://tetech.com/> • cool@tetech.com • 231-929-3966 • 1590 Keane Drive • Traverse City, MI 49696

CP-035HT Cooling Performance Graph

(removing heat from cold plate)

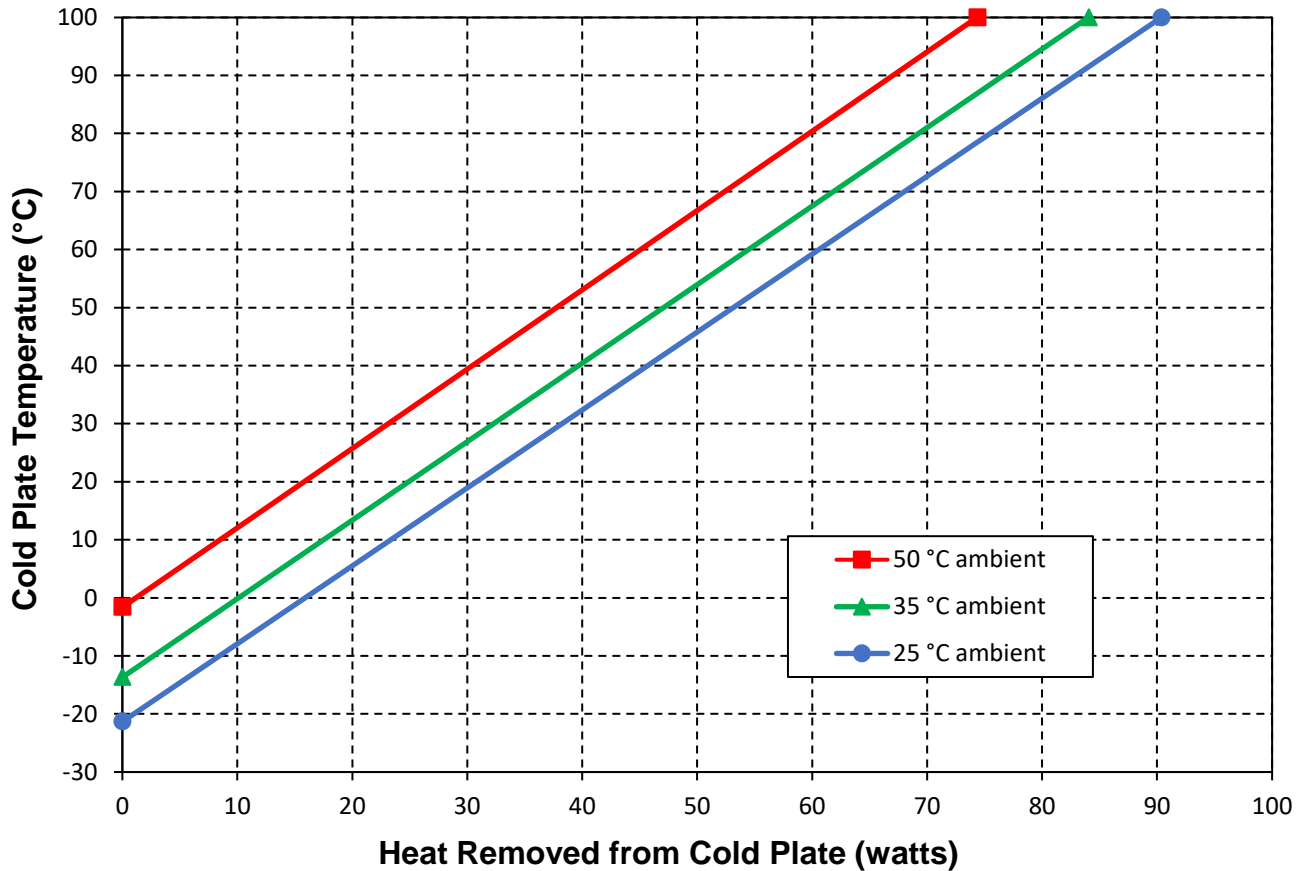

How to use the Performance Graph:

1. Select Performance Line

The diagonal lines represent cooling performance at the indicated ambient air temperature (intake temperature on the ambient-side fan). If the cooler is to operate at a different ambient, then you must sketch in a new performance line. This can be drawn parallel to one of the existing lines, using the distance between the existing lines as a scale to properly locate the new line.

2. Select Cold-Plate Temperature

Draw a horizontal line on the graph corresponding to the desired cold-plate temperature. Make the line intersect with the performance line corresponding to the ambient temperature at which the cooler is to operate.

3. Determine Cooling Capacity

The maximum amount of heat that the cooler can remove from the cold plate is determined by the intersection point (determined in the previous step). *The cooler will be able to maintain the desired temperature if the cooling capacity exceeds the heat load. If the heat load exceeds the cooling capacity then a higher capacity cooler will be needed.*

Example: You need to maintain the cold plate at 0 °C while in a 25 °C ambient. The cooler can remove a maximum of approximately 16 W of heat from the cold plate. If the heat gain from the ambient plus anything else actively generating heat exceeds this, you would need a cooler with a larger cooling capacity or multiple coolers.

TE TECHNOLOGY, INC.®

Expert Engineering, Precision Manufacturing:
Quality Thermal Solutions Delivered

<https://tetech.com/> • cool@tetech.com • 231-929-3966 • 1590 Keane Drive • Traverse City, MI 49696

CP-035HT Heating Performance Graph

(adding heat to cold plate)

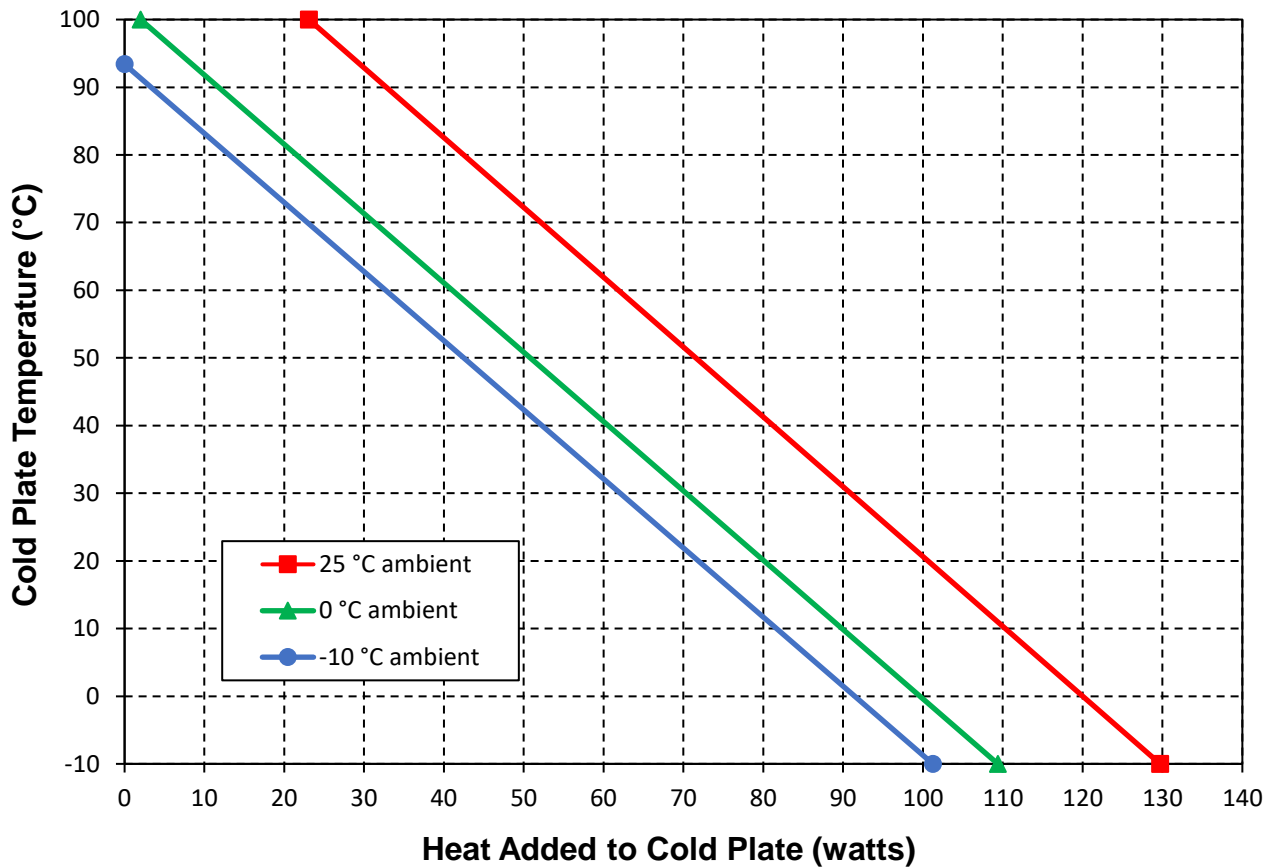

How to use the Performance Graph:

1. Select Performance Line

The diagonal lines represent heating performance at the indicated ambient air temperature (intake temperature on the ambient-side fan). If the cooler is to operate at a different ambient, then you must sketch in a new performance line. This can be drawn parallel to one of the existing lines, using the distance between the existing lines as a scale to properly locate the new line.

2. Select Cold-plate Temperature

Draw a horizontal line on the graph corresponding to the desired cold-plate temperature. Make the line intersect with the performance line corresponding to the ambient temperature at which the cooler is to operate.

3. Determine Heating Capacity

The maximum amount of heat that the cooler can add to the cold plate is determined by the intersection point (determined in the previous step). *If the heat added to the cold plate (including heat generated by equipment on the cold plate) is greater than the heat loss from the cold plate, then the cooler will be able to heat to the desired temperature.*

Example: You need to maintain the cold plate at 30 °C while in a 25 °C ambient. The cooler can add up to approximately 91 W of heat to the cold plate. If the heat dissipation from the cold plate to the ambient exceeds this (plus anything else generating heat), you would need multiple coolers or a cooler with a larger heating capacity.



Expert Engineering, Precision Manufacturing:
Quality Thermal Solutions Delivered

<https://tetech.com/> • cool@tetech.com • 231-929-3966 • 1590 Keane Drive • Traverse City, MI 49696

CP-035HT Fan Speed Connections

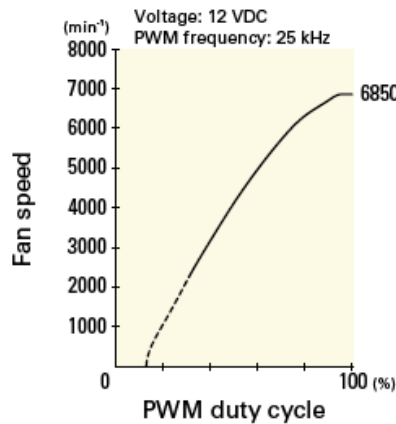
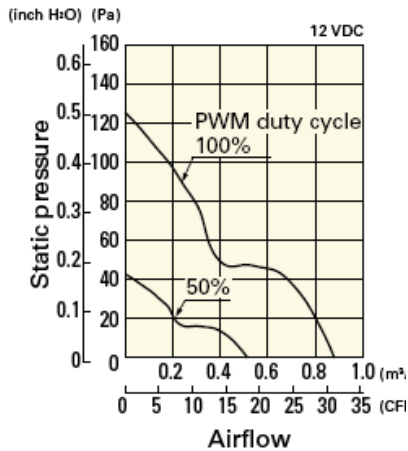

The fan speed operates at 100% as shipped. DO NOT OPERATE THE CP-035HT IN COOLING MODE WITH A PWM DUTY CYCLE OF LESS THAN 50%. DO NOT ALLOW HEAT SINK OR COLD PLATE TEMPERATURES TO EXCEED 100 °C.

The fan speed can be controlled using pulse width modulation at a recommended 5 kHz to 25 kHz frequency range, applied to the brown fan wire. The TC-720 temperature controller can be used to provide this PWM signal to reduce the audible noise at low cooling demands (use 5400Hz frequency setting).

The yellow wire provides fan-speed sensing. Consult with TE Technology if you wish to use this feature.

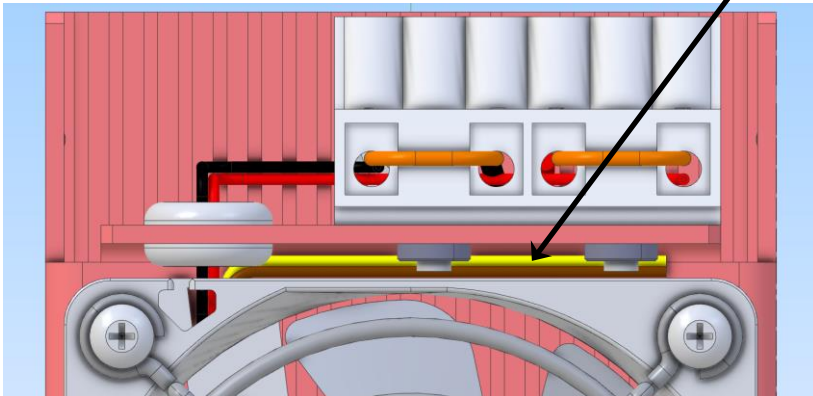

Brown Wire: Speed Control
Yellow Wire: Speed Sensor

The brown and yellow wires are usually not used and are therefore wrapped in heat shrink.

If using these features, carefully cut away the heat shrink. Additional wire length can be spliced on as needed.



Expert Engineering, Precision Manufacturing:
Quality Thermal Solutions Delivered

<https://tetech.com/> • cool@tetech.com • 231-929-3966 • 1590 Keane Drive • Traverse City, MI 49696

Terminal Block Configuration for Continuous Operation at Full Power *As-Shipped Configuration 1 of 2*

1

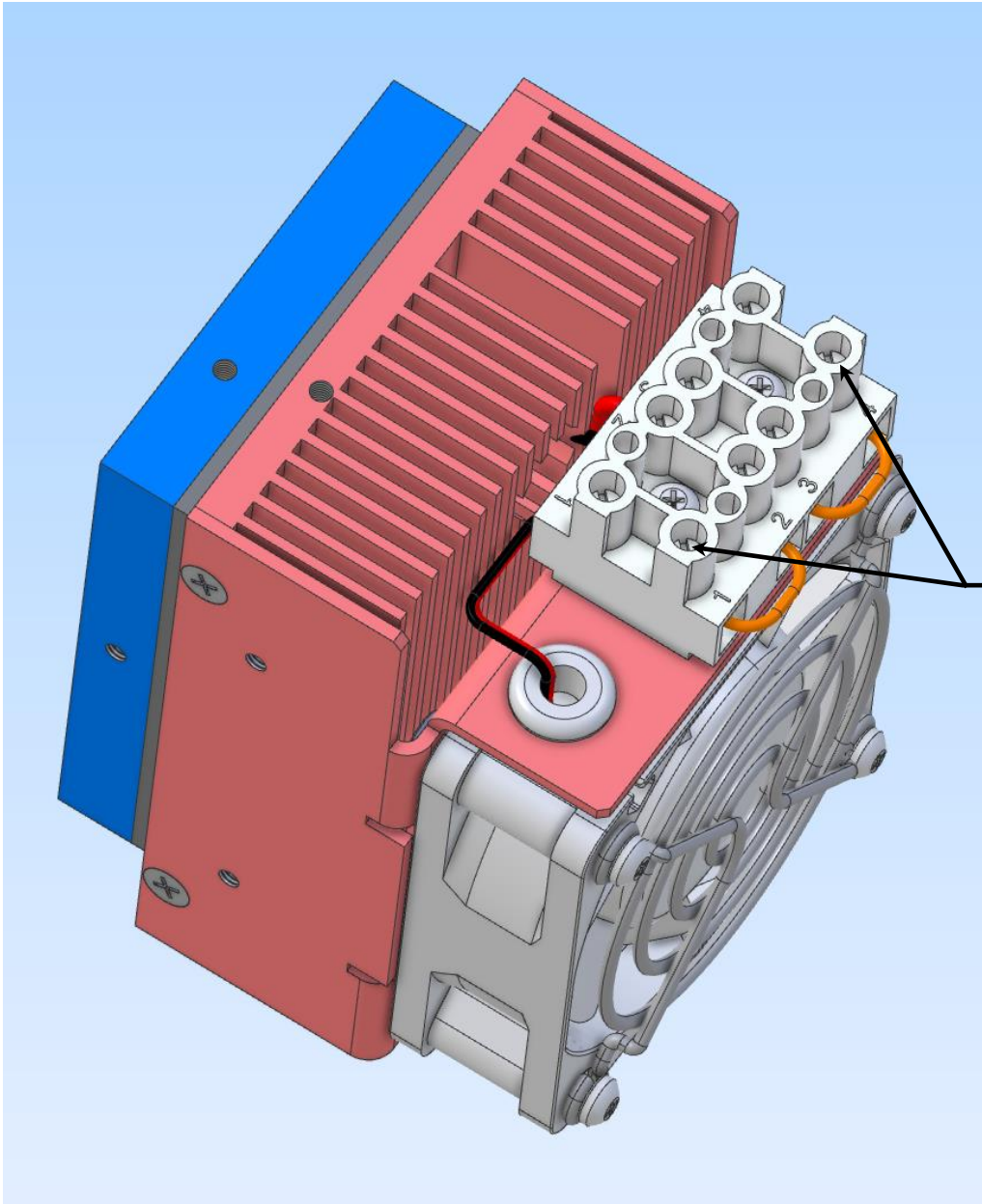

LOOSEN TWO SCREWS
KEEP JUMPERS INSTALLED

TE TECHNOLOGY, INC.®

Expert Engineering, Precision Manufacturing:
Quality Thermal Solutions Delivered

<https://tetech.com/> • cool@tetech.com • 231-929-3966 • 1590 Keane Drive • Traverse City, MI 49696

Terminal Block Configuration for Continuous Operation at Full Power

2 of 2

2

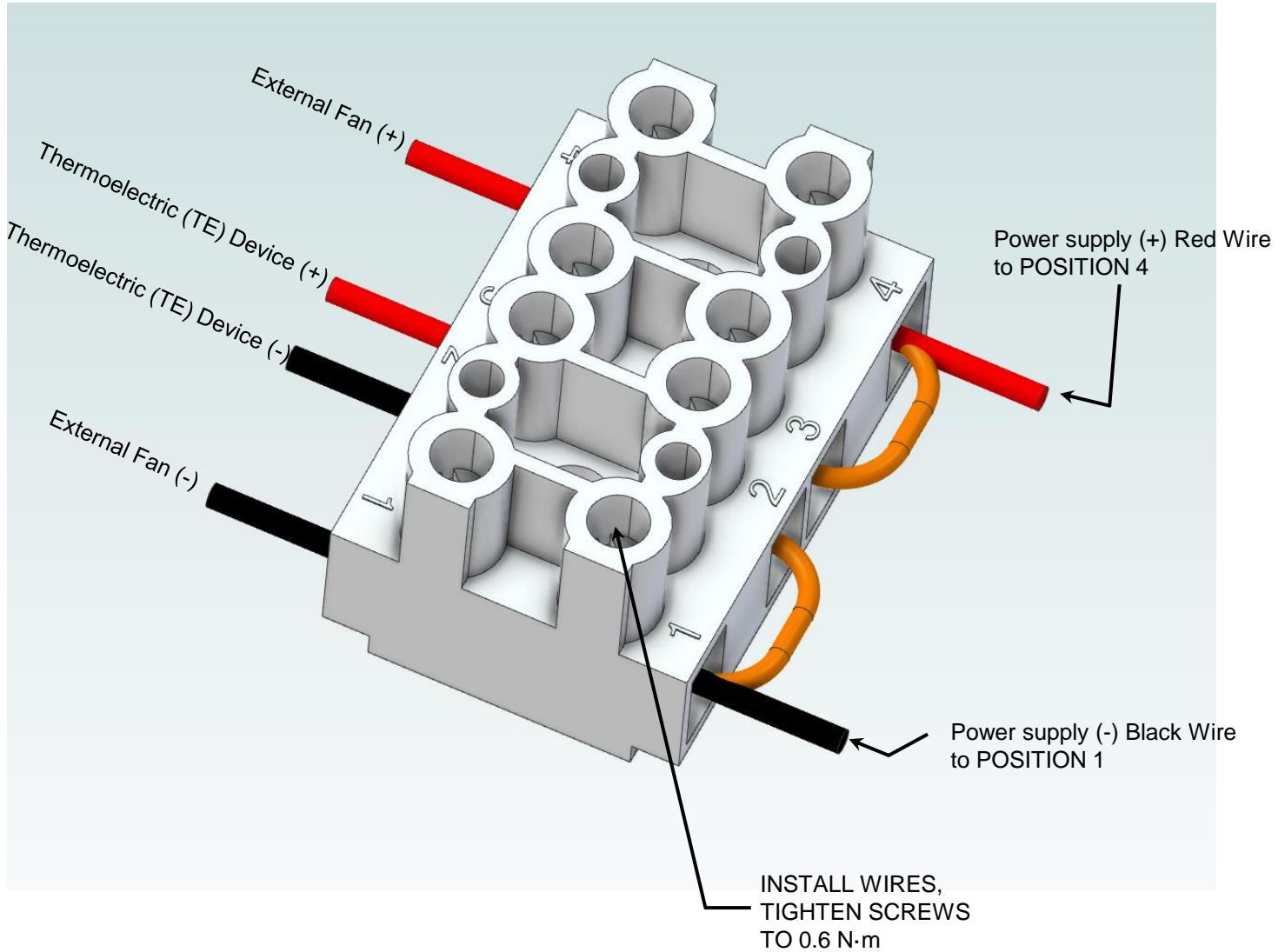

Expert Engineering, Precision Manufacturing:
Quality Thermal Solutions Delivered

<https://tetech.com/> • cool@tetech.com • 231-929-3966 • 1590 Keane Drive • Traverse City, MI 49696

Terminal Block Configuration for Operation with Temperature Controller

1 of 2

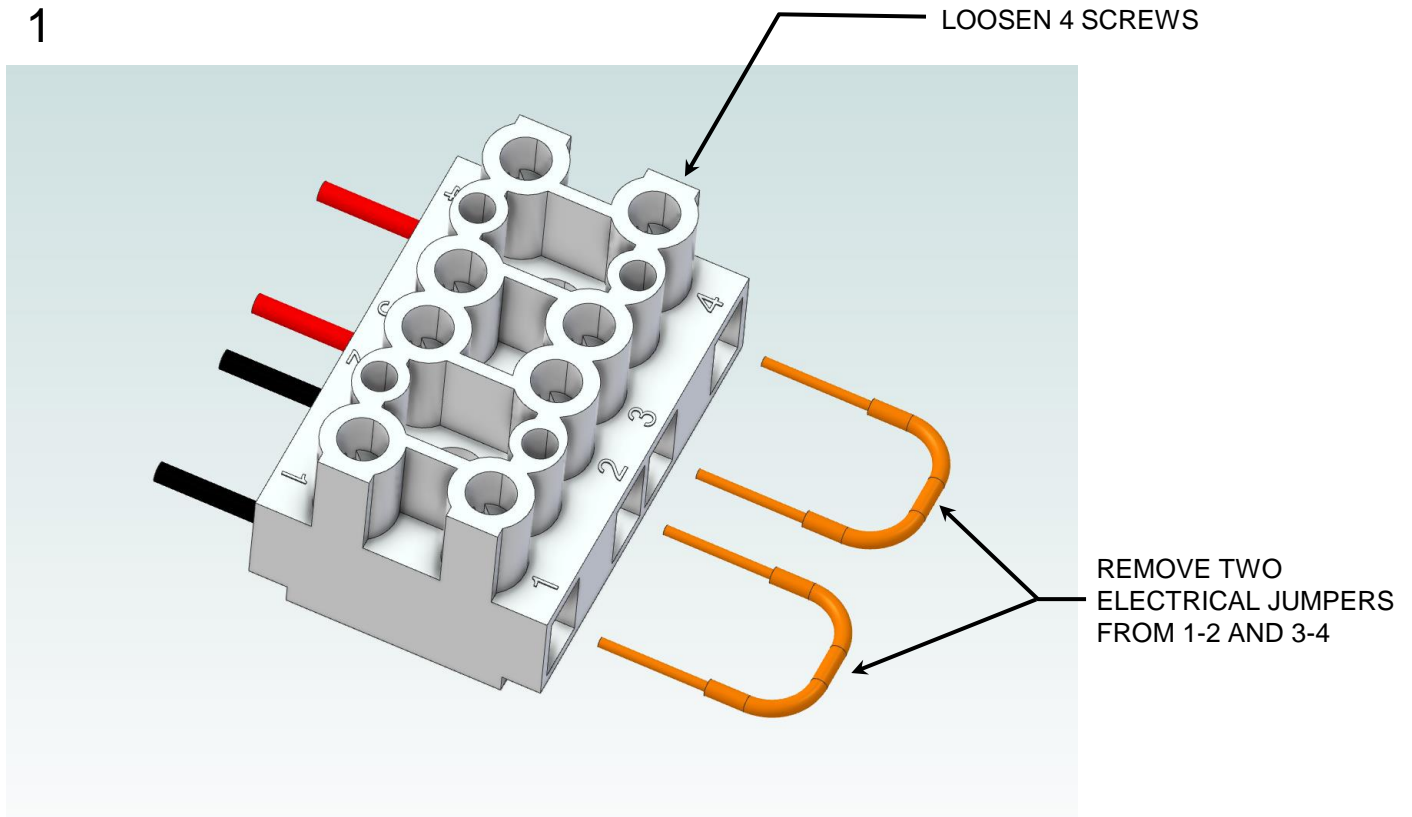

TE TECHNOLOGY, INC.®

Expert Engineering, Precision Manufacturing:
Quality Thermal Solutions Delivered

<https://tetech.com/> • cool@tetech.com • 231-929-3966 • 1590 Keane Drive • Traverse City, MI 49696

Terminal Block Configuration for Operation with Temperature Controller

2 of 2

2

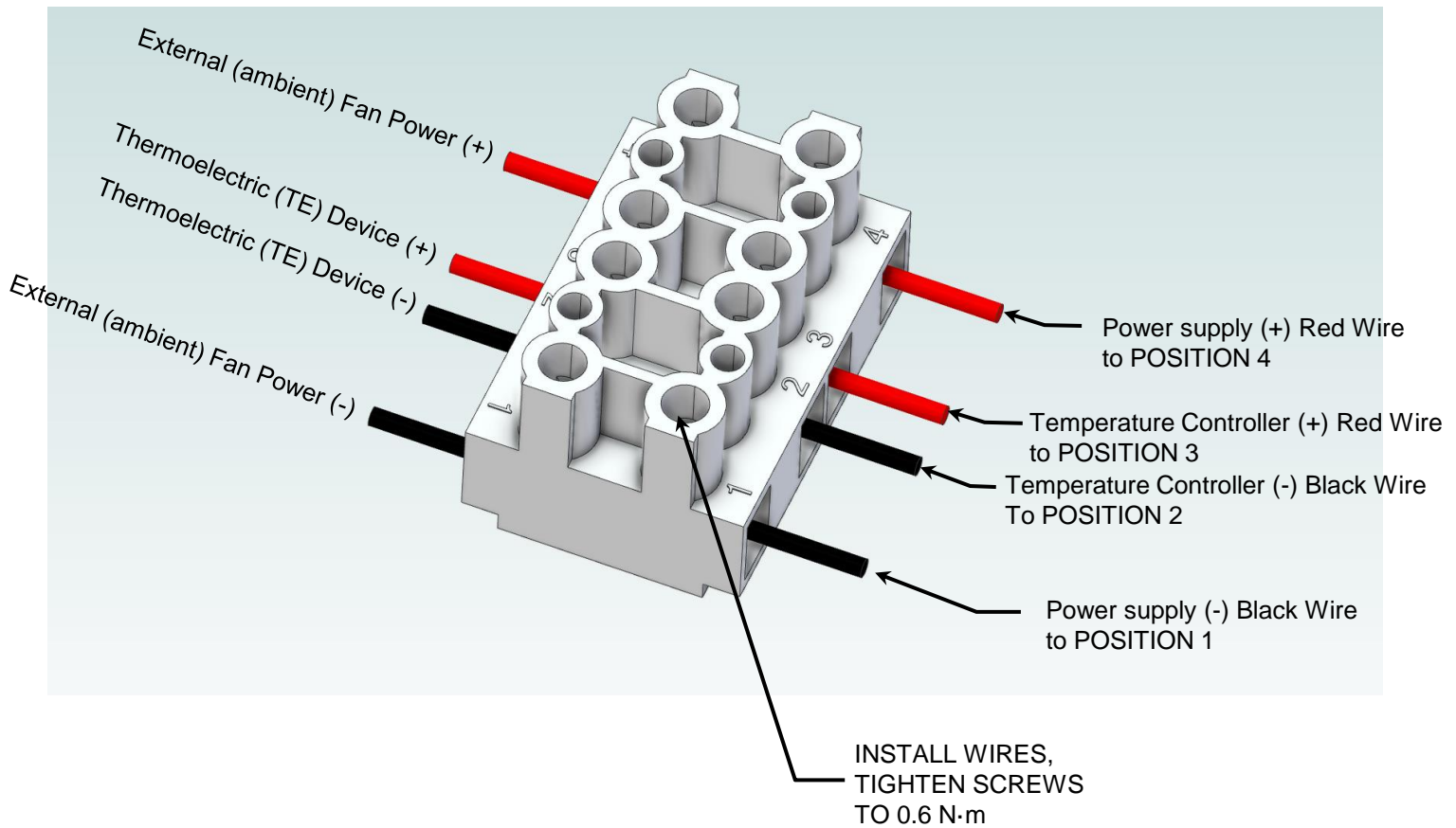

Expert Engineering, Precision Manufacturing:
Quality Thermal Solutions Delivered

<https://tetech.com/> • cool@tetech.com • 231-929-3966 • 1590 Keane Drive • Traverse City, MI 49696