

**Operation Manual**

**For**

**Model TC-24-25 RS232**

**Thermoelectric Cooler**

**Temperature Controller**

**November 8, 2005**  
**Drawing #3599 Rev. F**

**TE**  **TECHNOLOGY, INC.**

**1590 Keane Drive**  
**Traverse City, MI 49686-8257**  
**<http://www.tetech.com>**

**Phone: (231) 929-3966**  
**Fax: (231) 929-4163**  
**e-mail: [cool@tetech.com](mailto:cool@tetech.com)**

# Table of Contents

Features .....	3
General Description.....	4
Technical Description.....	4
Set-Up Instructions.....	6
1.0 Setup.....	6
2.0 Configure.....	7
3.0 Tuning .....	9
4.0 Calibration.....	10
5.0 Controller Operation.....	10
6.0 Custom Software .....	11
Controller Wiring Diagram .....	12
Expansion Connector Wiring Diagram .....	13
Mechanical Package Drawing .....	14
Block Diagram .....	15
RS232 Communications Connections.....	16
APPENDIX A Troubleshooting Communications Port .....	17
APPENDIX B PID Tuning.....	18
APPENDIX C Serial Communications .....	20
APPENDIX D Thermistor Styles for TC-24-25 RS232.....	32

**Notice:** Improper tuning of this temperature controller (or any temperature controller) can lead to excessive thermal cycling and/or overheating of the thermoelectric device, either of which are known to reduce the lifetime of any thermoelectric device. Care should be taken to prevent the temperature of the thermoelectric device from going beyond the range specified by the device manufacturer. Care should also be taken so that any thermal cycling of the thermoelectric device is a result of changes in the controller’s set-point temperature and not instability at a given set point due to improper selection of the tuning variables.

In no event shall TE Technology, Inc. be liable for any damages whatsoever (including without limitation, damage for loss of business profits, business interruption, loss of business information, or any other pecuniary loss) arising out of the use or inability to use this TE Technology, Inc. product, even if TE Technology, Inc. has been advised of the possibility of such damages.

## Features

- Input voltage from (12 to 28) VDC
- Self-contained, (0.1 to 25) A current rating
- Computer programmable via RS232 communications port
- Bi-directional, solid state H-bridge operation for heating and cooling applications
- Control temperature of  $-20\text{ }^{\circ}\text{C}$  to  $+100\text{ }^{\circ}\text{C}$  using MP-2379 thermistor (supplied with controller)
- Proportional (P), Integral (I) and Derivative (D) control that can be selected as P, PI, PD or PID; or Deadband (on/off) with an adjustable hysteresis
- Temperature resolution of  $0.1\text{ }^{\circ}\text{C}$  or  $0.1\text{ }^{\circ}\text{F}$
- Control stability of  $\pm 0.1\text{ }^{\circ}\text{C}$  or  $\pm 0.1\text{ }^{\circ}\text{F}$  (when controlling a cold plate)
- Pulse width modulation of output:
  - Selectable modulation frequency of 675 Hz or 2700 Hz
  - Controls up to 680 W
- Set temperature selectable:
  - Computer set with controller stand alone operation
  - Remote user set temperature potentiometer
  - 0 mA to 20 mA current loop
  - 0 VDC to 5 VDC adjustable range
  - Differential temperature control
- No computer programming experience required to use the communications software program (Supplied software is compatible with Windows 95/98/XP/NT)
- Command set is provided so programmers may create their own software interface or embedded controller applications
- Versatile alarm system:
  - Computer configurable alarms for 5 VDC at 25 mA
  - Alarm cancel: selectable via computer-software communication or remote contacts
  - Second sensor also configurable as a heat-sink over-temperature shut-down
- Non-volatile memory retention of parameters (1,000,000 write cycles maximum; see command #31 in Appendix C for further details.)
- Operating temperature range of  $0\text{ }^{\circ}\text{C}$  to  $65\text{ }^{\circ}\text{C}$
- Storage temperature range of  $-55\text{ }^{\circ}\text{C}$  to  $+105\text{ }^{\circ}\text{C}$

## General Description

The TC-24-25 RS232 is a bi-directional control for independent thermoelectric coolers or in conjunction with auxiliary or supplemental resistive heaters for both cooling and heating applications. The H-bridge configuration of the solid state MOSFET output devices allows for the bi-directional flow of current through the thermoelectric coolers. Highly efficient N-channel output devices are used for this control mode.

This controller is programmable via an RS232 communication port for direct interface with a compatible computer. The easily accessible communications link permits a variety of operational mode configurations. Field selectable parameters or data acquisition in a half duplex mode can be performed. This controller will accept a communications cable length in accordance with RS232 interface specifications. The supplied software is compatible with Windows 95/98/XP/NT.

Once the desired set parameters are established, the TC-24-25 RS232 can be disconnected from the computer, and it becomes a unique, stand-alone controller. All parameter settings are retained in non-volatile memory.

The user friendly, communications software requires no prior programming experience to establish operation. A command set is provided for qualified personnel to program a software interface or use as an embedded control.

Mechanically, the control printed circuit board is mounted to a metal bracket that is suitable for either horizontal or vertical orientation. Input and output connections are accessible via screw type terminal strips and fast-on terminals.

## Technical Description

The TC-24-25 RS232 is capable of operating from an input supply voltage of (12 to 28) VDC, common to many available thermoelectric coolers. The self-contained MOSFET output devices deliver load currents from (0.1 to 25) A. (NOTE: consult appropriate installation instructions for power supply and heat sinking requirements for high current operation). This unit will control total load power up to 680 W with a finite temperature resolution of 0.1 °C or 0.1 °F.

The output signal to the thermoelectric cooler is pulse-width modulated and can be set for either 675 Hz or 2700 Hz operation. Pulse-width modulation (PWM) averages the amount of energy provided to the module and reduces the extreme temperature excursions that are experienced with a thermostatic control system. This tends to extend the life and reliability of the thermoelectric devices. The PWM control scheme affords control accuracy to within  $\pm 0.1$  °C or  $\pm 0.1$  °F at the control sensor.

The controller tuning structure allows designation of a variety of control features:

- 1) The Computer Set Value provides for manual control of the output from 0% to  $\pm 100\%$  of load power.
- 2) Proportional bandwidth (P) in degrees, Integral reset (I) in repeats per minute, and the Derivative rate (D) in minutes may be configured for P, PI, PD, or PID control.

3) Deadband control (on/off) with an adjustable hysteresis may be selected. However, this control mode is not generally recommended.

4) Differential temperature control is provided when two input sensing thermistors are used. The unit will control the differential between Input 2 (reference temperature) and Input 1 (actual system temperature).

A control temperature range of  $-20\text{ }^{\circ}\text{C}$  to  $+100\text{ }^{\circ}\text{C}$  is standard when using TE Technology's standard thermistor sensor probe for the primary set temperature. Additional external set temperature input types may be selected. As mentioned above, a second thermistor can be used for differential control (or it could be used for alarm condition sensing). In addition, the controller could use a remote set temperature potentiometer, a (0 to 5) VDC signal, or a (0 to 20) mA current loop. These secondary inputs are used to define and "map" the secondary input to an adjustable temperature range in order to remotely control the set temperature. All temperatures may be consistently displayed in  $^{\circ}\text{C}$  or  $^{\circ}\text{F}$ .

Two types of control output modes may be selected. This determines the direction of the current flow through the thermoelectric cooler during the heat cycle. This current flow may be from Wire Point WP1+ to Wire Point WP2-. Alternatively, this current flow may be reversed from WP2+ to WP1- as selected in the configuration menu.

Several alarm settings may be selected, some of which provide a 5 VDC output, rated for 25 mA of current for alarm signaling. The settings can be selected for no alarm function, tracking alarm, and fixed-value alarm. Alarm set temperature values are entered in the setup menu. The computer-controlled selection is available for additional embedded controller input/output options. The alarm setup menu also provides for selection of an alarm latching condition. The alarm sensor may be either the control temperature sensor or a secondary thermistor sensor.

The various alarms have the ability to determine the status of the output power to the thermoelectric cooler or auxiliary heater. Power may be maintained during an alarm condition or the main power may be shut down.

# Set-Up Instructions

## 1.0 Setup

*NOTE: the maximum allowable ambient temperature for the controller is 65 °C. Furthermore, the maximum allowable temperature of the controller base (underneath the transistor-mounting area) is 80 °C.*

- 1.1 Make sure the computer is off and the controller is un-powered. Connect the RS232 Communications Port from the controller (JP3) to the RS232 input (Serial Communications Port) on the computer. Pin 1 of JP3 is the controller's RX, Pin 2 of JP3 is the controller's TX, and Pin 3 of JP3 is the controller's shield. Pin 1 of JP3 should connect to the clear wire on the RS-232 cable, Pin 2 of JP3 should connect to the red wire on the RS-232 cable, and Pin 3 of JP3 should connect to the black wire on the RS-232 cable. See "*RS232 Communications Connections*" for further information.
- 1.2 Attach the thermistor to the control location. Generally, this is the cold side of the cooler rather than the part itself that is to be cooled/heated. This provides better control stability. As much wire length of the thermistor should be thermally connected to the cold side as possible so that the thermistor and its wire leads are as equivalent in temperature as possible. This can be accomplished by using aluminum tape placed over the wire leads and adhered to the cold side of the cooler. This will help eliminate errors resulting from heat conducting along the wire leads and affecting the sensor reading.

The standard thermistor supplied with the TC-24-25 RS232 is the MP-2379. Appendix D "*Thermistor Styles for TC-24-25 RS232*" shows dimensional data on the MP-2379 and other thermistor styles readily available as well as temperature-resistance data. If you are using the MP-2379, it is recommended that you use thermal grease (such as TE Technology TP-1) between the thermistor and the surface to which it is mounted.

If you want to use thermistors that have different resistance-temperature curves than the standard thermistor, it can be done as long as the operating resistance range is within that of the standard thermistor. The thermistor should be a negative temperature coefficient device. Because the temperature controller is really measuring the thermistor's resistance and converting this to a temperature, the temperature controller will be fooled into thinking that the thermistor is at a different temperature than it really is, and the Set-Temperature will be skewed accordingly. A loss of resolution and control stability may occur as a result. The user assumes all risks associated with making any substitutions and TE Technology assumes no liability whatsoever for the operation of the controller when a non-standard thermistor is used.

- 1.3 Connect the appropriate DC power (12 to 28 volts) to the controller between WP3+ and WP4- and the thermoelectric cooler between WP1 and WP2 in accordance with the "*Controller Wiring Diagram*." *NOTE:* Generally there is approximately a 0.5 to 1.3 V drop from the power supply to the thermoelectric modules. You may want to adjust the power supply accordingly to ensure full power is delivered to the cooler when needed.

- 1.4 Turn power on to both the computer and power supply (which in turn powers up the controller). The on-board green LED will flash at a steady rate to indicate that the controller is energized correctly.
- 1.5 Insert the TC-24-25 RS232 software disk into the computer floppy-disk drive. To run the software from the floppy disk, select START, RUN from your Windows Desktop and then enter A:\TC-24-25 RS232.exe. This will load the software into your computer's RAM. Alternatively, copy the TC-24-25 RS232.exe file to your hard-disk drive and run the program from there.
- 1.6 The Main Menu screen will appear on your computer monitor. All selections are made from this menu screen. In the PC COMMUNICATIONS section, select the RS232 comm port (1 through 4) to which the controller is connected by using the SELECT COMM PORT menu key. After making this selection, click on the INITIALIZE button.
- 1.7 NOTE: If you receive an error message, please refer to Appendix A “*Troubleshooting Communications Port.*”

## **2.0 Configure**

- 2.1 In the CONFIGURE section, the various selections are used to establish the custom operating criteria for the controller. *NOTE: To avoid damage to the thermoelectric cooler, confirm that OFF is selected in the OUTPUT ON/OFF menu key and then click the Send Box Values button prior to proceeding!*
- 2.2 First, select the PWM OUTPUT TIMEBASE menu key. Options for SLOW TIMEBASE 675Hz or FAST TIMEBASE 2700Hz will appear. Select the option that is appropriate for you. Generally, 675 Hz will work fine and is the recommended default.
- 2.3 Next, click on the SET TEMP TYPE INPUT 2 menu key to reveal the options available. COMPUTER SET VALUE is to be selected when using the software to set the desired control temperature. The other selections, POTENTIOMETER SET, 0 TO 5vdc SET, and 0 TO 20ma SET, are for external set temperature adjustments. Refer to the “*Controller Wiring Diagram*” and the “*Block Diagram*” for additional information. The controller default setting for these options is the full range of the thermistor input sensor. The DIFF.SET=INP2+FIXED SET establishes an actual set temperature that is the sum of the temperature sensed by the optional, secondary thermistor input sensor and the temperature entered as the FIXED SET TEMP value. This allows the controller to maintain a constant temperature difference between the primary thermistor temperature and the secondary thermistor.
- 2.4 Enter the SET TEMP HIGH RANGE and SET TEMP LOW RANGE values. These values are used to linearly scale the temperature range that you are controlling within to the full range of the external input. The set limit values must be within the temperature range that controller is capable of controlling to.

For example, suppose you are using a (0 to 5) VDC external input to control the set temperature. Suppose further that you enter -20 °C for the SET TEMP LOW RANGE and +100 °C for the SET TEMP HIGH RANGE. This sets up a linear scale of 5 V per 120 °C, or 0.0417 V/°C. So, to control to 10 °C, for example, you would set the external input voltage to 1.25 V.

- 2.5 Click the CONTROL TYPE menu key and select which type is appropriate for your application. The DEADBAND CONTROL is an on/off control and PID CONTROL is a proportional/integral/derivative control. COMPUTER CONTROL allows a constant, fixed percentage of power to be applied to the thermoelectric cooler. Generally, DEADBAND CONTROL should not be used unless care is taken to prevent the thermoelectric cooler from being damage by excessive thermal cycling.
- 2.6 Clicking on the CONTROL MODE menu key permits the selection of either HEAT WP1+ AND WP2- or HEAT WP2+ AND WP1-. These selections establish the polarity for the heating mode of the thermoelectric cooler. This selection allows you to reverse the current flow in the thermoelectric cooler without having to change the wiring.

***NOTE:** For TE Technology's standard products, the TE+ (red) wire should be attached to WP2 and the TE- (black) wire should be attached to WP1 as shown in the "Controller Wiring Diagram." The CONTROL MODE should then be set to HEAT WP1+ and WP2-.*

- 2.7 The ALARM TYPE menu key permits the selection of available alarm options. NO ALARM PICKED indicates that no alarm parameters are desired. SET TRACKING ALARMS allows an alarm to be set with respect to the set temperature. It will move accordingly with a change of the temperature setting. This option can be used for a high alarm, low alarm, or both settings. FIXED VALUE ALARMS permits the setting of a fixed, absolute temperature either above or below the set point temperature or both. COMPUTER CONTROLLED ALARM is not an actual alarm, but provides for user activation of the alarm relay via the computer software. The "Expansion Connector Wiring Diagram" shows how customer-supplied LED's can be installed to signal various alarm conditions.
- 2.8 The POWER OUT SHUT DOWN IF ALARM menu key provides two selections. NO SHUT DOWN IF ALARM will let the controller continue to control to the set temperature. MAIN OUT SHUTDOWN IF ALARM shuts off power to the cooler when an alarm condition exists.
- 2.9 Associated with the ALARM TYPE configuration are the HIGH ALARM SETTING, LOW ALARM SETTING, and the ALARM DEADBAND settings. If an alarm type has been selected, enter the desired high and low temperature values that you want to have trigger an alarm condition. The ALARM DEADBAND option sets the hysteresis of the alarm values from 0.1 degrees to 100 degrees.
- 2.10 The ALARM LATCH menu key permits the selection of ALARM LATCH OFF or ALARM LATCH ON. If ALARM LATCH OFF is selected, the controller will automatically reset if the alarm condition self-corrects when the corresponding temperature returns back to the temperature defined by the ALARM DEADBAND and alarm setting. If ALARM LATCH ON is selected, the



controller will maintain the alarm condition until it is manually cleared. When ALARM LATCH ON is selected, and if an alarm condition exists, the alarm latch can be reset by clicking the SEND LATCH CLEAR button.

- 2.11 The SENSOR TYPE menu key allows for the selection of different types of temperature sensors for two different control ranges. Select the TS-67 sensor type when using the standard MP-2379 sensor or other sensors listed in Appendix D “*Thermistor Styles for TC-24-25 RS232.*” This will provide a control range of -20 °C to +100 °C. However, remember that depending on the type of cooler you have, it might not be suitable for operation at temperatures greater than 70 °C. The TS-141 sensor type is selected when you need a -40 to +70 °C control range. This sensor type is non-standard but can be provided. Consult with TE Technology if you need this control range.
- 2.12 The CHOOSE SENSOR FOR ALARM menu key allows for the selection of either the CONTROL SENSOR the thermistor or INPUT 2 SENSOR thermistor be used for the alarm. (Note: The INPUT 2 SENSOR thermistor cannot be used if you are using a potentiometer or voltage/current levels to control the set point.) The INPUT 2 SENSOR thermistor can be attached to the heat sink in order to detect over-temperature conditions.
- 2.13 The CHOOSE DEG C OR DEG F menu key permits the selection of displaying °F or °C.
- 2.14 The EEPROM WRITE ENABLE, located just below the CONFIGURE SECTION, can be checked or unchecked depending on your requirements. See Appendix C, command #31 for more information on EEPROM WRITE ENABLE.
- 2.15 Review all of your controller configuration selections. If all the configuration selections are correct for your application, select the Send Box Values button to download these settings to the controller.

### **3.0 Tuning**

- 3.1 You are now ready to tune the controller. All selections for this portion will occur in the TUNING section of the controller software. The various constants required by the controller to optimize the system performance are entered in this section.
- 3.2 The FIXED SET TEMP is the set temperature value entered in degrees. This temperature must be within the range of the selected input sensor or the limits of low and high set ranges from the controller configuration setup. Also, verify that the cooler is capable of safely operating at the entered set temperature. This is particularly important if you are heating. While you can control to +100 °C using the standard thermistor, many coolers are rated for at most 80 °C.

If you selected COMPUTER CONTROL in the CONTROL TYPE menu key under the CONFIGURE section, the values that can be entered in the FIXED SET TEMP box range from -12.0 to +12.0. This corresponds linearly to a fixed percentage of power output where -12.0 equals -100% power and +12.0 equals +100% power.

- 3.3 PROPORTIONAL BANDWIDTH is the temperature band in which 0% to 100% power will be applied to the cooler. The acceptable bandwidth values that may be entered are 1° to 100°. See Appendix B “*PID Tuning*” for additional information on settings.
- 3.4 INTEGRAL GAIN is used to slowly change the output power until the difference between the actual temperature and set temperature is zero. This value is expressed in repeats per minute, and the acceptable values that may be entered are 0.01 to 10 repeats per minute.
- 3.5 DERIVATIVE GAIN senses the rate of rise or fall of the system temperature and adjusts the cycle time of the controller to minimize overshoot or undershoot. This value is expressed in cycle rates per minute, and the acceptable values that may be entered are 0.01 to 10 cycles per minute.
- 3.6 CONTROL DEADBAND is the temperature band where the controller is turned on and off by either rising or falling temperatures where no heating or cooling takes place. This band is expressed in degrees, and the acceptable values that may be entered are 0.1 to 100.
- 3.7 Review the tuning parameters for correctness and then click the Send Box Values button to download these constants to the controller.

#### **4.0 Calibration**

- 4.1 The CALIBRATE section provides additional variables that can be used to fine tune your system’s operation. You may want to try controlling with the initial settings prior to entering values in this section.
- 4.2 INPUT 1 OFFSET is a manual method of compensating for the sensor 1 temperature and actual control temperature.
- 4.3 INPUT 2 OFFSET is a manual method for compensating for the sensor 2 temperature and actual temperature.
- 4.4 HEAT SIDE MULTIPLIER is a 0.01 to 2.00 numerical multiplier that compensates for the non-symmetrical response of the thermoelectric cooler between the heat and cool modes.
- 4.5 If you have entered values in the CALIBRATE box and they are desired settings, click the Send Box Values button to download these constants to the controller.

#### **5.0 Controller Operation**

- 5.1 Initial set-up of the TC-24-25 RS232 controller is complete.
- 5.2 Select ON in the OUTPUT ON/OFF menu key located in the CONFIGURE section. Then click the Send Box Values in the CONFIGURE section to turn the controller on.
- 5.3 Click the SAMPLE button to monitor the CONTROL SENSOR’s temperature. This temperature is indicated in the TEMP box. If you have an INPUT 2 SENSOR thermistor attached, its temperature is indicated in the SECOND SENSOR box.

5.4 If all of the settings are satisfactory, you can turn off the computer and power supply, disconnect the controller from the RS-232 port, and turn back on the power supply. The controller remembers its last settings on EEPROM and will resume control based on that.

## **6.0 Custom Software**

The controller does not specifically have to be used with the software that is provided. You could also use commercial software such as LabVIEW from National Instruments. This might be useful if you wanted to control a specific temperature profile over a particular amount of time. This is accomplished by communicating through the RS-232 port of the computer using the command set for the controller. The command set is given in Appendix C “*Serial Communications.*”

# Controller Wiring Diagram

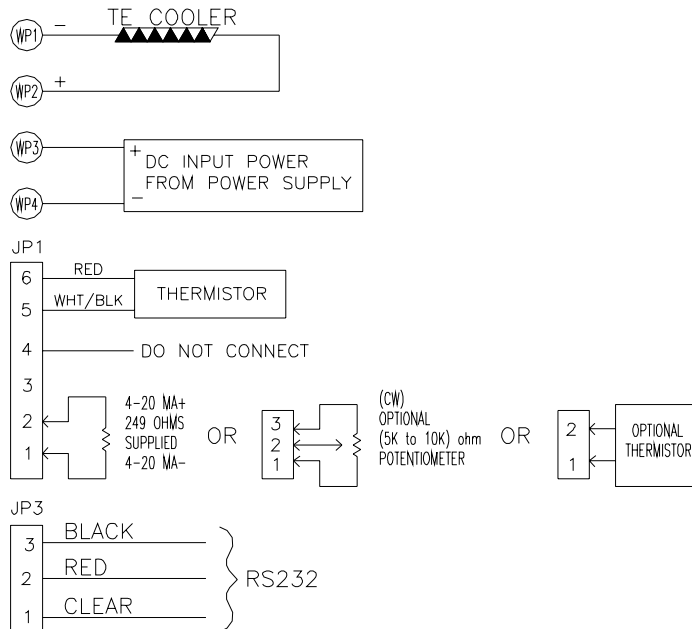
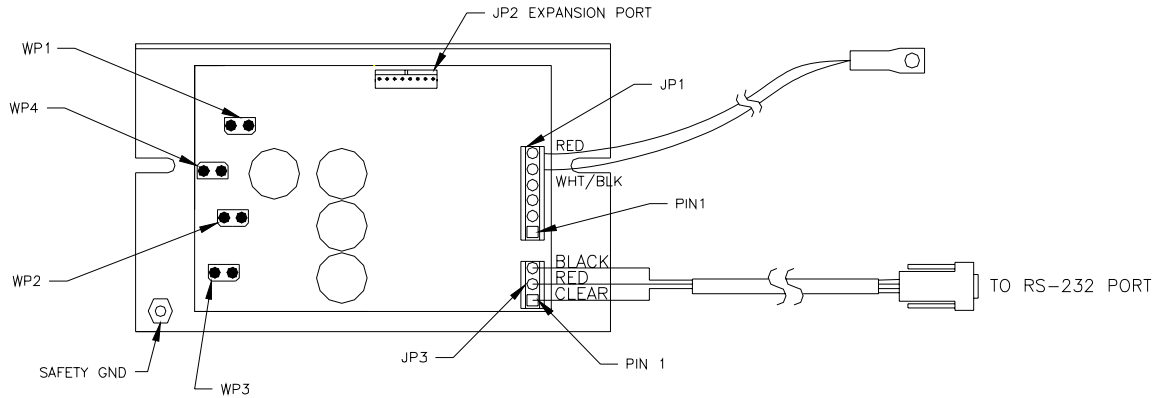

# Expansion Connector Wiring Diagram

Note: The 25 mA current source is a true current source. Maximum compliance voltage is approximately  $V+$ , the input voltage to the temperature controller. No external current limit resistors are needed for the LED. The LED must be capable of being driven with a 25 mA continuous current.

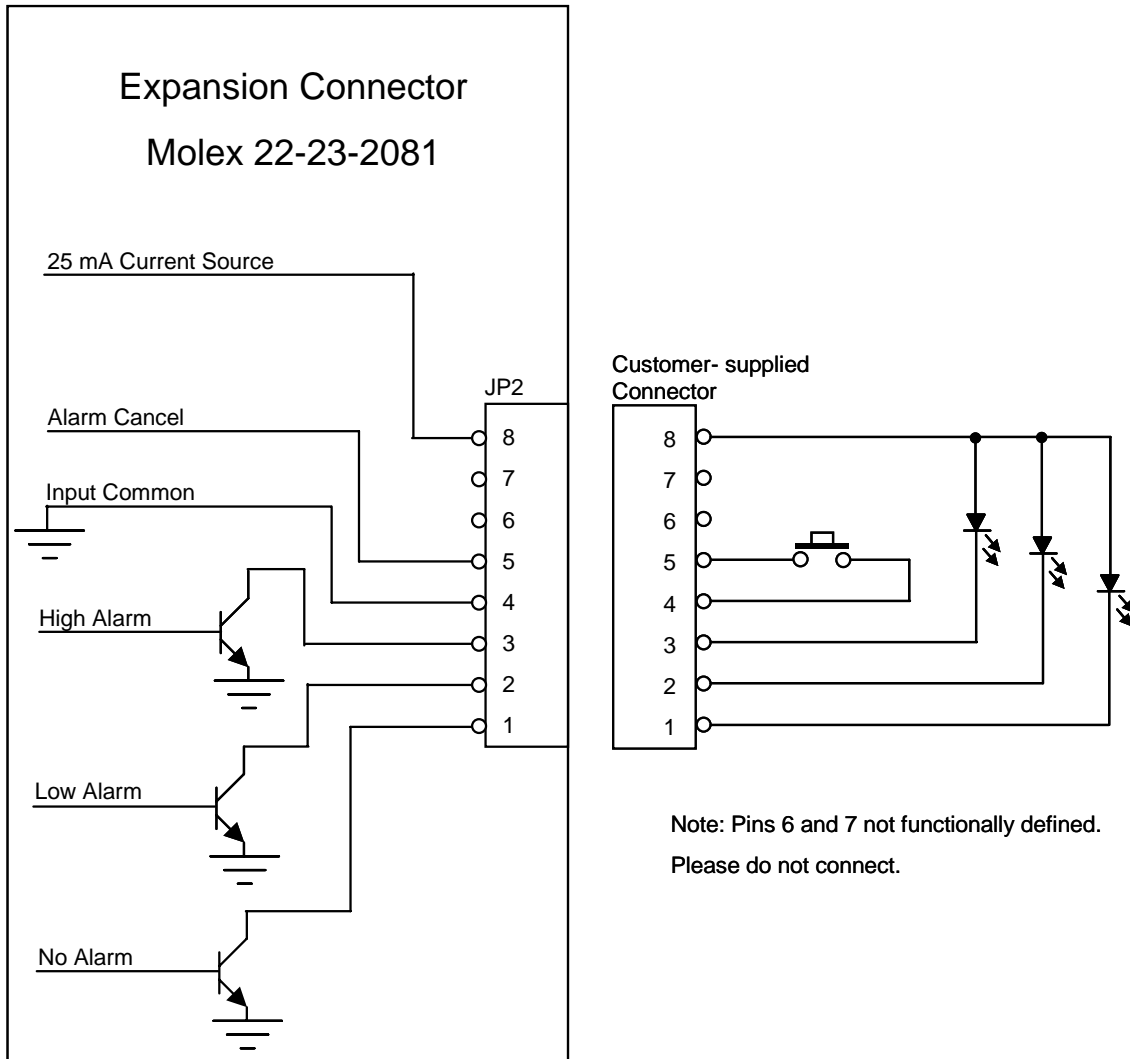

# Mechanical Package Drawing

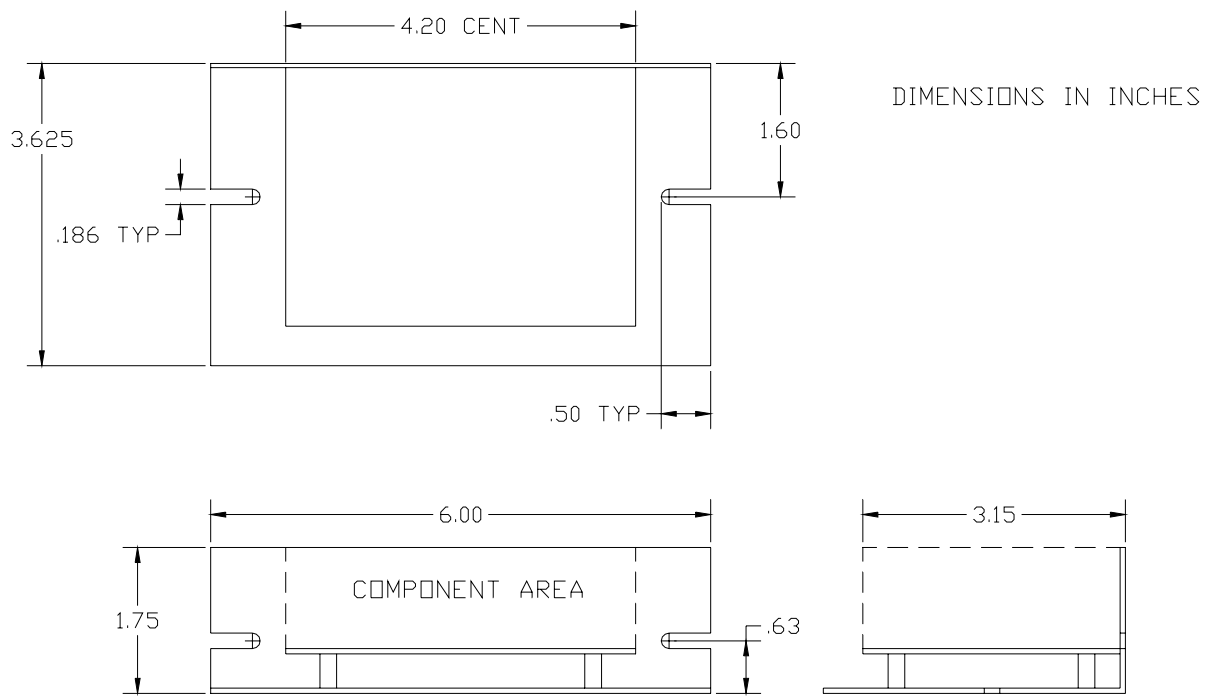

# Block Diagram

## INPUT #1 SENSOR

TEMPERATURE  
SENSOR  
-20 °C TO 100 °C

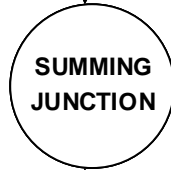

## CONTROL

PID  
PID W/ ALARM  
DEADBAND  
DEADBAND W/ ALARM

## OUTPUTS

H-BRIDGE  
1 TO 25 A PWM  
675 OR 2700 Hz

REMOTE INDICATOR  
RED/YELLOW/GREEN  
LED'S

## INPUT #2 AUXILLARY INPUT

10K OHM POTENTIOMETER  
0 TO 5 VDC\*  
4 to 20 mA DC\*\*  
OR  
0 TO 20 mA DC\*\*  
PC SET VALUE  
DIFF SET = INPUT 2

\*CONTROLLER INPUT IMPEDANCE 6.5K OHMS

\*\*REQUIRES ADDITION OF EXTERNAL RESISTOR

## RS232 Communications Connections

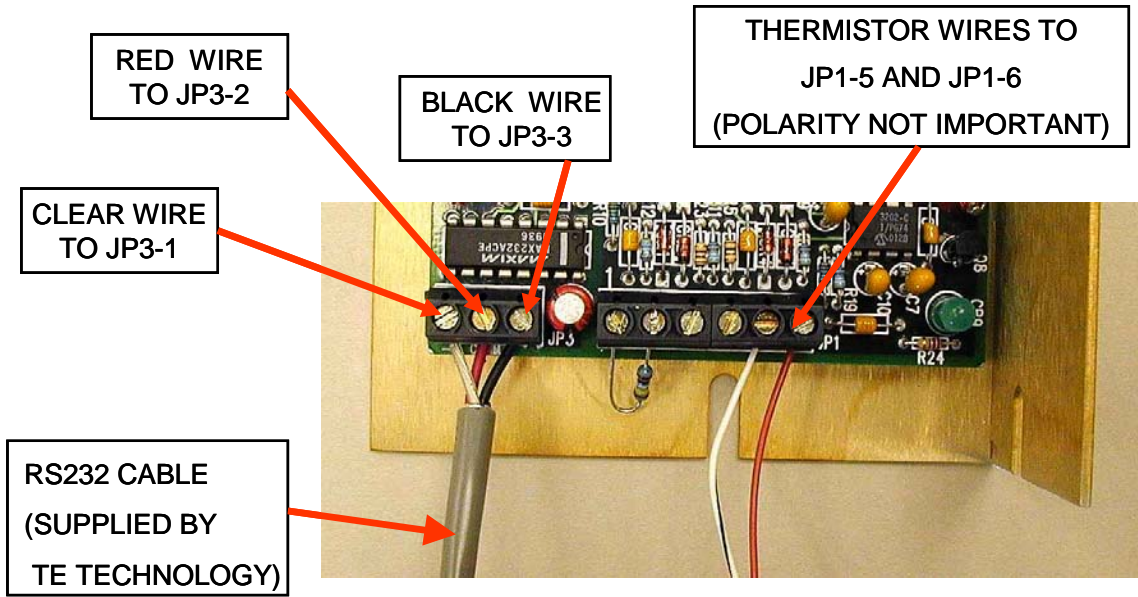

**PC CONNECTION TABLE**

PC CONNECTOR		PC FUNCTION*	CONTROLLER
9 PIN	25 PIN		
PIN 2	3	RECEIVE (RX)	TRANSMIT (TX) JP3-2
PIN 3	2	TRANSMIT (TX)	RECEIVE (RX) JP3-1
PIN 5	7	COMMON	SHIELD JP3-3

\*Functions normally assigned to pins.  
Check your PC manual to confirm



## APPENDIX A Troubleshooting Communications Port

You can perform a quick check of the comm. port (without having to initialize variables) by clicking the “CommCheck” button in the PC COMMUNICATIONS section of the software screen. You should have the controller connected to a comm. port and the controller powered up when performing the comm. check. A “COMM ERROR!” message will show if there is no hookup. If the connection is good a “COMM OKAY” message will appear.

When you initialize, an error message may show up if there is any additional problems. The following table offers possible solutions corresponding to a particular error:

Error Message	Cause	Solution
Comm Port Timeout	No power to TC-24-25 RS232 unit	Apply power to TC-24-25 RS232, review customer drawing for proper hookup.
Comm Port Timeout	Wrong Comm Port selected	Check computer hardware setting and set to the correct Comm Port.
Comm Port Timeout	Incorrect wiring of Comm Port to the computer.	Check for correct wiring from JP3 to the computer.
Comm Port Open Error	No Comm Port available at this port setting.	Check computer hardware setting and set to the correct Comm Port.

Note: See Appendix C, Section III RS232 Communications Parameters regarding the insertion of a delay between sending characters if you are using your own software program.

## APPENDIX B PID Tuning

Tuning the TC-24-25 temperature controller involves three variables: (P)ROPORTIONAL BANDWIDTH, (I)NTEGRAL GAIN, and (D)ERIVATIVE GAIN.

The control algorithm sums the three values of these terms to determine the output power.

**P + I + D = > Power Applied**

**Most applications work satisfactorily with only the “P” and “I” values used.**

Start the tuning process by setting the Integral and Derivative functions to zero. Then turn on the controller.

**PROPORTIONAL BANDWIDTH** is defined as the temperature range around the set point where the controller modulates (proportions) the output power. When the actual temperature deviates from the set temperature, the “P” term of the control equation is increased until the power output reaches 100%. Stated another way, the amount of temperature deviation required to increase the output to 100% is, by definition, the proportional bandwidth. The programmable bandwidth range of the TC-24-25 is from 1° to 100°. The units are shipped with a default setting of 20°.

Each thermal system has its own time constants determined by the thermal mass of the components and the placement of the sensor relative to the load. When the “I” and “D” terms are set to zero, and the bandwidth is too large, the temperature will never reach the set point. In this case the controller’s output will approach zero as the temperature difference approaches zero, so the system will never get the required power to actually reach the set point. On the other hand, if the bandwidth is too small and there is any time lag between the cooling/heating element and the temperature sensor, the temperature will initially overshoot the set point and then settle into a pattern of oscillation above and below the set point.

Assuming the controller is configured for your requirements, start the tuning process by applying power with the default settings and observing the system’s response. If the system comes into the proportional band and maintains a steady temperature near set point, without over shoot, the bandwidth setting is either satisfactory or too large. Reduce the bandwidth setting until the system just begins to oscillate. At this point, the bandwidth is too small. Note the bandwidth setting that just caused the system to oscillate, and record the period of oscillation for use in determining the Integral Gain setting. To set the proportional bandwidth, multiply the current bandwidth setting by 1.5 and use it as your new bandwidth setting. The system should come into control and maintain a steady temperature near the set point.

**INTEGRAL GAIN** monitors the difference between the set point and the actual temperature. Its function is to slowly change the output power until the difference between actual temperature and set temperature is zero.

The function works by integrating the error signal at fixed intervals. The intervals are expressed in repeats per minute. The acceptable range for the TC-24-25 is 0.01 to 10 repeats per minute. Start with a setting determined by the following formula:

Integral Gain =  $1/(2 \times T)$  where “T” is the period of oscillation measured above. The period is expressed in minutes.

Example: The system's period of oscillation with the appropriately set Proportional Bandwidth was 75 seconds. Therefore, the suggested Integral Gain is

$$\text{Integral Gain} = 1/(2 \times 1.25 \text{ minutes}) = 0.4 \text{ repeats/minute.}$$

For slower response but better stability, reduce the Integral Gain.

**DERIVATE GAIN** senses the rate of change of the temperature and allows the controller to anticipate the power needed to compensate for rapid changes in system loading. This term is generally used only on very sluggish systems or where very quick response is necessary. The acceptable range for the TC-24-25 is 0.1 to 10 cycles per minute.

To determine an appropriate derivate rate, use the following formula:

$$\text{Derivate Gain} = \text{Integral Gain}/10.$$

Continuing the above example, the Derivate Gain would be 0.04 cycles per minute.

*NOTE: DERIVATIVE GAIN is difficult to apply and often causes more trouble than it is worth. If you are not experienced in process control, you may be better off leaving the DERIVATIVE GAIN at zero.*

## APPENDIX C Serial Communications

### I. Definitions:

All numeric values are in hexadecimal format.

Use lowercase ASCII characters.

- (stx) Start of text character (\*) 2a hex.  
(etx) End of text character (carriage return) or 0d hex.  
(ack) Acknowledge character (^) 5e hex.
- AA Address characters are ASCII characters from 0 through 9 or a through f.  
**00 is the only address that should be used for the TC-24-25 RS-232.**
- CC Command characters are ASCII characters from 0 through 9 or a through f.
- DDDDDDDD Hex two's-complement return or send value.  
1d = 00000001  
-1d = ffffffff
- SS The 8-bit (modulo 256) checksum of characters sent to/from the controlling computer. This is represented as 2 ASCII hex characters. The checksum calculation excludes the characters (stx), SS, (etx). *The TC-24-25 RS232 sums (in an 8-bit register) the ASCII values of the characters sent to/from the controlling computer. Any overflow is truncated, leaving the 8-bit (modulo 256) checksum. When the controller is receiving data, this number (as represented by two hex characters) is compared to the two ASCII character hex checksum sent by the controlling computer. The TC-24-25 RS232 will respond as shown below depending on whether or not the checksums match. When the controlling computer is receiving data the checksum sent by the controller can be used to make sure the data has not been received with an error. Remember, when finding the ASCII value for a hex number (a, b, c, d, e, and f) be sure to use lower case letters.*

To write a command to a controller, the controlling computer must send the following ASCII characters:

(stx)AACCCDDDDDDSS(etx)

If the temperature controller receives the command and the checksum is correct, the temperature controller will respond by sending back the "send value" and the checksum of those eight ASCII characters:

(stx)DDDDDDSS(ack)

To query a controller, there is no send value so the controlling computer only needs to send the following ASCII characters:

(stx)AACCCSS(etx)

If the temperature controller receives the query and the checksum is correct, the temperature controller will respond by sending back a "return value" and the checksum of those eight ASCII characters:

(stx)DDDDDDSS(ack)

If the checksum for a command or query is not correct the temperature controller will respond with eight upper case X's and then c0, which is the checksum of these eight X's:

(stx)XXXXXXXXc0(ack)

Remember, AA = 00 is the universal address for the TC-24-25 RS232. If the address is not correct, then the controller will not respond to any requests.

## II. Examples:

Set the controller at address 00 to control via a computer programmable set point.

1. The controller address, AA, is by definition 00.
2. The control command, CC, for "INPUT2 DEFINE" is 29 hex.
3. A data value of "0" selects a computer communicated set value, so the eight-character send value DDDDDDDD is 00000000.
4. Compute the checksum (SS) by adding the ASCII values of the following characters: 0, 0, 2, 9, 0, 0, 0, 0, 0, 0, 0, 0, and 0:

<u>ASCII Character:</u>	<u>Hex Value:</u>
0	30 hex
0	30 hex
2	32 hex
9	39 hex
0	30 hex
0	30 hex
0	30 hex
0	30 hex
0	30 hex
0	30 hex
0	30 hex
0	30 hex
0	30 hex
<u>0</u>	<u>30 hex</u>
<b>Sum</b>	<b>024b hex</b>

The 8-bit checksum is the 8 least significant binary bits of the sum, represented as 4b in hex.

5. Combining all of these characters in one string we send: (stx)0029000000004b(etx).
6. If the temperature controller receives the command and the checksum is correct, it will send back: (stx)0000000080(ack). If the checksum is not correct the temperature controller will send back: (stx)XXXXXXXXc0(ack).

Send the set temperature of 100.0 °F to the controller at address 00.

1. The controller address, AA, is by definition 00.
2. The control command, CC, for “FIXED DESIRED CONTROL SETTING” is 1c.
3. Multiply the desired set-point temperature by 10 (100.0 converts 1000d).
4. Convert 1000d to hex (03e8h) and add on leading zeros to make the eight-character send value DDDDDDDD (000003e8).
5. Compute the checksum (SS) by adding the ASCII values of the following characters: 0, 0, 1, c, 0, 0, 0, 0, 3, e, and 8:

<u>ASCII Character:</u>	<u>Hex Value:</u>
0	30 hex
0	30 hex
1	31 hex
c	63 hex
0	30 hex
0	30 hex
0	30 hex
0	30 hex
0	30 hex
3	33 hex
e	65 hex
<u>8</u>	<u>38 hex</u>
<b>Sum</b>	<b>02b4 hex</b>

The 8-bit checksum is the 8 least significant binary bits of the sum, represented as b4 in hex.

6. Combining all of these characters in one string we send: (stx)001c000003e8b4(etx).
7. If the temperature controller receives the command and the checksum is correct, it will send back: (stx)000003e8c0(ack). If the checksum is not correct the temperature controller will send back: (stx)XXXXXXXXc0(ack).

Read the actual temperature of the control thermistor (INPUT1) from the controller at address 00.

1. Let us assume the actual temperature is 25.0 °C, and the working units have been defined as °C. This means that the controller will return a value in °C.
2. The controller address, AA, is by definition 00.
3. The control command, CC, for “INPUT1” is 01 hex.
4. There is no send value, so we can just calculate the checksum (SS) by adding the ASCII values of the following characters: 0, 0, 0, and 1:

<u>ASCII Character:</u>	<u>Hex Value:</u>
0	30 hex
0	30 hex
0	30 hex
<u>1</u>	<u>31 hex</u>
<b>Sum</b>	<b>00c1 hex</b>

The 8-bit checksum is the 8 least significant binary bits of the sum, represented as c1 in hex.

5. Combining all of these characters in one string we send: (stx)0001c1(etx).
6. If the temperature controller receives the command and the checksum is correct, it will send back: (stx)000000fae7(ack). The e7 at the end of the string is the checksum of “000000fa”. The value ”000000fa” hex converts to 250 in decimal. This number,

when divided by 10 is 25.0, is the temperature in °C. As in the other examples, if the checksum from the query were not correct the temperature controller would send back: (stx)XXXXXXXXc0(ack).

### III. RS232 Communications Parameters

- A. Baud Rate 9600
- B. No Parity
- C. 1 Start Bit 1 Stop Bit

***NOTE if you are using communications software different from the one supplied with the controller:*** The demands of temperature control require a relatively large portion of the processing power of the onboard microcontroller. It is possible for a host computer to send data too quickly for the controller to receive and update. TE Technology recommends adding a delay between each character sent to allow the controller sufficient time to process the information. One millisecond might be a good delay time to use initially, but the exact time will vary depending on the host computer's hardware and the particular demands on the controller at the moment.

### IV. Commands

1. INPUT1 (controlled input value)
  - Write Command: NA
  - Read Command: 01 hex
  - Interpret: Divide returned fixed-point temperature value by 10.0 and convert to °F/°C decimal value.  
Example:  
Receive 100.0 °F temp from unit (sensor type = 1).  
Send: \*00010000000042(etx)  
Receive \*000003e8c0^  
Convert hex 000003e8 returned to decimal = (1000)  
Divide by 10.0 = (100.0 °F)
2. DESIRED CONTROL VALUE (set value)
  - Write Command: NA
  - Read Command: 03 hex
  - Interpret: This command returns the set value determined by Input2 or as a fixed value set by communications (see #1 above for interpretation).
3. POWER OUTPUT
  - Write Command: NA
  - Read Command: 04 hex
  - Interpret: -255 represents -100% output.  
0 returned is 0% output.  
255 represents 100% output.
4. ALARM STATUS
  - Write Command: NA
  - Read Command: 05 hex

Interpret: 0 returned means no alarms.  
Bit 0 = 1 means HIGH ALARM.  
Bit 1 = 1 means LOW ALARM.  
Bit 2 = 1 means COMPUTER CONTROLLED ALARM.

5. INPUT 2

Write Command: NA  
Read Command: 06 hex  
Interpret: Input 2 reading as a thermistor temperature sensor.

6. ALARM TYPE

Write Command: 28 hex  
Read Command: 41 hex  
Interpret: 0 sent or returned means no alarms.  
1 sent or returned means Tracking Alarm Mode.  
2 sent or returned means Fixed Alarm Mode.  
3 sent or returned means Computer Controlled Alarm Mode (see write command 2f hex).

7. INPUT2 DEFINE (the desired control temperature or “set temp” input definition)

Write Command: 29 hex  
Read Command: 42 hex  
Interpret: This function tells the controller how the set-point temperature will be communicated.  
0 sent or returned means computer communicated set value.  
1 sent or returned means Potentiometer Input.  
2 sent or returned means 0 to 5 V Input.  
3 sent or returned means 0 to 20 mA Input.  
4 sent or returned means “Differential set”: Desired Control Value = Temp2 + Computer Set.  
Range of values settable via commands 20 hex & 21 hex (HIGH ALARM SETTING and LOW ALARM SETTING).

8. CONTROL TYPE

Write Command: 2b hex  
Read Command: 44 hex  
Interpret: 0 is deadband control.  
1 is PID control.  
2 is computer control. With this setting, the output power sent to the cooler is determined by sending a write command (0x1c) to INPUT1. The range of values then becomes -120 to +120, which corresponds to -100% output power to +100% output power.

9. CONTROL OUTPUT POLARITY

Write Command: 2c hex



Read Command: 45 hex  
Interpret: 0 is HEAT WP1+ and WP2-.  
1 is HEAT WP2+ and WP1-.

10. POWER ON/OFF

Write Command: 2d hex  
Read Command: 46 hex  
Interpret: 0 is off.  
1 is on.

11. OUTPUT SHUTDOWN IF ALARM

Write Command: 2e hex  
Read Command: 47 hex  
Interpret: 0 is no shutdown upon alarming.  
1 is to shutdown main output drive upon alarming.

12. FIXED DESIRED CONTROL SETTING

Write Command: 1c hex  
Read Command: 50 hex  
Interpret: When writing, multiply the desired control temperature by 10 and convert to hex. This becomes the “send value.”  
When reading, convert the “return value” to decimal and divide by 10.0 to convert to °F/°C.

13. PROPORTIONAL BANDWIDTH

Write Command: 1d hex  
Read Command: 51 hex  
Interpret: Fixed-point temperature bandwidth in °F/°C.  
Multiply desired bandwidth by 10.  
1 °F/°C bandwidth would be 10 decimal.  
100 °F/°C bandwidth would be 1000.

14. INTEGRAL GAIN

Write Command: 1e hex  
Read Command: 52 hex  
Interpret: Fixed-point gain in Repeats/min.  
Multiply desired integral gain by 100.  
0.01 rep/min would be 1 decimal.  
1.00 rep/min would be 100 decimal.

15. DERIVATIVE GAIN

Write Command: 1f hex  
Read Command: 53 hex  
Interpret: Fixed-point gain in minutes.  
Multiply desired derivative gain by 100.  
0.01 min would be 1 decimal.  
1.00 min would be 100 decimal.

16. LOW EXTERNAL SET RANGE

Write Command: 20 hex  
Read Command: 54 hex  
Interpret: Value mapped to zero voltage of Input2.

17. HIGH EXTERNAL SET RANGE

Write Command: 21 hex  
Read Command: 55 hex  
Interpret: Value mapped to 5 volt or maximum voltage of Input2.

18. ALARM DEADBAND

Write Command: 22 hex  
Read Command: 56 hex  
Interpret: Temperature Input1 must move to toggle alarm output.

19. HIGH ALARM SETTING

Write Command: 23 hex  
Read Command: 57 hex  
Interpret: Temperature reference to compare against Input1 for high alarm output.

20. LOW ALARM SETTING

Write Command: 24 hex  
Read Command: 58 hex  
Interpret: Temperature reference to compare against Input1 for low alarm output.

21. CONTROL DEADBAND SETTING

Write Command: 25 hex  
Read Command: 59 hex  
Interpret: Temperature or count span Input1 must move to toggle control output.

22. INPUT1 OFFSET

Write Command: 26 hex  
Read Command: 5a hex  
Interpret: Value to offset Input1 by in order to calibrate external sensor if desired.

23. INPUT2 OFFSET

Write Command: 27 hex  
Read Command: 5b hex  
Interpret: Value to offset Input2 by in order to calibrate external sensor if desired.

24. ALARM LATCH ENABLE

Write Command: 2f hex  
Read Command: 48 hex  
Interpret: 1 is latching enabled.  
0 is latching disabled.  
If Alarm Type is equal to 3 then  
1 is Computer Alarm On.  
0 is Computer Alarm Off.

25. CONTROL TIMEBASE

Write Command: 30 hex  
Read Command: 49 hex  
Interpret: Setting of 0 is 675 Hz timebase.  
Setting of 1 is 2700 Hz timebase.

26. ALARM LATCH RESET

Write Command: 33 hex  
Read Command: NA  
Interpret: Send this command to reset the alarm latches.

27. HEAT MULTIPLIER

Write Command: 0c hex  
Read Command: 5c hex  
Interpret: This multiplies the heater percentage of power to offset its effectiveness.  
100 is a multiplier of 1.00  
1 is a multiplier of 0.01

28. CHOOSE SENSOR FOR ALARM FUNCTION

Write Command: 31 hex  
Read Command: 4a hex  
Interpret: 0 is for the Control Sensor Input.  
1 is for the Input2 Secondary Input.

29. CHOOSE °C or °F TEMPERATURE WORKING UNITS

Write Command: 32 hex  
Read Command: 4b hex  
Interpret: 0 is °F  
1 is °C

30. SENSOR TYPE

Write Command: 2a hex  
Read Command: 43 hex  
Interpret: 0 is TS141 -40 °C to +70 °C  
1 is TS67 -20 °C to +100 °C

### 31. EEPROM WRITE ENABLE

Write Command: 34 hex  
 Read Command: 4c hex  
 Interpret: 0 is disable EEPROM writes  
 1 is enable EEPROM writes

Note: This function is always stored to EEPROM. This feature is available for controllers whose EEPROM is revision D or later. (The EEPROM has a white sticker on it labeled “C74-114D” where the last letter indicates the revision level.)

Function Description: Upon a power-up or reset condition, the controller performs an initialization of all command variables that have write commands by transferring the last values stored in non-volatile memory (EEPROM) to appropriately referenced static RAM locations. This action is performed so that the controller can run faster (RAM is faster than ROM). When the “EEPROM WRITE ENABLE” is enabled, any changes in the run-time values of the command variables are also stored in EEPROM as well in RAM and thus will be recalled upon a power-up or reset condition. When the “EEPROM WRITE ENABLE” is disabled, run-time values are stored only in RAM. This setting gives you the ability to change run-time values without changing your desired power-up settings. This will also alleviate a possible problem since the maximum number of writes to an EEPROM location is 1,000,000.

## V. ASCII Reference Table

Dec	Oct	Hex	Binary	Description
000	000	00	00000000	^@ ^` NULL NUL null c-@ c-`
001	001	01	00000001	^A ^a SOH GTL c-A c-a start-of-heading
002	002	02	00000010	^B ^b STX c-B c-b start-of-text
003	003	03	00000011	^C ^c ETX c-C c-c end-of-text
004	004	04	00000100	^D ^d EOT SDC end-of-transmission c-D c-d ..._._
005	005	05	00000101	^E ^e ENQ PPC c-E c-e enquiry
006	006	06	00000110	^F ^f ACK c-F c-f acknowledge
007	007	07	00000111	^G ^g BELL BEL bell c-G c-g \a
008	010	08	00001000	^H ^h BS GET backspace c-H c-h \b
009	011	09	00001001	^I ^i TAB TCT HT tab c-I c-i \t
010	012	0A	00001010	^J ^j LF lf linefeed c-J c-j \n
011	013	0B	00001011	^K ^k VT vertical-tab c-K c-k \v
012	014	0C	00001100	^L ^l FF ff formfeed page \f c-L c-l
013	015	0D	00001101	^M ^m CR cr carriage-return c-M c-m \r
014	016	0E	00001110	^N ^n SO c-N c-n shift-out
015	017	0F	00001111	^O ^o SI c-O c-o shift-in
016	020	10	00010000	^P ^p DLE c-P c-p data-link-escape
017	021	11	00010001	^Q ^q DC1 LLO go XON xon c-Q c-Q
018	022	12	00010010	^R ^r DC2 c-R c-r
019	023	13	00010011	^S ^s DC3 stop XOFF xoff c-S c-s
020	024	14	00010100	^T ^t DC4 DCL c-T c-t
021	025	15	00010101	^U ^u NAK PPU negative-acknowledge c-U c-u
022	026	16	00010110	^V ^v SYN c-V c-v synchronous-idle

023	027	17	00010111	^W ^w ETB end-of-transmission-block c-W c-w
024	030	18	00011000	^X ^x CAN SPE c-X c-x cancel
025	031	19	00011001	^Y ^y EM SPD c-Y c-y end-of-medium
026	032	1A	00011010	^Z ^z SUB suspend c-Z c-z substitute
027	033	1B	00011011	^[ ^{ ESC escape c-[ c-{ m-
028	034	1C	00011100	^\ ^  FS field-separator c-\ c-
029	035	1D	00011101	^] ^} GS group-separator
030	036	1E	00011110	^^ ^~ RS record-separator c-^ c--
031	037	1F	00011111	^_ ^DEL unit-separator US c-_ c-DEL
032	040	20	00100000	SPC space spc
033	041	21	00100001	! exclamation-point
034	042	22	00100010	" straight-double-quotation-mark
035	043	23	00100011	# number-sign
036	044	24	00100100	\$ @@ dollar-sign
037	045	25	00100101	% percent-sign
038	046	26	00100110	& ampersand
039	047	27	00100111	' apostrophe
040	050	28	00101000	( left-parenthesis
041	051	29	00101001	) right-parenthesis
042	052	2A	00101010	* asterisk star
043	053	2B	00101011	+ addition-sign
044	054	2C	00101100	, comma
045	055	2D	00101101	- subtraction-sign minus hyphen negative dash
046	056	2E	00101110	. period dot decimal
047	057	2F	00101111	/ right-slash
048	060	30	00110000	0
049	061	31	00110001	1
050	062	32	00110010	2
051	063	33	00110011	3
052	064	34	00110100	4
053	065	35	00110101	5
054	066	36	00110110	6
055	067	37	00110111	7
056	070	38	00111000	8
057	071	39	00111001	9
058	072	3A	00111010	: colon
059	073	3B	00111011	; semicolon
060	074	3C	00111100	< less-than
061	075	3D	00111101	= equals
062	076	3E	00111110	> greater-than, right-chevron
063	077	3F	00111111	? question-mark, query
064	100	40	01000000	@ at-symbol, at-sign
065	101	41	01000001	A
066	102	42	01000010	B
067	103	43	01000011	C
068	104	44	01000100	D
069	105	45	01000101	E
070	106	46	01000110	F
071	107	47	01000111	G
072	110	48	01001000	H
073	111	49	01001001	I
074	112	4A	01001010	J
075	113	4B	01001011	K
076	114	4C	01001100	L
077	115	4D	01001101	M
078	116	4E	01001110	N
079	117	4F	01001111	O

080	120	50	01010000	P
081	121	51	01010001	Q
082	122	52	01010010	R
083	123	53	01010011	S
084	124	54	01010100	T
085	125	55	01010101	U
086	126	56	01010110	V
087	127	57	01010111	W
088	130	58	01011000	X
089	131	59	01011001	Y
090	132	5A	01011010	Z
091	133	5B	01011011	[ left-bracket, open-square
092	134	5C	01011100	\ left-slash, backslash bash
093	135	5D	01011101	] right-bracket, close-square
094	136	5E	01011110	^ hat, circumflex, caret, up-arrow
095	137	5F	01011111	_ UNT, underscore, underbar
096	140	60	01100000	` accent-grave, backprime, backquote
097	141	61	01100001	a
098	142	62	01100010	b
099	143	63	01100011	c
100	144	64	01100100	d
101	145	65	01100101	e
102	146	66	01100110	f
103	147	67	01100111	g
104	150	68	01101000	h
105	151	69	01101001	i
106	152	6A	01101010	j
107	153	6B	01101011	k
108	154	6C	01101100	l
109	155	6D	01101101	m
110	156	6E	01101110	n
111	157	6F	01101111	o
112	160	70	01110000	p
113	161	71	01110001	q
114	162	72	01110010	r
115	163	73	01110011	s
116	164	74	01110100	t
117	165	75	01110101	u
118	166	76	01110110	v
119	167	77	01110111	w
120	170	78	01111000	x
121	171	79	01111001	y
122	172	7A	01111010	z
123	173	7B	01111011	{ left-brace begin
124	174	7C	01111100	logical-or vertical-bar
125	175	7D	01111101	} right-brace end
126	176	7E	01111110	~ similar
127	177	7F	01111111	^? DEL rubout delete

# APPENDIX D Thermistor Styles for TC-24-25 RS232

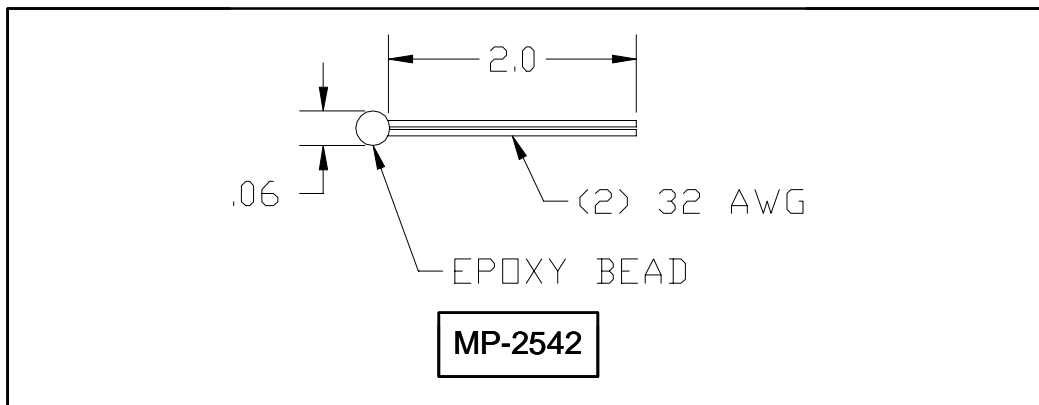
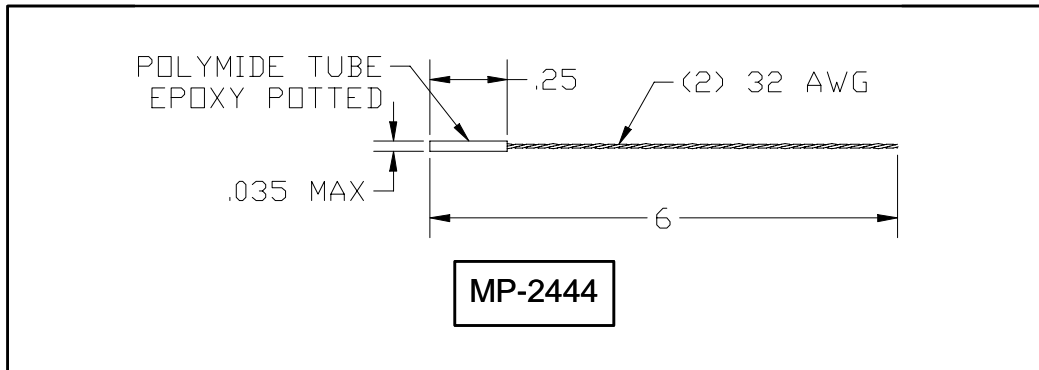
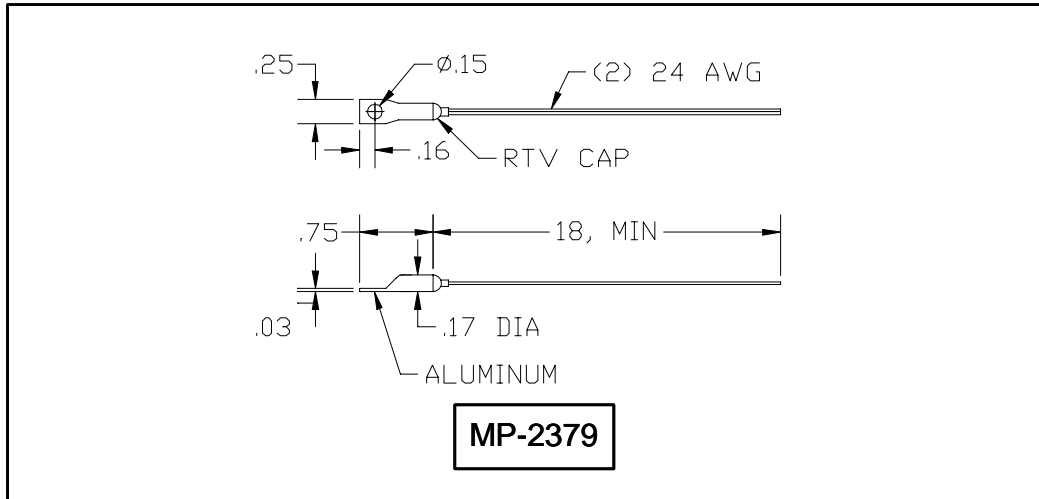



**Temperature (°C) versus Resistance (ohms)  
for MP-2379, MP-2444, and MP2542 Thermistors**

-20	146735	1	46709	22	17136	43	7075	64	3227	85	1601
-19	138447	2	44397	23	16388	44	6801	65	3115	86	1551
-18	130677	3	42213	24	15676	45	6539	66	3008	87	1503
-17	123390	4	40150	25	15000	46	6289	67	2905	88	1457
-16	116554	5	38199	26	14356	47	6049	68	2806	89	1412
-15	110138	6	36354	27	13744	48	5820	69	2711	90	1369
-14	104113	7	34608	28	13161	49	5600	70	2620	91	1328
-13	98454	8	32957	29	12606	50	5391	71	2532	92	1288
-12	93137	9	31394	30	12078	51	5190	72	2448	93	1250
-11	88138	10	29914	31	11574	52	4997	73	2367	94	1212
-10	83438	11	28512	32	11095	53	4813	74	2288	95	1176
-9	79016	12	27183	33	10637	54	4637	75	2213	96	1142
-8	74855	13	25925	34	10202	55	4467	76	2141	97	1108
-7	70938	14	24731	35	9786	56	4305	77	2072	98	1076
-6	67249	15	23600	36	9389	57	4150	78	2005	99	1045
-5	63773	16	22526	37	9011	58	4001	79	1940	100	1014
-4	60498	17	21508	38	8650	59	3858	80	1878		
-3	57410	18	20541	39	8306	60	3721	81	1818		
-2	54498	19	19623	40	7976	61	3590	82	1761		
-1	51750	20	18751	41	7662	62	3464	83	1705		
0	49157	21	17923	42	7362	63	3343	84	1652		

Note: Tolerance is  $\pm 650 \Omega$ , corresponding to  $\pm 1^\circ \text{C}$   
over a  $0^\circ \text{C}$  to  $100^\circ \text{C}$  range.