

# LC-066SS Peltier-Thermoelectric Liquid Cooler



- A compact, high-density extruded heat sink and a four-pass heat exchanger provides good cooling capacity in a small size.
- The only wetted surface is 316 stainless steel tubing making the liquid exchanger compatible with a wide variety of fluids.
- Two 316 stainless steel Mixer Coils can be easily added into the liquid tubing to improve performance at low flow rates. Mixer Coils sold and installed separately.
- Useful for small-to-medium heat loads in medical products, laser diode coolers, laboratory instruments, gas-stream dehumidification, etc.
- Heat-sink fan can be PWM controlled to reduce fan noise in low heat load conditions.
- Threaded hole located in liquid exchanger provides for easy attachment of a temperature sensor.
- CE marked; RoHS compliant.

**TE** TECHNOLOGY, INC.®

Expert Engineering, Precision Manufacturing:  
*Quality Thermal Solutions Delivered*

<https://tetech.com/> • [cool@tetech.com](mailto:cool@tetech.com) • 231-929-3966 • 1590 Keane Drive • Traverse City, MI 49696

# LC-066SS Specifications

Thermoelectric (TE) Power (typical)<sup>1</sup> : 24 VDC at 4.4 A  
 Thermoelectric (TE) Power (maximum)<sup>2</sup> : 24 VDC at 5.5 A  
 External (ambient) Fan Power: 24 VDC at 0.21 A  
 External (ambient) Fan Noise: 43 dBA

NEMA Rating: NA  
 Weight (kg): 1.52

**⚠** Please review the [Thermoelectric Cooling Assembly \(TCA\) Instruction Manual](#) (or [manual in other languages](#)), [ordering information](#), and [FAQ's](#) for related technical information before purchasing or using this product.

Performance is based on unrestricted air flow to fan and from air-flow outlets and 1.6 L/min water flow rate through the liquid heat exchanger. Do not operate if the ambient, liquid, heat sink, or liquid heat exchanger temperatures exceed 70 °C. Do not operate at air temperatures below -20 °C. Do not freeze the liquid. Do not exceed 1034 kPa water pressure.

<sup>1</sup>Current, at steady state, is rated at +25 °C ambient, +25 °C inlet water, maximum heat removal. At 5 °C inlet, the typical steady-state current is 4.25 A.

<sup>2</sup>Current, at steady-state operation under-worst case conditions, is rated at -10 °C ambient, +70 °C inlet, maximum heat removal.

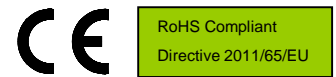

A 3D PDF, STEP, and Parasolid solid models are also available from the website.

All dimensions in millimeters.  
 Liquid heat exchanger side shown in blue;  
 External (ambient) side shown in red.

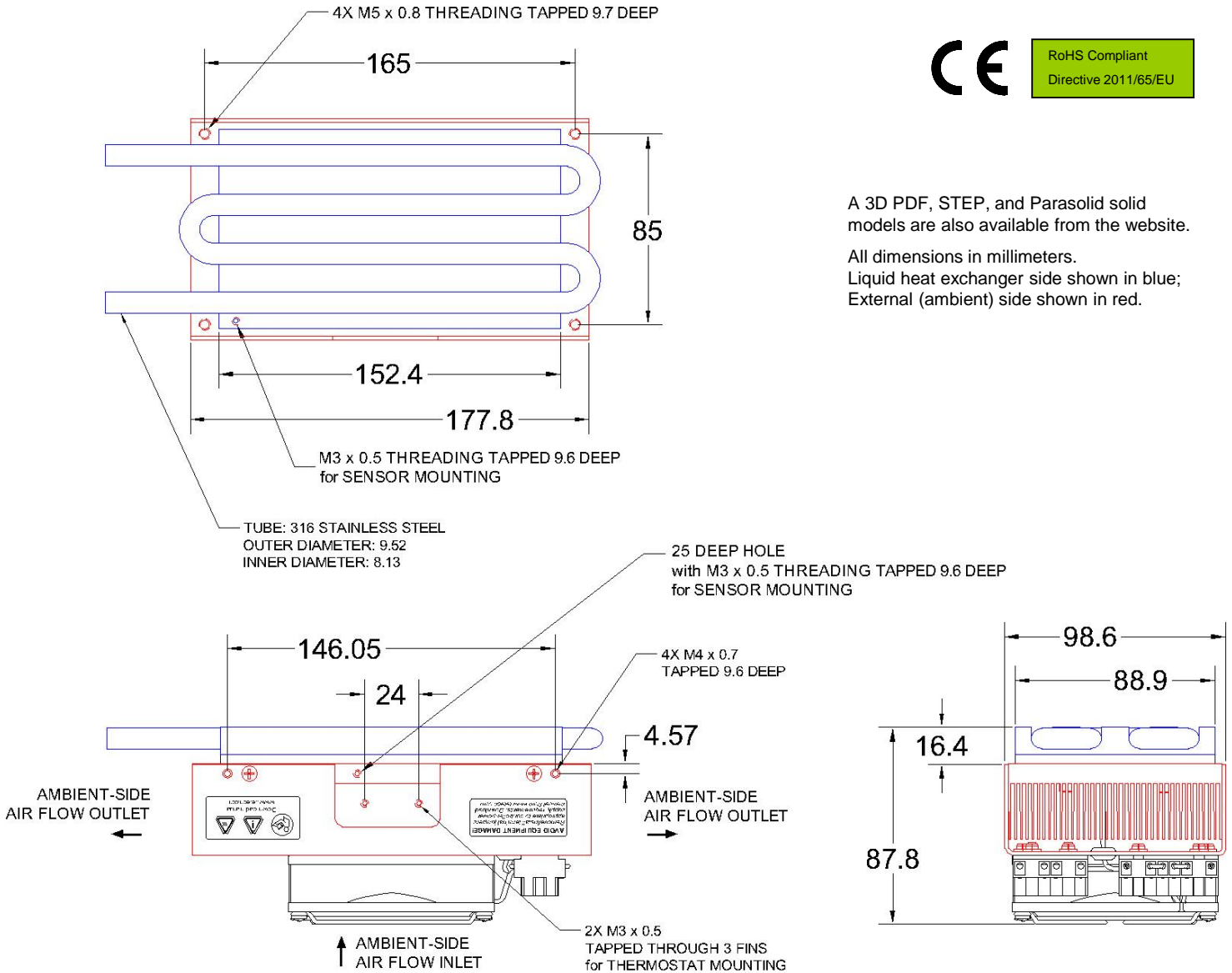

Expert Engineering, Precision Manufacturing:  
 Quality Thermal Solutions Delivered

<https://tetech.com/> • [cool@tetech.com](mailto:cool@tetech.com) • 231-929-3966 • 1590 Keane Drive • Traverse City, MI 49696

# LC-066SS Cooling Performance Graph

(removing heat from water, flowing at 1.6 L/min)

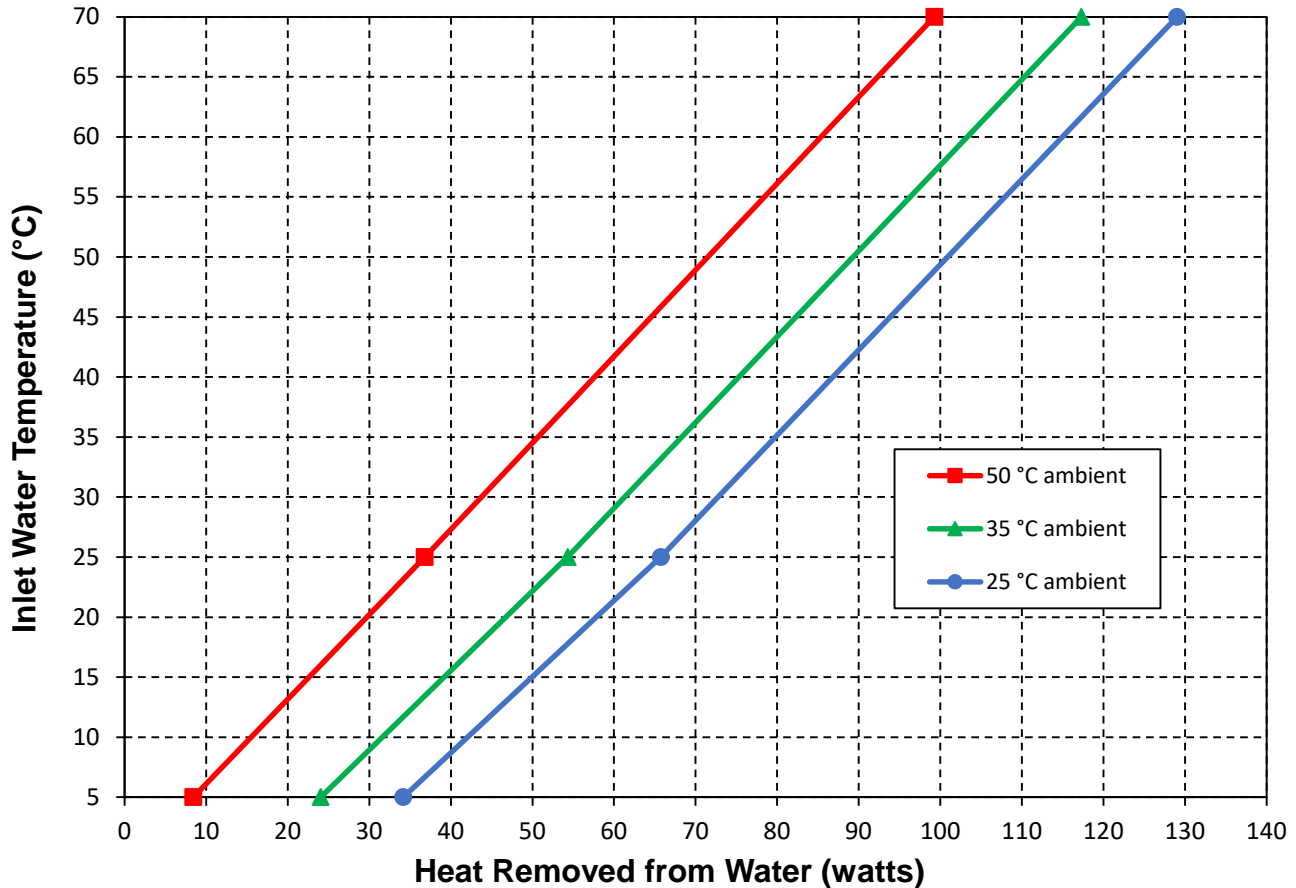

## How to use the Performance Graph:

### 1. Select Performance Line

The diagonal lines represent cooling performance at the indicated ambient air temperature (inlet temperature to the ambient-side heat sink). If the cooler is to operate at a different ambient, then you must sketch in a new performance line. This can be drawn parallel to one of the existing lines, using the distance between the existing lines as a scale to properly locate the new line.

### 2. Select Enclosure Temperature

Draw a horizontal line on the graph corresponding to the desired inlet water temperature until it intersects with the performance line corresponding to the ambient temperature at which the cooler is to operate.

### 3. Determine Cooling Capacity

The maximum amount of heat that the cooler can remove from the water is determined by the intersection point (determined in the previous step). *The cooler will be able to maintain the desired water temperature if the cooling capacity exceeds the heat load. If the heat load exceeds the cooling capacity then a higher capacity cooler will be needed.*

Example: You need to maintain the water at 15 °C while in a 25 °C ambient. The cooler can remove a maximum of approximately 50 W of heat from the water. If the heat load (internally generated heat plus the heat gain through insulation, solar, vapor condensation, etc.) in the system exceeds this, you would need more coolers and/or a larger cooler.

**TE** TECHNOLOGY, INC.®

Expert Engineering, Precision Manufacturing:  
*Quality Thermal Solutions Delivered*

<https://tetech.com/> • [cool@tetech.com](mailto:cool@tetech.com) • 231-929-3966 • 1590 Keane Drive • Traverse City, MI 49696

# LC-066SS Heating Performance Graph

(adding heat to water, flowing at 1.6 L/min)

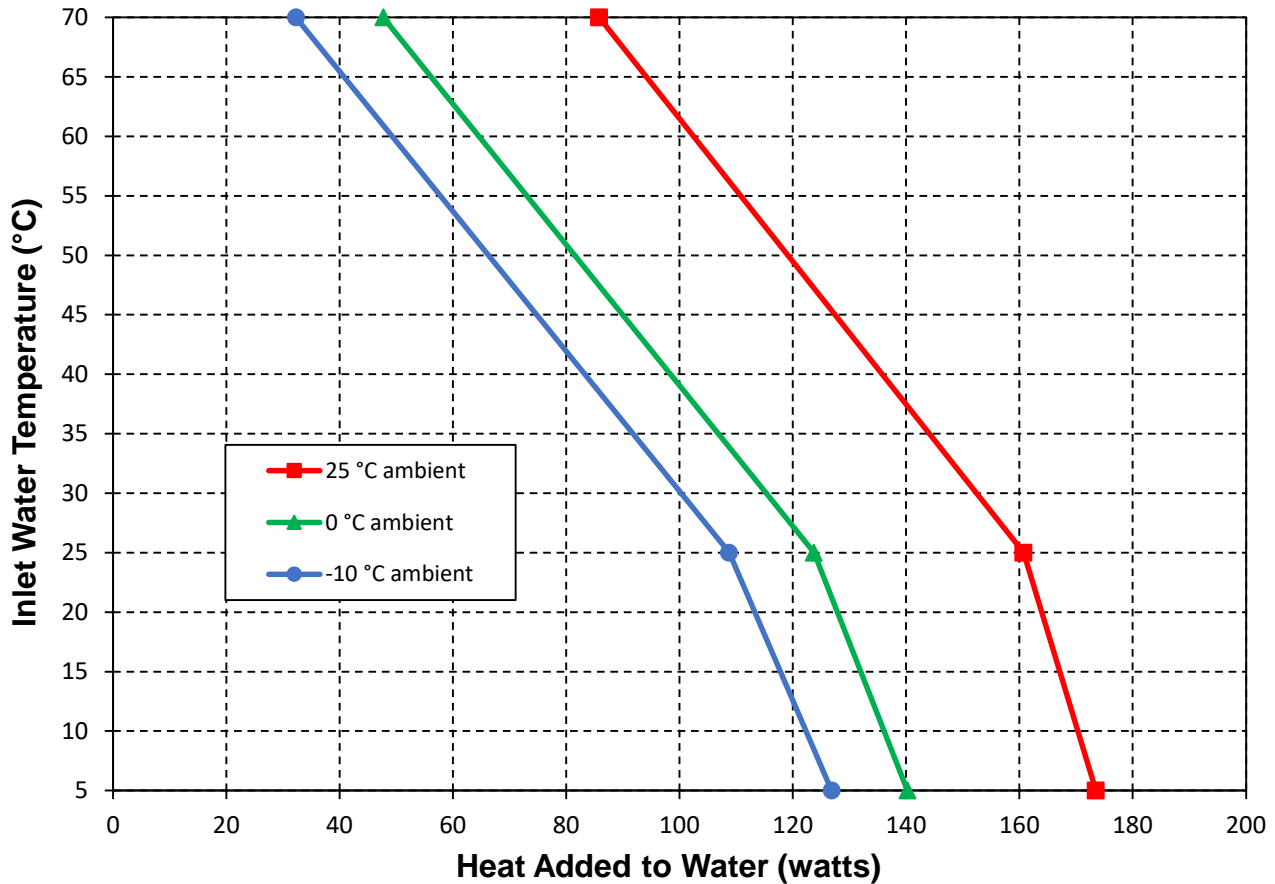

## How to use the Performance Graph:

### 1. Select Performance Line

The diagonal lines represent heating performance at the indicated ambient air temperature (inlet temperature to the ambient-side heat sink). If the cooler is to operate at a different ambient, then you must sketch in a new performance line. This can be drawn parallel to one of the existing lines, using the distance between the existing lines as a scale to properly locate the new line.

### 2. Select Enclosure Temperature

Draw a horizontal line on the graph corresponding to the desired inlet water temperature of the enclosure. Make the line intersect with the performance line corresponding to the ambient temperature at which the cooler is to operate.

### 3. Determine Heating Capacity

The maximum amount of heat that the cooler can add to the water is determined by the intersection point (determined in previous step). *If the heat added to the water (including heat generated by the system) is greater than the system's heat loss, then the cooler will be able to heat to the desired temperature. A higher capacity cooler will be needed if the total heat added is less than the system's heat loss.*

Example: You need to maintain the water at 30 °C while in a -10 °C ambient. The cooler can add a maximum of approximately 100 W of heat to the water. If the heat dissipation from the system exceeds this, you would need more coolers and/or a larger cooler.



Expert Engineering, Precision Manufacturing:  
Quality Thermal Solutions Delivered

<https://tetech.com/> • [cool@tetech.com](mailto:cool@tetech.com) • 231-929-3966 • 1590 Keane Drive • Traverse City, MI 49696



# LC-066SS with Two Mixer Coils Installed

(removing heat from water, flowing at 0.5 L/min; Mixer Coils sold separately)

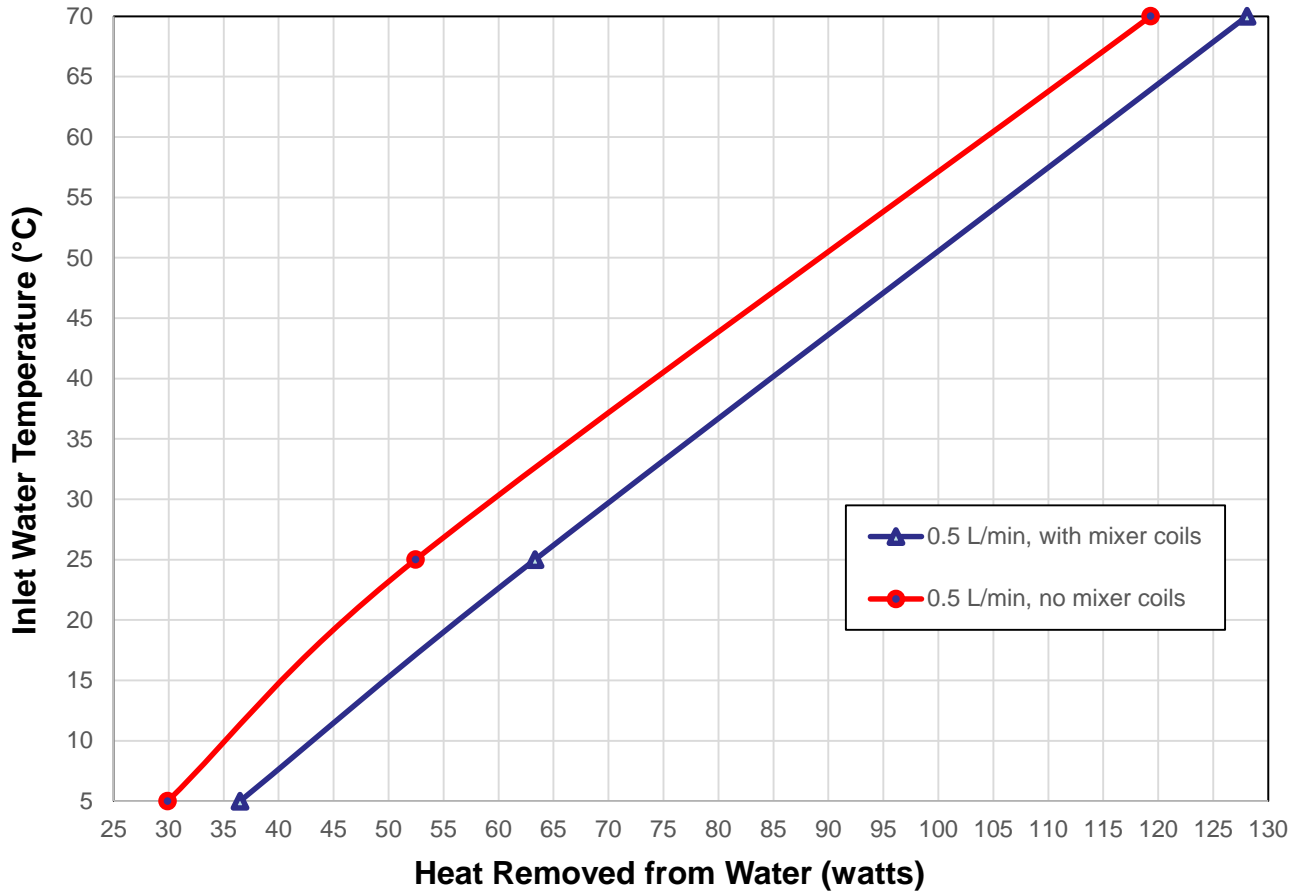

## How to use the Performance Graph:

### 1. Select Performance Line

The diagonal lines represent cooling performance at the indicated ambient air temperature (inlet temperature to the ambient-side heat sink). If the cooler is to operate at a different ambient, then you must sketch in a new performance line. This can be drawn parallel to one of the existing lines, using the distance between the existing lines as a scale to properly locate the new line.

### 2. Select Enclosure Temperature

Draw a horizontal line on the graph corresponding to the desired inlet water temperature until it intersects with the performance line corresponding to the ambient temperature at which the cooler is to operate.

### 3. Determine Cooling Capacity

The maximum amount of heat that the cooler can remove from the water is determined by the intersection point (determined in the previous step). *The cooler will be able to maintain the desired water temperature if the cooling capacity exceeds the heat load. If the heat load exceeds the cooling capacity then a higher capacity cooler will be needed.*

Example: You need to maintain the water at 15 °C while in a 25 °C ambient. The cooler can remove a maximum of approximately 54 W of heat from the water. If the heat load (internally generated heat plus the heat gain through insulation, solar, vapor condensation, etc.) in the system exceeds this, you would need more coolers and/or a larger cooler.

**TE** TECHNOLOGY, INC.®

Expert Engineering, Precision Manufacturing:  
*Quality Thermal Solutions Delivered*

<https://tetech.com/> • [cool@tetech.com](mailto:cool@tetech.com) • 231-929-3966 • 1590 Keane Drive • Traverse City, MI 49696

# LC-066SS External Fan Connections

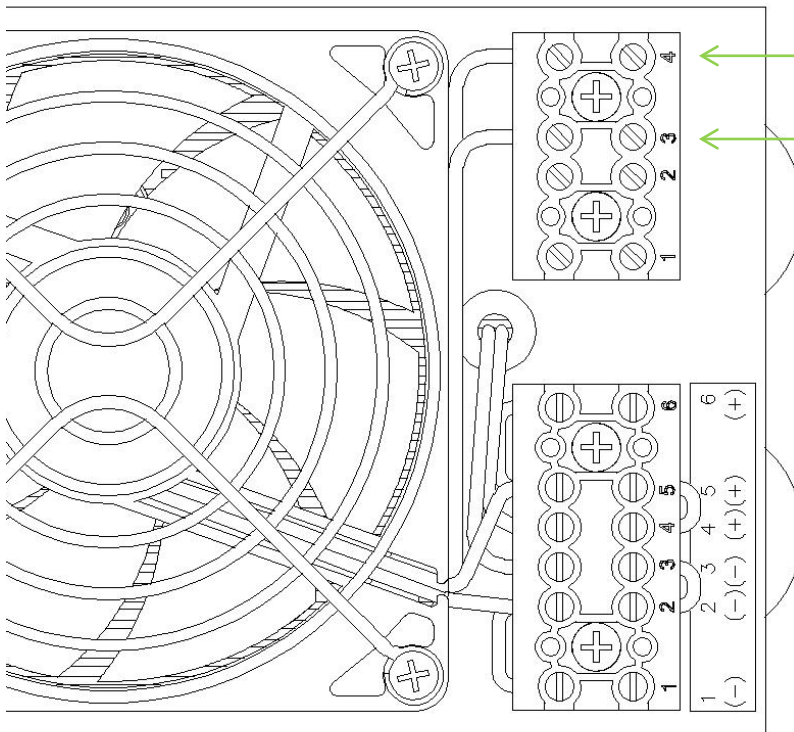
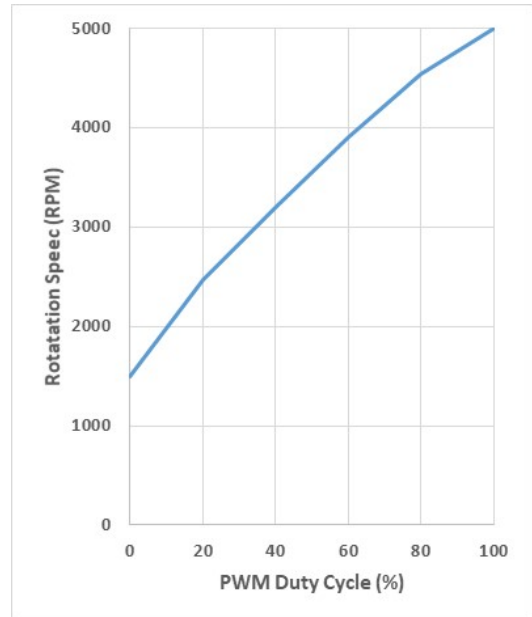
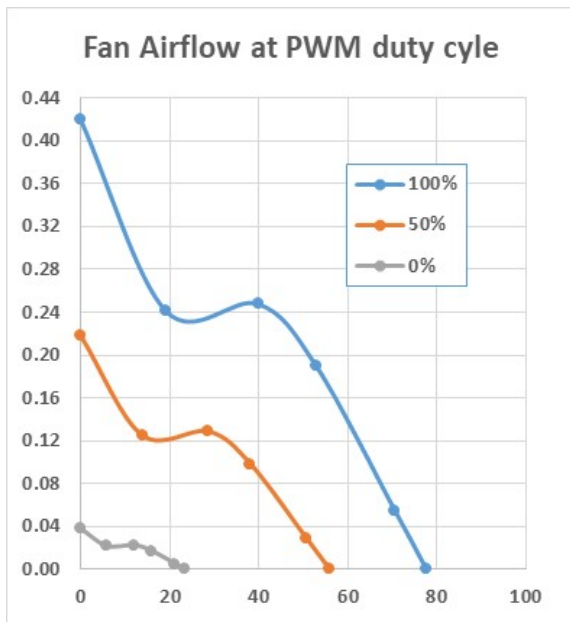

The external fan speed can be optionally controlled using pulse width modulation at a recommended 5 kHz to 25 kHz frequency applied at terminal position 4 (SPD CTRL, brown wire). The TC-720 temperature controller can be used to provide this PWM signal to reduce the audible noise at low cooling demands (use 5400Hz frequency setting). Electrical ground to terminal position 4 will reduce fan speed.

Terminal position 3 provides for a fan-speed sensor, sending two pulses per revolution. Consult with TE Technology if you wish to use this feature.

STRIP WIRE ENDS 7.6 mm (0.30 in), INSTALL WIRES (22-12 AWG), TIGHTEN SCREWS TO 0.56 N-m (5 lbs-in).



**NOTE:** Do not apply solder (tin) to the ends of the wires before inserting them into the connector. This will generate excessive heat at the terminal resulting in latent failures. Use copper wire only.

Do not allow heat sink temperature to exceed maximum limit when operating at low fan speeds.



Expert Engineering, Precision Manufacturing:  
*Quality Thermal Solutions Delivered*

<https://tetech.com/> • [cool@tetech.com](mailto:cool@tetech.com) • 231-929-3966 • 1590 Keane Drive • Traverse City, MI 49696

# Terminal Block Configuration for Continuous Operation at Full Power

## As-Shipped Configuration 1 of 2

1

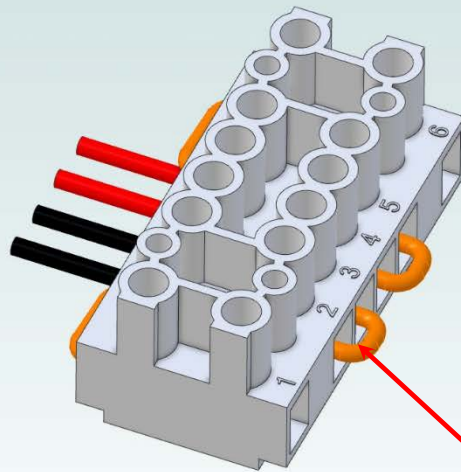

ELECTRICAL  
JUMPERS, SHOWN IN  
ORANGE, INSTALLED  
(ORIGINAL  
CONFIGURATION)

2

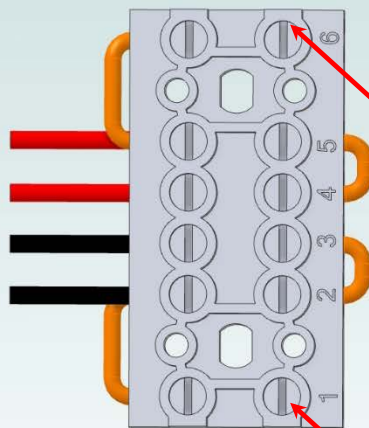

LOOSEN SCREW BUT  
DO NOT REMOVE

LOOSEN SCREW BUT  
DO NOT REMOVE

**TE** TECHNOLOGY, INC.®

Expert Engineering, Precision Manufacturing:  
*Quality Thermal Solutions Delivered*

<https://tetech.com/> • [cool@tetech.com](mailto:cool@tetech.com) • 231-929-3966 • 1590 Keane Drive • Traverse City, MI 49696

# Terminal Block Configuration for Continuous Operation at Full Power

## 2 of 2

3

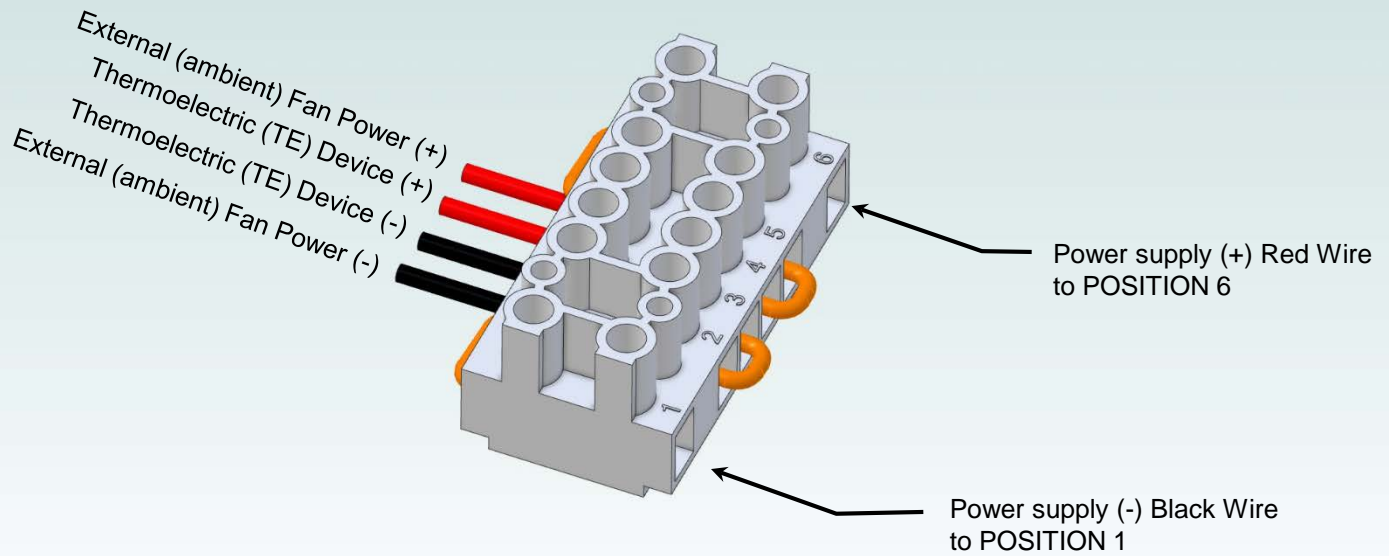

4

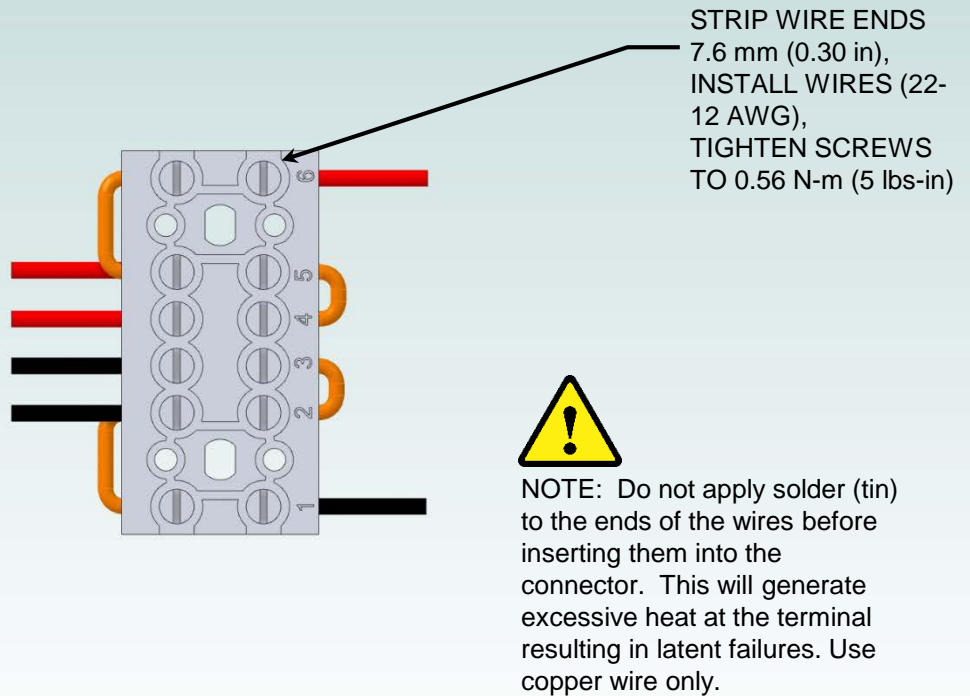

**TE** TECHNOLOGY, INC.®

Expert Engineering, Precision Manufacturing:  
*Quality Thermal Solutions Delivered*

<https://tetech.com/> • [cool@tetech.com](mailto:cool@tetech.com) • 231-929-3966 • 1590 Keane Drive • Traverse City, MI 49696



# Terminal Block Configuration for Operation with Temperature Controller

## 1 of 2

1

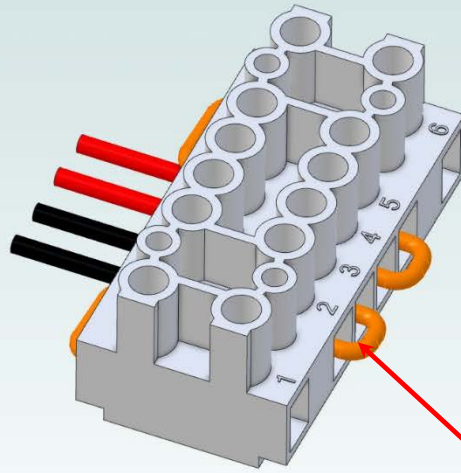

ELECTRICAL  
JUMPERS, SHOWN IN  
ORANGE, INSTALLED  
(ORIGINAL  
CONFIGURATION)

2

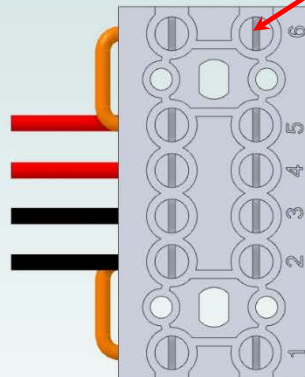

LOOSEN SCREWS  
BUT DO NOT  
REMOVE

REMOVE TWO  
ELECTRICAL JUMPERS  
FROM 2-3 AND 4-5

**TE** TECHNOLOGY, INC.®

Expert Engineering, Precision Manufacturing:  
*Quality Thermal Solutions Delivered*

<https://tetech.com/> • [cool@tetech.com](mailto:cool@tetech.com) • 231-929-3966 • 1590 Keane Drive • Traverse City, MI 49696

# Terminal Block Configuration for Operation with Temperature Controller

## 2 of 2

3

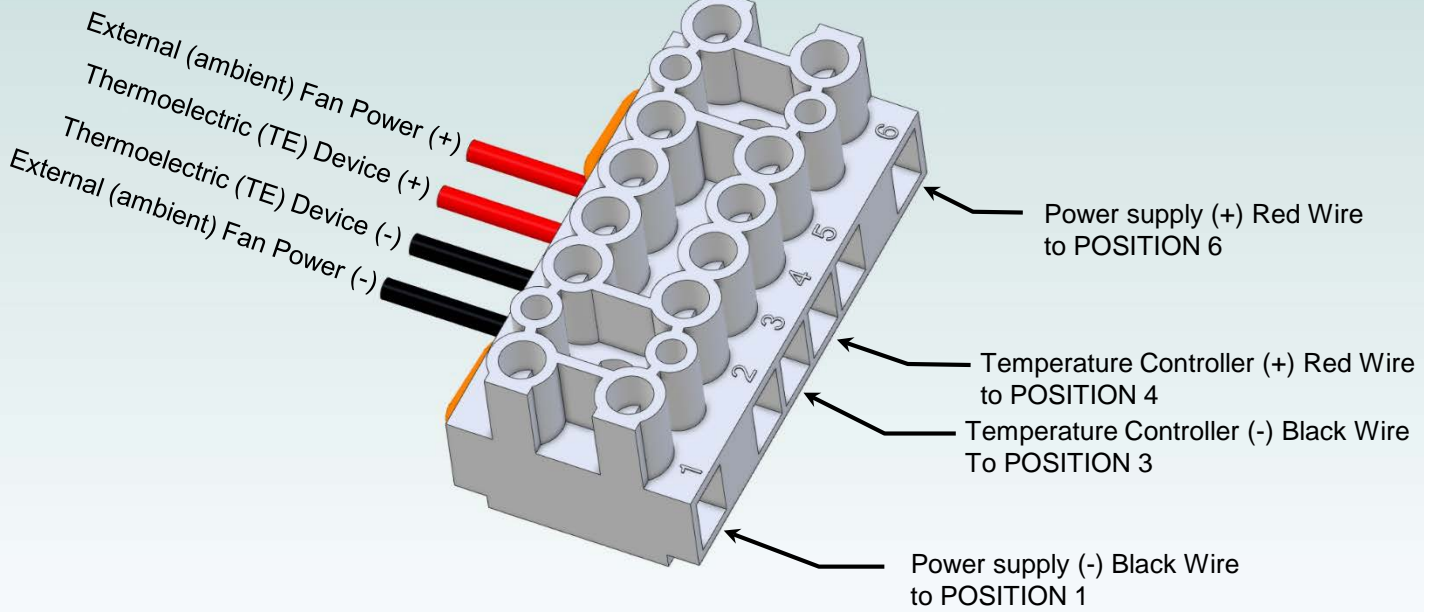

4

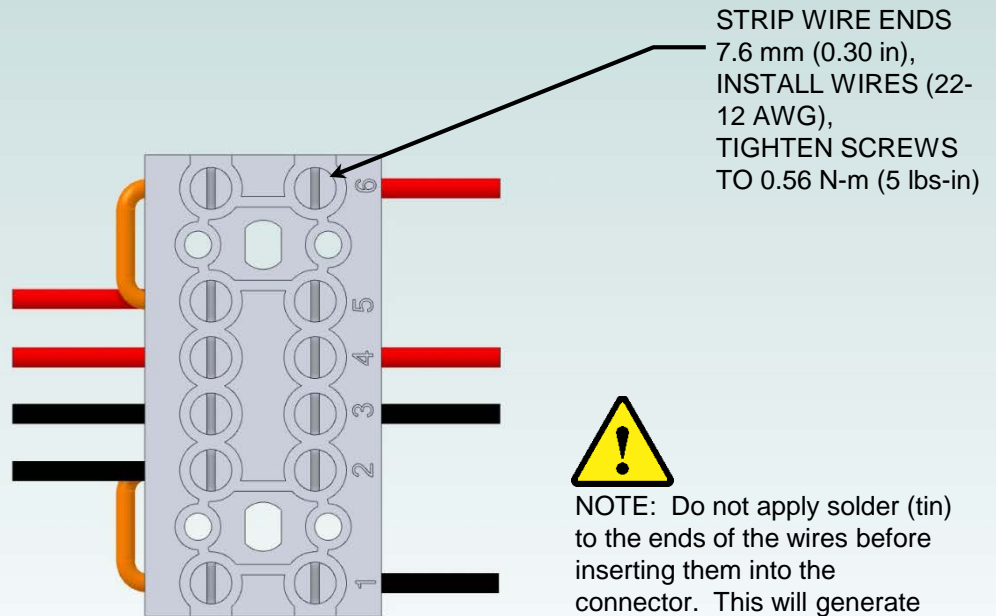

**TE** TECHNOLOGY, INC.®

Expert Engineering, Precision Manufacturing:  
*Quality Thermal Solutions Delivered*

<https://tetech.com/> • [cool@tetech.com](mailto:cool@tetech.com) • 231-929-3966 • 1590 Keane Drive • Traverse City, MI 49696